

## newsletter DEPARTMENT OF MATHEMATICS

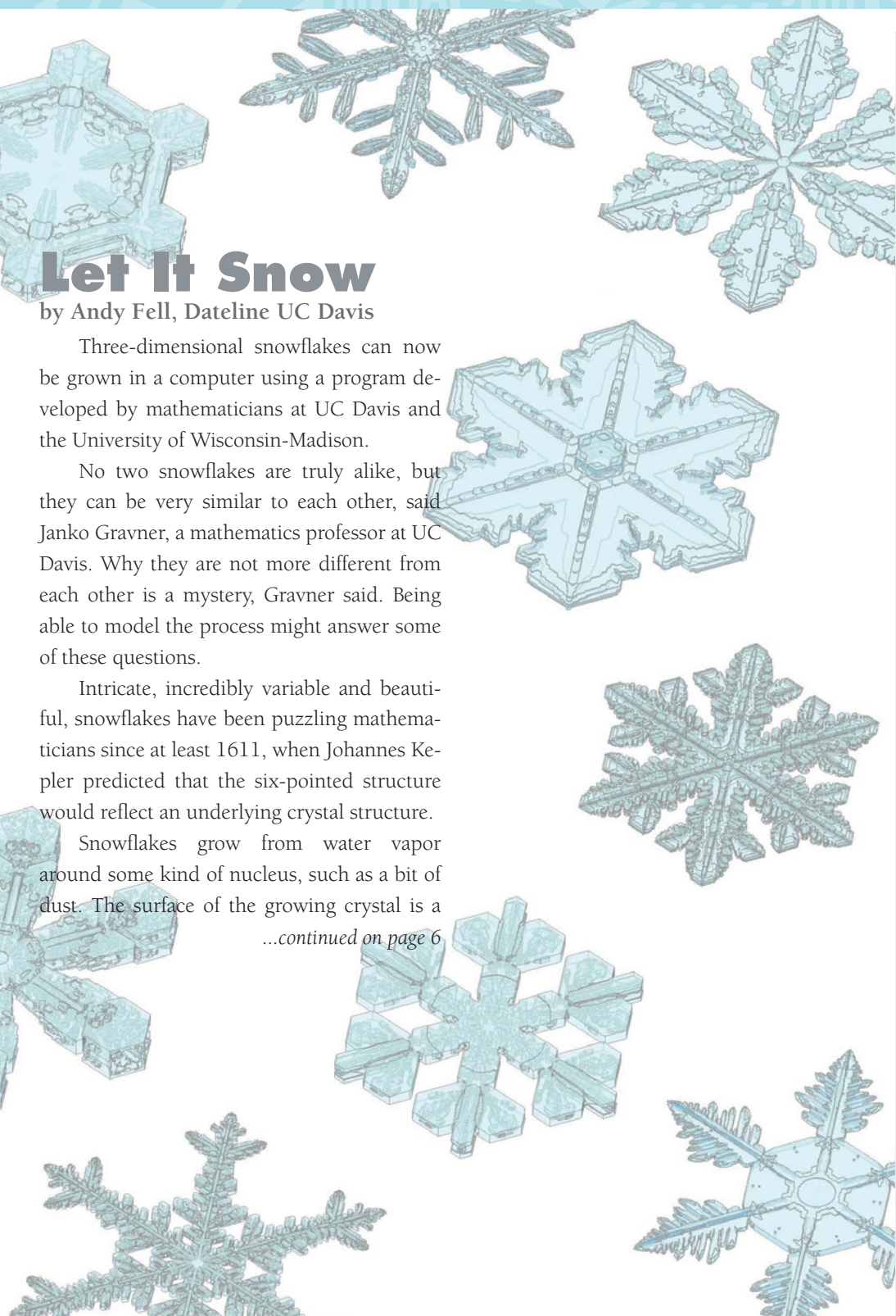

### Let It Snow

by Andy Fell, Dateline UC Davis

Three-dimensional snowflakes can now be grown in a computer using a program developed by mathematicians at UC Davis and the University of Wisconsin-Madison.

No two snowflakes are truly alike, but they can be very similar to each other, said Janko Gravner, a mathematics professor at UC Davis. Why they are not more different from each other is a mystery, Gravner said. Being able to model the process might answer some of these questions.

Intricate, incredibly variable and beautiful, snowflakes have been puzzling mathematicians since at least 1611, when Johannes Kepler predicted that the six-pointed structure would reflect an underlying crystal structure.

Snowflakes grow from water vapor around some kind of nucleus, such as a bit of dust. The surface of the growing crystal is a  
*...continued on page 6*

### contents

New Faculty & KAPs	2-3
New Postdocs	2-3
Snowflakes	1, 6
Letter from the Chair	6
Math Outreach	4-5
Undergraduate News	8
Graduate News	8-9
Awards	10-13
Life After Davis	7, 15
Emeriti News	14
Staff News	14



## Alessandro Pizzo

Alessandro Pizzo earned his Ph.D. from SISSA-Trieste, Italy in 2001. During his Ph.D. studies he worked on spectral and scattering problems in quantum field theory. Since then, he has been a postdoctoral researcher at several European institutes: the Departments of Mathematics at Mainz University, Germany, and University Paris XI, France; and the Institute of Theoretical Physics at ETH-Zürich, Switzerland. At ETH-Zürich he started a fruitful collaboration with Jürg Fröhlich, providing enlightening mathematical results in QED, ranging from spectral theory to renormalization schemes, expansion techniques, and scattering theory. His latest research activities include the mathematical analysis of random quantum systems.

## New Faculty



## Matthias Köppe

Matthias Köppe joins the UC Davis faculty as an Assistant Professor. He received his Ph.D. from the University of Magdeburg, Germany, in 2002, where he graduated with a thesis on primal methods in mathematical optimization under the direction of Robert Weismantel. In 2003, Matthias was awarded the dissertation prize of the German Operations Research Society.

After graduating, Matthias stayed at the University of Magdeburg, working as a researcher and lecturer. He visited the Center for Operations Research and Econometrics in Belgium in Spring 2004 on a postdoctoral fellowship.

In 2006, Matthias was awarded a Feodor Lynen Research Fellowship from the Alexander von Humboldt Foundation, to continue his collaboration with Jesús De Loera on rational generating function techniques in discrete optimization. Supported by this fellowship, Matthias visited our Department for three months in 2006 and six months in 2007.

In his research, Matthias is particularly interested in bringing new computational methods from algebra and geometry to practical use in solving optimization problems. At the same time, he looks for challenging new applications of mathematical optimization methods to problems in the sciences, engineering, and mathematics.

Matthias is excited to be part of the faculty at UC Davis. In their spare time, Matthias and his wife, Sabine, enjoy the great weather and the beautiful nature of Northern California.

He was awarded the Prize Annales Henri Poincaré 2003 for a novel technique introduced in his Ph.D. work. He will be plenary speaker at the International Congress on Mathematical Physics 2009 in Prague.

His research interests tie nicely with those of our mathematical physics and applied mathematics faculty. He now joins UC Davis as an Assistant Professor, and will be teaching a graduate Analysis course in Winter and Ordinary Differential Equations in Spring. He is looking forward to becoming part of our strong and active mathematical physics group.

Alessandro is excited about starting his new life in Davis. When not working, he relaxes with classical music, and he enjoys jogging, swimming, and playing soccer. As an “indoor sport,” he practices Mediterranean cooking.

## New Postdoc



## Jie Zhu

Jie Zhu received his Ph.D. in Physics from Washington University in St. Louis in May 2008. His research interest is biophysical modeling. His doctoral research focused on the growth dynamics and force generation of actin networks. He is now working with Professor Alex Mogilner on the motility of actin-driven biomimetic systems. In his spare time, Jie enjoys hiking and fishing.

# New Krener Assistant Professors



## David Widemann

David Widemann received his Ph.D. from the University of Maryland at College Park in May 2008 as a student of John Benedetto. His current interests are dimensionality reduction for high dimensional data and applied harmonic analysis. His work has been focused on compression for LIDAR data, dimensionality reduction for hyperspectral data, and analyzing microarray data. He is working with Professor Thomas Strohmer.

He enjoys going to the park with his wife and daughter and talking politics with friends.

## Alexander Coward

Alexander Coward has arrived in Davis having recently completed his doctorate at Oxford University. His main research interests lie in the area of 3-dimensional geometry and topology, and overlap with several existing members of faculty at UC Davis. His doctoral thesis was mainly concerned with building algorithms to answer topological questions about knots.

In his spare time, he enjoys swimming and music.



## Håkan Nordgren

Karl Håkan Nordgren received his Ph.D. from University of California, San Diego in June 2008. Confusingly, even though his first name is Karl, he likes to be known by his middle name, Håkan, which is pronounced ‘Hawk-an.’

Håkan’s mathematical interests lie in the neighborhood of analysis and mathematical physics. Indeed, his thesis was concerned with a free boundary problem for Euler’s equation for fluid flow, which was completed under the supervision of Hans Lindblad. At UC Davis, he will be working with Steve Shkoller.

He currently has three non-math interests:

His beautiful and talented girlfriend Amanda.

Politics, current events, foreign policy, economics. Håkan believes that there is no better entertainment than current events—and that current events are at their most entertaining when the U.S. is involved. Recent interests are the Middle East and Russia as well as macroeconomics and monetary policy. He reads the Financial Times and the Economist.

Exercise. He has recently re-discovered his love for swimming and is looking forward to checking out the Davis Aquatic Masters swimming as soon as he has finished moving into his apartment in Sacramento. He also lifts weights at the gym from time to time.

# New Postdoc



## Zhihua Zhang

Zhihua Zhang received his Ph.D. from UC Davis in 2007. His adviser was Prof. Naoki Saito. He has won the “Chinese Government Award for Outstanding Students Abroad,” and is now a postdoc at UC Davis.

Zhihua has published 23 papers in the field of wavelet analysis and its application, and derived a series of exciting and important results. His paper, “Supports of Fourier Transforms of Scaling Functions,” is the most downloaded paper in Applied and Computational Harmonic Analysis. Recently, he presented a method of particular solutions involving tangential derivatives to synthesize Laplacian eigenvalues/eigenfunctions and applied it to data classification and clustering. Now, he is working with Prof. Naoki Saito and Prof. Tony Tyson to introduce a method of repeated symmetry to deblend the galaxies using the Sloan Digital Sky Survey imaging data. This algorithm is expected to work very well on the future Large Synoptic Survey Telescope (LSST) imaging data.

He likes the climate of California and loves fat squirrels and wild ducks. In his leisure time, he likes to travel, drink tea, and watch TV.

# More to Explore

an update on the Explore Math program



Math Circle students respond to Prof. Biello's lecture



Math Circle exploring knot theory outdoors



Math Circle students attempting to unknot themselves

The Explore Math program begins its third full year of activities, continuing full steam ahead in bringing outreach to students of all ages. The campus recognized the organizers' recent successes, awarding the 2008 Community Service Award to both the Explore Math Program and the Math Modeling Experience subprogram.

The Math Modeling Experience (MME) is pleased to be kicking off another quarter with new undergraduate and high school participants. In addition to undergraduates from the Mathematics Department, 2008 MME students represent the Ecology, Physics, and Computer Science departments. High school students participating this year will come from schools as far west as Fairfield and as far north as Esparto.

MME research topics for 2008 will include disease transmission models, dynamic programming, facial imaging techniques, cell phone communication, and much more! The high school program once again culminated in an Open House poster session in November, as well as the HiMCM math modeling contest.

MME was pleased to have two high school teams ranked as Meritorious, and seven teams received honorable mention in the 2007 competition. Also, of three undergraduate teams that participated in the February 2008 MCM modeling contest, one was designated Meritorious and the other two teams were ranked Successful Participants. We look forward to another fun and successful season!

Math Circle enjoyed a very successful 2008 and is looking to continue introducing new generations of interested high school students to exciting mathematics. In Winter

2008, Math Circle attracted over 40 students from areas as far as 75 miles apart to travel here to the UC Davis Math Department and learn the mathematics behind such concepts as knot theory, fireflies and perspective drawings. The program ended with a day of Puzzle-mania in which the high school students participated in a contest composed of questions about the different subjects they learned in the program.

This year's Math Circle topics will be Probability and Games, Mathematical Graphics and Visualization, and Explorations in Hyperbolic Geometry, all of which will be taught by graduate students. We are looking forward to another successful year with hopes of reaching even more students at more schools.

Our American Regions Mathematics League team successfully competed in the ARML competition. In preparation, during Winter 2008, 30 high school students from as far away as El Dorado Hills learned about combinatorics and probability during intense weekly training sessions. During Spring quarter, a team of undergraduate participants helped sharpen the high school students problem-solving skills in preparation for the lightning-quick rounds of the national competition.

In May 2008, the students' hard work paid off as they and their graduate student coaches traveled to Las Vegas for the two-day competition. The UCD-trained team joined with a San Francisco Bay Area team and placed 21st nationally in the B division! We are planning for another successful year and hoping to place even higher this time.



The ARML team at the competition in Las Vegas



The ARML team posing after the competition

# Making Magic from Math

the second annual Math Fest

On July 23, 2008, UC Davis held its second annual Math Fest. This event, an outreach collaboration between the Mathematics Department and the COSMOS program, aims to demonstrate the fun side of mathematics. Its goal is to increase the popularity of mathematics among the public, in particular among young K-12 students. This year the main show was “Mathemagics: the art of mental calculation.” Our invited keynote speaker was Prof. Arthur Benjamin, from Harvey Mudd College. If anyone can convey the magical qualities of math and science, it is Prof. Benjamin—he leads a double life, both as a math professor, and as a professional magician. Prof. Benjamin holds a bachelor’s degree in applied mathematics from Carnegie-Mellon University and a Ph.D. in mathematical sciences from Johns Hopkins University. He has won awards for his teaching and writing. The COSMOS students were each given a copy of his book, “Secrets of Mental Math,” and he was designated “America’s Best Math Whiz.” As a professional magician, Prof. Benjamin has appeared on many television and radio programs. You can listen to an interview with him in NPR’s July 23rd archives for the radio program Insight at:

<http://www.cpradio.org/programs/insight/>

With over 400 students and their families attending, there was standing room only. The event kicked off with an amazing show by Prof. Benjamin. Starting with his “invisible card” trick that surprised us all, the show dashed into a quick sequence of astonishing math calculation tricks. Prof. Benjamin engaged the audience, who, calculators in hand, raced against him as people called out 3-digit numbers for him to multiply in his head. Every time, they verified Prof. Benjamin was correct, but could barely punch in the numbers before he sung out the answers. In fact he can multiply two 5-digit numbers while many hand calculators cannot (not enough digits!). Even better, he explained the mathematics behind his lightning-quick calculations and taught us all shortcuts and tricks for squaring large numbers in our heads. Later, he created “magic squares” (a  $4 \times 4$  grid whose sums along all rows, columns, and diagonals add to the same number) using the day, month,

and year of birth of select kids in the audience. Prof. Benjamin asked several audience members for their birthdays and told them on which day of the week they were born. He also explained his algorithm for these calculations. Much to the delight of the audience, and especially Prof. Benjamin, Hoby Wedler, a UCD student, was also able to determine the day of the week for birthdays by a completely different method.

During the question and answer session Prof. Benjamin talked about his life experiences and stated many times how mathematics is not only useful but also fun and beautiful, and urged students to not abandon their connection to mathematics. Indeed, one goal of our Math Department is to attract young people so they will consider pursuing a career in mathematics. It is clearly a great subject with fantastic career and job opportunities. For an hour after the show, audience members, students and parents alike crowded around Prof. Benjamin to ask him questions and even take photos and get autographs.

After this opening show, the public was treated to a wonderful selection of mathematical puzzles and games, as well as information about careers that use advanced mathematics (from the obvious ones like physics and engineering, to archeology and neurology). Kids and parents played mathematical games, constructed interesting polytopes and geometric surfaces, and wrestled with brain-teasers until darkness fell. The closing of the event was a showing of the films “Flatland” and “Shape of Space.” The first describes how aliens in a 2-dimensional universe discover there must be more dimensions (It is also an implicit commentary on how new ideas are not easily accepted by society). In the second movie we learn how mathematics, in particular topology, can predict the shape of our universe.

This event was sponsored by the National Science Foundation VIGRE grant and COSMOS (the California State Summer School for Mathematics & Science). Many thanks to all those who attended. A special thank you to the impressive turn-out of volunteers from faculty, staff, MAST, the graduate and undergraduate math students, and COSMOS.



Prof. Benjamin expounds on Mathemagics

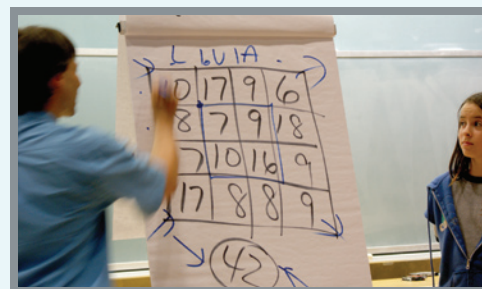

Prof. Benjamin explains “magic squares”



Grads explain the math behind bubbles



Students try to form specific shapes with limited blocks



A volunteer helps kids through a difficult puzzle

# The Dawn of a New Century

a letter from the Chair, Bruno Nachtergaele

UC Davis is celebrating a big birthday this year. Yes, a university celebrating its first centennial is an important event akin to a teenager's turning sixteen. It is customary to throw a big party and UC Davis is doing just that, all year long.

A university worthy of the name is a mini-universe of the mind. Much more than a mere collection of expert scholars and teachers, it is a community of intellectual exchange and growth, where much of the activity is centered on students. It has been said that today's economy is a knowledge economy. Today's society then is a society of learners. The generation and dissemination of knowledge is the bloodstream of our civilization, and the university is the heart of the knowledge system. UC Davis has attained a prominent position among the nation's universities as measured by a variety

of indices (scholarly productivity, research expenditures, societal relevance in the local and global context, etc.). This is what we are celebrating this year.

Not all the news is good news these days. The UC Davis Centennial is overshadowed by the global economic downturn. Remember, however, that the country's best guarantee to curb the negative trends of today is its educated workforce and a working democracy. There is always room for improvement in both these areas. The UC Davis Mathematics Department is committed to do its part.

We are always looking to expand options to financially support our talented students and innovative researchers. There are always more deserving (and often needy) students than available fellowships, more interesting projects in research and textbook develop-

ment than the Department can support.

One way to help celebrate UC Davis' sweet one hundred is to make a donation (see the donation page on our web site for ideas and options).

<http://www.math.ucdavis.edu/>  
And join the fun by attending some of the many events scheduled this year.

<http://centennial.ucdavis.edu/>  
With your support Davis will drive innovation for all of the next one hundred years.

## Let It Snow

*...continued from page 1*

complex, semi-liquid layer where water molecules from the surrounding vapor can attach or detach. Water molecules are more likely to attach at concavities in the crystal shape.

The model built by Gravner and David Griffeath of the University of Wisconsin-Madison takes these factors, as well as temperature, atmospheric pressure and water vapor density, into account. By running the model under different conditions, the researchers were able to recreate a wide range of natural snowflake shapes.

Rather than trying to model every water molecule, it divides the space into three-dimensional chunks one micrometer across. The program takes about 24 hours to produce one "snowflake" on a modern desktop computer.

As in the real world, needles are the most common pattern of computer-generated snowflake. The classic six-pointed "dendritic"

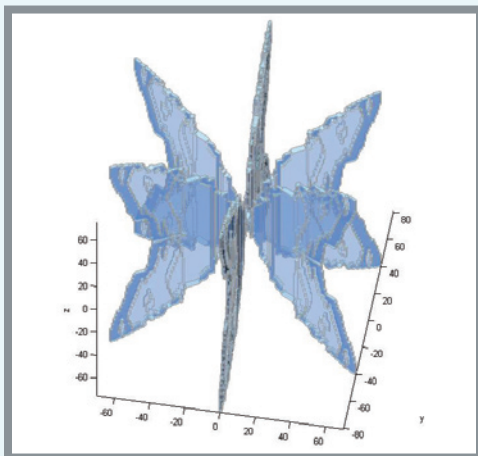

or feathery snowflake is relatively rare, both in the computer simulation and in nature.

Gravner and Griffeath also managed to generate some novel snowflakes, such as a "butterflake" that looks like three butterflies stuck together along the body. Gravner said there seemed to be no reason these shapes could not appear in nature, but they would be very fragile and unstable.

One surprise was that three-dimensional structure is often important, with complex structures often growing between two plates -- a feature that is difficult to see when observing actual snowflakes, but has been observed in careful studies of real snowflakes with electron microscopes.

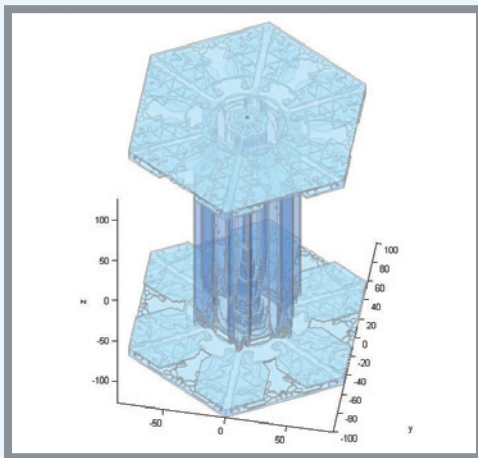

# Life After Davis

## Ruriko Yoshida

Ph.D. in Mathematics, 2004

If I were to give advice to graduate students, I would say two things: meet people and love what you do. Throughout my academic career, I have met many nice people and been very fortunate to meet them. Without their help, I would not have succeeded in my career. Here are three people who helped me and gave me great advice for the biggest decisions in my career.

First is my former adviser Prof. Jesús De Loera. After I graduated from UC Davis, I got a postdoc position at the Center for Pure and Applied Mathematics, UC Berkeley, under the direction of Prof. Lior Pachter. Then I went to the Mathematics Department at Duke University as a postdoc. In these two years at UC Berkeley and Duke I have been fascinated by applications of combinatorics to statistical problems in computational biology. When I was about to leave UC Davis, my adviser, Prof. Jesús De Loera, told me that I had to find “new research topics” in a new area during my postdoc term to expand my research areas. Back then I was not sure that I could find a new research topic and be specialized in the area but now I am glad that I took his advice.

The second person who helped me is my former mentor, Prof. Lior Pachter at UC Berkeley. When I started working with Prof. Pachter, I knew very little about computational biology. However, I was very fortunate that Prof. Pachter kindly taught me the very basics in statistics and computational biology. Even after I left UC Berkeley he has been giving me useful advice, and he has mentioned my name to many people in computational biology. We have written several papers together on the optimality of the neighbor-joining algorithm (with K. Eickmeyer, P. Huggins, and L. Pachter), *Algorithms for Molecular Biology*, Volume 3, Issue 5, (2008), and *Beyond Pairwise Distances: Neighbor Joining with Phylogenetic Diversity Estimates* (with Levy and Pachter), *Molecular Biology and Evolution*, (2006), 23(3) p491 - 498. It has been so much fun to work with him!



The third person, but not the least, is Prof. Bernd Sturmfels at UC Berkeley. Prof. Sturmfels has been always very kind and helpful. Whenever I have to make a big decision in my career, he has given to me very useful advice and offered me his help. For example, when I learned I got a position at Duke University Prof. Sturmfels took me to Duke with him and introduced me to many mathematicians at Duke and NCSU. Then when I moved to Duke, Prof. Sturmfels introduced me to Prof. Jeff Thorne at the Genomic Center in NCSU, from whom I have learned many concepts in computational biology. Even after I left UC Berkeley he invited me to write a chapter in the book “Algebraic Statistics in Computational Biology” edited by Prof. Pachter and Prof. Sturmfels. In late September 2005, Prof. Sturmfels suggested that I should apply for tenure-track positions in universities. Back then I did not even know that I could apply because I had one more year at Duke. Prof. Sturmfels helped me to apply for tenure-track positions not only by writing recommendation letters but also by introducing me to people at a conference at Clay Mathematics Institute. In fact, one of the people Prof. Sturmfels introduced to me was a statistician at University of Kentucky, Prof. Arne Bathke. Prof. Bathke told us that they had an open tenure-track bioinformatics position at the Statistics Department which I was offered and accepted.

I am very happy to be at the Statistics Department at the University of Kentucky. My colleagues, including the Department chair, Prof. Arny Stromberg, and a co-PI in my NIH grant, Prof. Chris Schardl, are very nice and very helpful to me. They are helping me succeed in my career, including my teaching. Thanks to their help, my NIH R01 grant has been funded over five years (Grant Number: 1R01GM086888-01 and the total award is \$1.4 million for five years). I am very fortunate that I have met great people in my career and that I love what I do for a living!

# Catching Up

**Steven T. Abell** (B.S. 1979) has had a variety of software development positions with several companies, mostly in and around Silicon Valley. His first job involved designing calculators for Hewlett-Packard, which was far-and-away the hardest work he has ever done. His favorite job was teaching the Smalltalk programming language to industrial classes. Currently he designs software at [brising.com](http://brising.com) in Fremont, California.

While he doesn't claim to be an active mathematician these days, he still buys math books, mostly about math history. He values the vantage point into many different subject areas that his math training provided.

Steven talks about his current favorite pastime:

“I've always enjoyed an audience (I was the 1979 L&S Commencement Speaker), and I did some stage acting for several years, just for fun. Then I moved into standup storytelling. I'm currently on the governing board of the Storytelling Association of Alta California, which is the organization behind the Bay Area Storytelling Festival. Also, I host an open storytelling group at a bookstore in Oakland.”

“A book of original stories I started off telling and eventually wrote down was published recently. ‘Days in Midgard’ is now available from the major online booksellers, or out of a box in the trunk of my car. It is based on Scandinavian mythology, another longstanding interest of mine. Whatever that description might bring to mind, these stories are probably different. One even requires the reader to do a (very) little math. All of them require a kind of reader involvement that will appeal to people who enjoy problems with not-quite-deterministic solutions.”



# News from the Undergraduate Program

by Andrew Waldron,  
Vice Chair for Undergraduate Matters

The Department awarded 66 undergraduate degrees this past academic year. Of those 66 students, two graduated with high honors and another four graduated with highest honors. Congratulations to all of our degree and award recipients.

The Department of Mathematics is continually striving to improve its undergraduate program. As a research department of the highest caliber and recipient of a renewed VIGRE grant we are able to offer undergraduates a mathematical education grounded in the latest mathematical advances as well as unique opportunities for undergraduate research.

In the past year, in addition to the ongoing evaluation of syllabi and textbooks, we carefully examined our undergraduate program through the five-year undergraduate program self-review and a calculus summit.

The self-review involved a large body of survey data of students and alumni provided by the 2006 UC Undergraduate Experience Survey. They found that math majors were uniformly very pleased with their degree experience and opportunities for careers and postgraduate studies.

The calculus summit was held in March and gathered together faculty and advisers from departments across campus whose students are served by our lower division courses. There were lively discussions on ways to improve student learning and outcomes. As a result, a joint committee of mathematicians and biologists have been working together to refashion the MAT 17 Calculus for Biology and Medicine syllabus. Our Partial Differential Equations courses are also being re-examined to create opportunities for engineers who need to study this fundamental area.

Once again, our mathematics majors excelled both at their coursework and research endeavours, and produced several very interesting undergraduate theses. Their accomplishments were celebrated at last June's Departmental Awards Ceremony.

# News from the Graduate Programs

by Thomas Strohmmer, Vice Chair for Graduate Matters  
and Naoki Saito, Chair of the Graduate Group in Applied Mathematics

Both our graduate programs keep growing. This Fall, we welcomed 18 new students, 11 in the GGAM Program and 7 in the Math Program. This is a distinguished group of students, including a recipient of a prestigious National Defense Science and Engineering Graduate Fellowship (Juliette Zerick), and a UCD Graduate Scholar Fellowship (Owen Lewis). The Math Program now has 70 students and 41 faculty members, while GGAM has 60 students and 80 faculty members.

For 2007-08, GGAM welcomed 11 new faculty members: Matt Bishop (CS); James Bremer (Math); Mark Goldman (Neurobiology, Physiology & Behavior); Robert Guy (Math); Thomas Harter (Land, Air, and Water Resources); Matthias Koeppe (Math); John Lagier (Bodega Marine Laboratory); Katherine Pollard (Statistics); James Sanchirico (Environmental Science and Policy); Sebastian Schreiber (Evolution and Ecology); and Becca Thomases (Math).

Our continuing students received numerous awards and honors, some of which are featured in this newsletter. In addition, Eva Strawbridge was awarded the MPS Dean's Graduate Student Prize in the College of Letters and Science. She, together with David Sivakoff (GGAM), Mohamed Omar (Math), and Rohit Thomas (Math) also received the Community Service Award. Furthermore, Deanna Needell has won the UC Davis Humanities Graduate Research Award again this year, her fourth time over four years.

For the academic year through Summer 2008, we granted 18 Ph.D.'s (10 Math, 8 GGAM), 17 M.A. degrees, 3 M.S. degrees, and 2 MAT degrees. A Ph.D. recipient, Brandy Wieggers (Angela Cheer's student), received the Chancellor's Achievement Award for Diversity and Community. Note that she was the third graduate student in our Department to be honored with this award (Momar Dieng (Math) and Yvonne Lai (Math) were previous recipients).

The third Annual GGAM Mini-Confer-

ence was held on January 12, 2008. According to conference coordinator Joseph Biello and GGAM Chair Naoki Saito, the conference manifests what GGAM is all about: a coming together of our students with faculty from across campus in order to facilitate fruitful collaborations. In an informal, day-long forum, 10 faculty members described their research interests, giving our students an opportunity to experience the many directions available to them in applied mathematics. The departments represented at the conference included Agricultural and Resource Economics, Applied Science, Computer Science, Electrical and Computer Engineering, Mechanical and Aeronautical Engineering, Mathematics, Neurobiology, and Physiology and Behavior. A record number of guests (59) attended the dinner at the Walter A. Buehler Alumni Center, which was another opportunity for faculty and students to get to know each other. The fourth Annual GGAM Mini-Conference is scheduled on January 10, 2009.

On May 2-3, 2008, the UC Davis SIAM Club held its first Annual Davis SIAM Student Research Conference. More than 50 conference attendees from UC Davis and CSU Sacramento saw over 20 presentations on applied topics ranging from atmospheric science to mathematical biology to plasma physics. Keynote speakers Professor Joe Keller of Stanford and Professor Raissa D'Souza of UC Davis (GGAM member) gave great talks on the mathematics of games and sports and graph/network theory. The conference was supported by SIAM and an NSF VIGRE mini-grant. More information on the UC Davis SIAM Club can be found at SIAM Club webpage:

<http://siam.math.ucdavis.edu/>



# 2007-08 Graduate Degree Recipients

- William Breslin**, Ph.D., Math : RTG Assistant Professor, Univ. of Michigan  
“Curvatures of Surfaces in Hyperbolic 3-Manifolds” under Hass
- Brendan Farrell**, Ph.D., Applied Math : Research Scientist, Technical Univ. of Berlin  
“Analysis of Noncommutative Operator Classes in Info. Theory & Harmonic Analysis” under Strohmer
- Eli Goldwyn**, Ph.D., Applied Math : Postdoc. Fellow, Univ. of Chicago  
“When Can Dispersal Synchronize Oscillating Populations?” under Hastings
- Raymond Guan**, Ph.D., Applied Math : Intern, Intel Corporation  
“Advanced Equalization Techniques for Wireless Communications” under Strohmer
- Andrew Hodge**, Ph.D., Math : Applied Research Mathematician, Dept. of Defense  
“The Degree of the Logarithmic Extension of the Contangent Bundle to the Moduli of Pointed Curves and Hitchin Systems, Spectral Curves and KP Equations” under Mulase
- Yvonne Lai**, Ph.D., Math : RTG Assistant Professor, Univ. of Michigan  
“An Effective Compactness Theorem for Coxeter Groups” under Kapovich
- Jaejeong Lee**, Ph.D., Math : J. Willard Gibbs Assistant Professor, Yale Univ.  
“Fundamental Domains of Convex Projective Structures” under Kapovich
- Dan Li**, Ph.D., Applied Math, Financial Modeling Analyst, Moody Wallstreet Analytics  
“Differential Expression Analysis for Proteomics Data by 2D Gel Electrophoresis” under Rocke
- Yung-Ta Li**, Ph.D., Applied Math : Postgrad. Researcher, National Chiao Tung Univ.  
“A Krylov Projection Method for Model Order Reduction of Parameterized Linear Dynamical Systems” under Bai
- Shuang Liu**, Ph.D., Applied Math : Senior Financial Mathematician, SLCG, Inc.  
“Improving the Classification of Microarray Data: Supervised & Unsupervised Methods” under Rocke
- Fabiola Manjarrez-Guiterrez**, Ph.D., Math : Lecturer, UC Davis, Mathematics  
“Thin Circle-valued Morse Functions for Knots in  $S^3$ ” under Thompson
- Spyridon Michalakis**, Ph.D., Applied Math : Research Assoc., Los Alamos Nat'l. Labs  
“Entanglement and Ground States of Gapped Hamiltonians” under Nachtergaele
- Kei Nakamura**, Ph.D., Math : Visiting Research Asst. Professor, Oklahoma State Univ.  
“Some Results in Topology and Group Theory” under Hass
- Daniel Rutherford**, Ph.D., Math : Assistant Research Professor, Duke Univ.  
“Relationships Between Legendrian Knot Invariants” under Fuchs
- Chan-Ho Suh**, Ph.D., Math : Fellow, Univ. of Victoria, Pacific Institute  
“Modified Normal Surface Theories” under Hass
- Brandy Wieggers**, Ph.D., Applied Math : Math Circle Coordinator, MSRI  
“A Model for Water Relations During Primary Plant Root Growth” under Cheer
- Michael Williams**, Ph.D., Math : Postdoctoral, UC Santa Barbara  
“Lens Space Surgeries on Tunnel Number One Knots” under Thompson
- Constance Wilmarth**, Ph.D., Math : Assistant Professor, Northwest Christian College  
“Projections of Singular Vectors of Verma Modules over Rank 2 Kac-Moody Lie Algebras” under Fuchs
- Roy Wright**, Ph.D., Applied Math : Visiting Asst. Research Prof., Truman State Univ.  
“Spatial and Temporal Heterogeneity of Host-Parasitoid Interactions in Lupine Habitat” under Hastings
- Pengchong “Mike” Yan**, Ph.D., Applied Math : von Karman Instructor, Calif. Inst. of Tech.  
“Broadband Detection and Imaging of Multiple Targets in Clutter” under Fannjiang
- Robert Gutierrez**, M.A., Math : Instructor, Reedley College
- Robert Gysel**, M.A., Math : Continuing Ph.D. in Computer Science at UC Davis
- Corrine Kirkbride**, M.A., Math : Instructor, Solano Community College
- Julianne Kopriva**, M.A., Math : Continuing as Credential Student in Education, UC Davis
- Shawn Lanier**, M.A., Math : Instructor, Pioneer High School
- Dustin Pluta**, M.A., Math
- Michelle Stutey**, M.A., Math
- Diana Webb**, M.A., Math : Instructor, Santiago Canyon College
- Yuting Yang**, M.A., Math : Pursuing Ph.D. in Mathematics, Univ. of Michigan
- Keyvan Hassan Alekasir**, M.S., Applied Math : Quantitative Equity Analyst, T. Rowe Price
- Mohamed Ebeida**, M.S., Applied Math : Postdoc. Fellow, Carnegie-Mellon Univ.
- Katy Marchand**, M.S., Applied Math : Educator, Woodland Christian High School
- Chengwu Shao**, M.S., Applied Math : Pursuing Ph.D. at Stanford Univ.

## Peerless Advice from the Peer Adviser

Allison O'Hair is very excited to be joining the Department of Mathematics as its Peer Adviser for the 2008-09 year. Entering her final year as an undergraduate mathematics major, she has much to offer after having experienced and completed many upper division mathematics courses including Modern Algebra, Real Analysis, Combinatorics, Topology, and Advanced Linear Algebra.

“There are many things I love about mathematics, including the wide range of applications and disciplines that it provides. In almost all of our daily activities, we are able to experience the beauty of mathematics. Without hesitation, I would definitely come to UC Davis again as an undergraduate. I have had an amazing experience here, including the classes I have taken, the friends I have met, and just being immersed in the overall environment.”

Throughout her undergraduate studies, Allison has made the most of the opportunities that have come her way. As a freshman, she participated in the Integrated Studies Honors Program where she enjoyed taking classes in other disciplines. She has also enjoyed participating in both the Math Modeling Experience and Math Circle programs in Explore Math. Most recently, she took part in a Research Experience for Undergraduates (REU), working alongside Math faculty and others in her cohort.

This year, she plans to continue taking math classes while also enrolling in some computer science courses. After graduation, Allison hopes to continue her education in graduate school.

When asked what she expects to gain from being the Department's Peer Adviser, she stated, “I am very excited to be the mathematics peer adviser, not only because I think it will be a great experience, but also because I enjoy meeting other math majors and fellow undergraduate students. Please come visit me if you have any questions or concerns that I could help you with. I would love to meet you!”

To contact the peer adviser, send email to:  
[peer@math.ucdavis.edu](mailto:peer@math.ucdavis.edu)

# Outstanding Graduate Student Teaching Award

For the second year in a row we have had three of our students receive the Outstanding Graduate Student Teaching Award. We continue to be impressed by the caliber of our students and are proud to see so many of them receiving campus recognition.



## Eva M. Strawbridge, Ph.D. Candidate, 2008

Eva began her Ph.D. studies in Fall 2004. Eva, who has been a major contributor to the success of the Explore Math Program, was nominated for this teaching award by Brandy Wieggers, the 2006-07 coordinator. To follow are just a few of the many noteworthy comments received on her behalf.

“Mrs. Strawbridge’s participation in the program and performances as a Explore Math fellow can only be described as exceptional.”

“Eva is an excellent teacher who has used her teaching skills to lead a course for undergraduates, to train those undergraduates to work with high school students to participate in the MCM. Beyond her success with this course, Eva has guaranteed the future success of the MME program through her work recording and transferring the MME program over to her successor.”



Diana at the grad welcome hoe-down

## Diana Webb, M.A., Winter 2008

Diana began her studies in Fall 2006. She held a number of Teaching Assistant position as well as an Associate Instructor position. Diana was nominated by Professor Jack Milton with several supporting recommendations. Below is just a taste of the comments received on Diana’s behalf.

“Diana Webb is an exemplary graduate student both in her dedication to the students who are fortunate enough to have her for a teacher and in her efforts to become a better teacher.”

“While I meet truly remarkable Professors and instructors here on campus every year, Diana had inspired the best in me. She has an uncanny ability to stir the interest of mathematics in others.”

“Diana was an excellent teacher and was very responsive to student concerns and questions. I would highly recommend her to other students.”

From Diana, “I am living in Orange, CA. After receiving my M.A. in March, I am teaching full time at Santiago Canyon College in Orange. Next year, I have hopes of moving to Hawaii with my boyfriend and finding a teaching position there.”

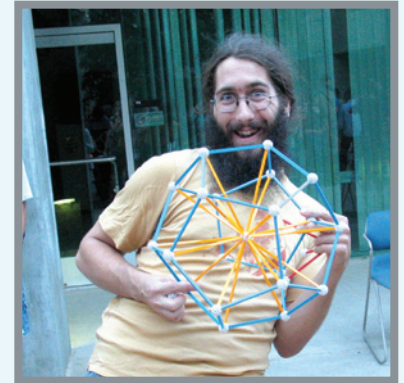

Patrick at the first annual Math Fest

## Patrick Dragon, Ph.D. Candidate, 2008

Patrick began his Ph.D. studies in Fall 2006. He has had the chance to teach as an Associate Instructor as well as serve as a Teaching Assistant. Patrick’s nomination was led by Professor Jesús De Loera and supported by multiple students. Here are a few of the many noteworthy comments received on Patrick’s behalf.

“Patrick’s teaching is truly revolutionary. Not only can I honestly say that I have never had a better teacher in mathematics, I can honestly say I have never had a better teacher in any course, at any point in my academic career.”

“I loved absolutely everything about Mr. Dragon’s teaching style and philosophy. He should serve as a model of a good instructor.”

“In all my career I have never seen such a natural teacher. Patrick is truly full of enthusiasm and love for communicating mathematics. His abilities to teach are beyond anything I have seen before and he is getting better every day!”

From Patrick, “I’m starting my third year, and finally understand the meaning of ‘hitting the ground running.’ This year, my research with Prof. Schwarz is kicking into gear while I try to finish up coursework and schedule THE QUALS. I look forward to teaching next summer, as my fellowship prohibits this during the school year. I was also the recipient of the Departmental W. K. Schwarze fellowship for 2008—the application for which was greatly augmented by the OGTA. Overall, life’s good—just never slowing down.”

## Catching Up

Tyler J. Evans (Ph.D. 2000) and Bori Mazzag (Ph.D. 2003) are enjoying life on the Pacific North Coast with their two children Miska, age 6, and Izabella, age 2. They both miss living in Davis, especially the “B Street House” and the Farmer’s Market. Tyler is presently an associate professor at Humboldt State University, where he has worked since 2001.

Karen (Peterson) Nelson (B.A. 1968 in Math) completed her M.S. at Cal State Hayward in 2004. She spent a year of lecturing at Hayward, and another year as adjunct faculty at Las Positas Community College. She is presently a part-time lecturer at Maui Community College in Kahului, HI on the scenic island of Maui.

# A New Math Model for the Community

This year Brandy Wieggers received the UC Davis Chancellor's Achievement Award for Diversity and Community for 2007-08 in the Graduate Student category, as well as the 2007-08 Outstanding Graduate Student Community Service Award. These awards recognize Brandy's contributions to enhancing inclusiveness and diversity at the University of California, Davis. More specifically, they recognize Brandy's work creating and leading the Department of Mathematics' Explore Math program, founding and leading the UC Davis Graduate Student Community Service Committee (GSCSC) and her work in developing and directing the Oakland/East Bay Math Circle and Circle for Teachers under the umbrella of the Mathematical Sciences Research Institute (MSRI) in Berkeley. Brandy is the third graduate student in our Department to be honored with this award (Momar Dieng and Yvonne Lai were previous recipients).

Brandy has demonstrated an incredible drive to improve the community around her. She created and ran a multi-week Professional Development Seminar that brought together faculty and older students to share collective job market advice with younger students; she has served for several years as Member-at-Large of the math Graduate Students Association; and she even hosted (in her own home) a student-run reception for new recruits!

If there is one theme that unites Brandy's work, it is a dedication to reach out to all community members and to inspire others to share their expertise with each other so as to benefit the community as a whole. When Brandy joined the Explore Math program, she improved its structure so the directors of its constituent activities worked as a cohesive team. Under her leadership, the Explore Math program has received national recognition. She was subsequently named by the interna-



tionally-renowned Mathematical Sciences Research Institute as their National Math Circle Coordinator and the Director of the outreach program Oakland/East Bay Math Circle. In the university community, she created and chaired the Graduate Student Community Service Committee, which has provided volunteers to more than 40 events since its founding; and she co-founded the Graduate Student Leaders Committee, which has facilitated coordination and communication among and provided a peer support network for student leaders across campus. She met with and convinced higher administration to have UC Davis join the national Campus Compact community service and civic engagement organization.

Brandy's phenomenal commitment to outreach efforts is exemplified by the variety of people who have benefitted from her actions: pre-college students in the Sacramento and Bay Area, her Department, her fellow graduate students, and the university as a whole.

Having completed her dissertation this summer, Brandy accepted the position at the Mathematical Sciences Research Institute as their Math Circle Coordinator. In this role Brandy will lead their effort to create a national organization of Math Circles and similar programs, while also directing the Oakland/East Bay Math Circle and Circle for Teachers and serving as the associate director of the San Francisco Math Circle and Circle for Teachers. Brandy looks forward to living in the San Francisco Bay Area, continuing to be involved with Math Circles and other mathematical outreach programs while also maintaining her mathematical biology work. If you're interested in finding out more about any of these programs you should contact Brandy:

[brandy@msri.org](mailto:brandy@msri.org)

# Catching Up

**David W. Birdsall** (B.S. 1976) has spent 30 years in the computer industry working on operating systems, compilers, and communication networks. The last 25 have been spent on relational database engines. From 1988 through 2006, he was part of Tandem, Compaq, and HP's NonStop SQL™ group working on the runtime engine, catalog manager, and utilities. Most recently, he has been an architect for HP's Neoview product, with a focus on manageability, but contributing to all areas of the product.

His daughter, Sarah, is now a freshman at UC Davis majoring in Dramatic Arts, and he keeps encouraging her to take some calculus.

David is interested in hearing what his former professors are up to. Profs. Borges, Barnette, Milton, Cutler, Banks, Chakarian, Sallee, Silvia, Norton, Glauz and Tamura all stand out in his mind as people he enjoyed and learned greatly from. He also likes to hear about contemporary alumni.

**Seth Adam Stevelman** (B.S. 1998 in Math/B.A. in Poli. Sci.), after a stint at Harvard, has moved on from his position as attorney at Mitchell Silberberg & Knupp. He has become counsel in labor relations for ABC in Burbank, California. He is still married to his wife, Jennifer, and his daughter Chloe continues to grow.

# Are You Alumni?

We want to hear from you! Please send us information about yourself so that we can stay in touch and share in your experiences outside of UC Davis.

Please complete our Alumni Questionnaire under "Contact Us" at:

<http://www.math.ucdavis.edu/>

or send e-mail to:

[mso@math.ucdavis.edu](mailto:mso@math.ucdavis.edu)

We will do our best to include it in the next newsletter.

# 2007-08 Department Awards Ceremony



Prof. Ali Dad-del

On June 11, 2008, the Department honored award recipients among the faculty, staff and students.

## G. Thomas Sallee Mathematics Teaching Award

The G. Thomas Sallee Mathematics Teaching Award was named in recognition of Professor Emeritus Tom Sallee's 40-yr career with the Department. Recipients of this award are drawn from instructors who have taught the Department's lower-division courses over the past year. Associate instructors, visiting instructors, lecturers, and regular faculty are eligible.

This year's award went to Professor Ali Dad-Del, who was selected by the Department's Awards Committee after having reviewed course evaluations and student comments.



Adam Sorkin

## Spring Mathematics Contest and G. Thomas Sallee Prize Winners

Held annually and funded through two endowments, the Spring Mathematics Contest and the G. Thomas Sallee Prize are open to all undergraduate students enrolled at UC Davis. Winners of these competitions are determined after having completed an exam designed by the Department's Mathematics Contest Committee. Awards for these categories went to George Barnett, Andy Huang, and Adam Sorkin.



Andy Huang

## Henry L. Alder Prize for Excellence in Teaching

Professor Henry Alder was an active member of our Department from 1948 to 1994. Even in retirement, Professor Alder continued to teach and be a strong advocate for quality teaching almost until his death in 2002. Part of his legacy is an endowment known as The Henry L. Alder Graduate Fellowship in Mathematics, providing support for our graduate students through the Henry L. Alder Prize for Excellence in Teaching. This prize is given each year to the person deemed the top teacher among all graduate students in mathematics.

This year's recipient was Julie Blackwood. In Summer 2007, Julie taught 16C, earning an evaluation rating of 4.9 for overall teaching knowledge and 4.8 for overall quality of the course. These ratings were the highest of all classes taught by graduate students for the 2007-08 academic year.

Even more remarkable, she taught the course at the end of her first year. Her accomplishment has not gone unnoticed by her teaching mentor, Professor Tim Lewis, who described her as "a natural teacher."



George Barnett



Julie Blackwood

## Alice Leung Scholarship in Mathematics

Alice Siu-Fun Leung received an M.A. in Math in 1975 from UC Davis. She spoke very highly of her experience at UC Davis. In her will, Ms. Leung generously provided an endowment to award scholarships annually to graduate students in Mathematics. This award is given to students who have shown exceptional promise in all aspects of mathematics, including research, scholarship and teaching.

Deanna Needell won, and lived up to the promise of math research that is essential for this award. She has already begun to master techniques of the newly developed and competitive research area of signal processing called Compressed Sensing. As testament to her knowledge, she has been a guest speaker at the 2007 SPIE Computational Imaging Conference and the 2008 SIAM Imaging Science Conference.

Deanna has also worked diligently alongside her faculty mentor, Professor Roman Vershynin, studying Geometric Functional Analysis. Professor Vershynin remarked, "It should be quite hard even for a bright student to master two completely different fields in two years, but that is what Deanna successfully did."

Deanna approaches research with care and attention to detail. Her long list of accomplishments includes being four-time recipient of the UC Davis Humanities Graduate Research Award, two-time recipient of the Graduate Student Mentorship Award, and an E.W.B. Math and Science Scholarship.

Deanna is a very talented scholar who shows a great deal of depth, originality, productivity, and an unequalled independence in mathematical research.

## Evelyn M. Silvia Scholarship for Future Mathematics Teachers

This scholarship was established through generous donations from family and friends of the late Professor Evelyn Silvia. Evelyn was hired in 1973, just following receipt of her Ph.D. from Clark University. During her career at UC Davis, she served as a role model for female faculty. She was extremely generous with her time whether it was as a campus committee member or an adviser assisting a student.

This scholarship honors Silvia's memory by recognizing a junior or senior with a major in mathematics, applied mathematics or statistics who has shown an interest in teaching mathematics through their academics and application materials. This year's prize went to Courtney Dostie.

## Robert Lewis Wasser Prize

Robert Lewis Wasser was born in 1973 in Sacramento. He excelled in all that he did and was selected as a National Merit Scholar in 1991, and a participant in the Academic Decathlon. In 1991, Robert began his studies at UC Davis where he quickly became one of the few students in our Department who had already taken as a sophomore some of our most challenging upper-division courses.

After his tragic death in an automobile accident in 1993, his grandmother initiated the Robert Lewis Wasser Endowment in his memory. Its goal is to benefit promising mathematics students at UC Davis. The Department was pleased to award this year's prize to Matthew Vicksell.

## Eric C. Ruliffson Scholarship in Mathematics

Eric Ruliffson attended UC Davis from 1964-1968, loved the study of math, and excelled in it. After graduation, he joined the actuarial department of Pacific Mutual Insurance. After serving in the Navy, Eric attended graduate school in demography at UC Berkeley. He later was a benefits consultant at Coopers and Lybrand. He became a partner with the firm, achieving the status of Fellow in the Society of Actuaries. He was elected to the Board of Partners for Coopers and Lybrand, the first actuary to be so honored, and served on the Board of Partners for PricewaterhouseCoopers, the world's largest consulting firm.

For academic accomplishments and the Awards Committee's evaluation of his potential for future achievement, the award was given to Ying Wang.

## William Karl Schwarze Scholarship

In honor of William Karl Schwarze, a Mathematics student with the Department and a lifelong humanitarian, this award is given to graduate students in Mathematics who have demonstrated outstanding mathematical scholarship and exceptional promise of making a strong professional contribution as a mathematics teacher and educator at the pre-college or college level.

The award went to Patrick Dragon, who began his graduate studies in Fall 2006. In that short time, he made significant contributions as a teaching assistant and associate instructor, devoted to helping others understand material they are learning. Professor Ali Dad-Del commended, "His interest and dedication to teaching and his talent in communication with students make him a very competent teacher."

Always looking for ways to improve, Patrick has been working closely with Rick West at the Learning

Skills Center to learn the Socratic method of teaching, which emphasizes teaching by asking questions.

"It's things like this that make my job the best job in the world," Patrick stated. "I've found something I'm good at, something I'm appreciated for and can devote myself to. Something I love."

## Departmental Citations

These citations recognize the very top graduates of our undergraduate program, who have taken a very strong selection of mathematics courses, distinguished themselves with exceptionally high grade point averages, and received enthusiastic endorsements from the faculty. Joshua Burkhart, Shu-Yu "Philip" Chang, Kathryn Crawford, Luis De La Torre, Andrey Goder, Matthew Holden, Amanda O'Rourke, Pamela Patterson, Shad Pierson, Adam Sorkin, and Amanda Young were among this year's winners.

## Galois Group Award

Known as "the official voice of the graduate students in Mathematics," the Galois Group is how graduate students in mathematics communicate with the Department. Every year, the Galois Group presents an award to recognize outstanding service or commitment to the Group. This year's award went to Perry A. Gee, one of the Department's staff advisers with the Student Services Office.

## Special Departmental Recognition

A very special Department award was given to Yvonne Lai for her exceptional contributions to the Galois Group, her generous service to the community of graduate students in the Department of Mathematics, and for her tireless efforts to establish better communication between the students and the faculty.

## Acknowledgements of Other Campus Awards

The Department congratulates Mohamed Omar, David Sivakoff, Eva Strawbridge, and Brandy Wieggers for receiving the 2008 Community Service Award from the UC Davis Community Service Office. We'd also like to recognize Matthew Holden for being named a University Medal Award winner, and Chelsea Hertzog for being named this year's Mary Jeanne Gilhooly Award winner.

Lastly, we congratulate Karen Chipman, Allison O'Hair, Justin Sunu, Larissa Fitchett, Kurtis Keller, Trevor Jha, Christy Holl and Valarie Rothfus. Each of these students served on a team during the recent Mathematical Contest in Modeling and received Team Distinction Awards for their efforts.



Deanna Needell

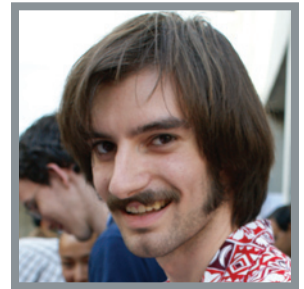

Matthew Vicksell



Patrick Dragon



Perry Gee



Yvonne Lai

# Focus on Emeritus Kurt Kreith

Freshman seminars and COSMOS continue to provide outlets for Emeritus Professor Kurt Kreith's interests in classroom instruction. During 2007-08 his freshman seminars dealt with arithmetic, human migration, and cryptography, while his 2008 COSMOS course was "An Introduction To Discrete Dynamical Systems."

Engaged by the fact that the German Ministry of Education had designated 2008 as the "Year of Mathematics," Kurt also attended the 2008 Jahrestagung of the German Mathematical Society in Erlangen. This meeting was accompanied by expositions throughout Germany, including one entitled "Zahlen, Messen, Rechnen" at the State Library in Bamberg. There, in an eerily darkened room, one encounters books going back to the 8<sup>th</sup> century from which our computational mathematics evolved. Included are the books of Christoph Clavius (a native of Bamberg) and a copy of Gregorius Reisch's *Philosophica Mathematica* with its famous woodcuts. Kurt has a hand-

some catalog from this exposition that colleagues are welcome to examine.

Erlangen was the site of a rather different exposition entitled "Jewish Mathematicians in German-speaking Academic Culture." Some painful episodes in German mathematics are explored and a range of books displayed. Notable was Otto Toeplitz's *Von Zahlen und Figuren*, an expository work on which Peter Lax and John von Neuman are said to have cut their milk teeth (Our COSMOS students now encounter this book in English translation). Kurt expects to receive a catalog from this exposition in October.

Travel to Erlangen involved a layover in Berlin, a city filled with vivid reminders for many people. In 1955, having been obligated to interrupt his graduate studies for a stint with the military, Kurt found

himself assigned to an army intelligence unit with operations in what was then West Berlin. Unwilling to engage in some of the practices called for by such information gathering, he was assigned to a unit housed in the IG Farben building in Frankfurt. Here he used his 2-finger typing skills to process intelligence data.

In the fall of 1956 Kurt was able to return to Berkeley to resume his graduate studies. One of the first people he encountered there was Derrick Lehmer who asked the obvious question: "So, was your serial number prime?"



Kreith, at far left, with part of his COSMOS Cluster



Kollegienhaus der Universität Erlangen, Germany

## Staff News

by Jessica Potts, Department Manager

This year brought several transitions. Our Department Manager, Tracy Ligtenberg, went to Vet Med. Business Manager Richard Edmiston moved to the Univ. of Arizona in his hometown of Tuscon. After 14 months away, I have returned, now as Department Manager.

In June 2008, Jessica Goodall and Tina Denena were promoted to team Business Managers. Connie Dani transitioned to a hybrid Student/Business Services position. After several office moves everyone seems to be settling into their new jobs nicely.

Our staffing in the technical area has stayed steady. We continue to automate administrative tasks and are thankful to have such a great technical team. The computer team completed an online decision archiving tool as well as an online voting tool for use by Academic Personnel. We hope to have an online graduate annual review tool in 2009.

Carol Crabill is flying solo during the Fall while DeAnn Ronning is out on maternity

leave. With over 20 merit and promotion actions, Carol is sure to stay busy!

Anchoring our Student Services unit are Celia Davis and Perry Gee. This year they're busy with the site visit for the Graduate Program Committee.

Karen Beverlin continues as Assistant Editor for the Journal of Mathematical Physics. Karen also publishes our quarterly Plus or Minus e-newsletter.

In 2007 we hired POP candidate, Alla Savrassova, as our Department Assistant. Alla's position was extended this year and she continues to learn more about our Department.

I was excited to return and am truly thrilled to be working with such an amazing team. Here's to another great year.



From left to right: Jessica Potts, Zach Johnson, Leng Siakkhasone, Marianne Waage, Celia Davis, Karen Beverlin, Jessica Goodall, Connie Dani, Tina Denena, DeAnn Ronning, Perry Gee, Carol Crabill, Alla Savrassova

### Academic Personnel

Carol Crabill, DeAnn Ronning

### Business Services

Tina Denena, Jessica Goodall, Alla Savrassova

### Department Manager

Jessica Potts

### Student Services

Connie Dani, Celia Davis, Perry Gee

### Technical Services

Zach Johnson, Leng Siakkhasone, Marianne Waage

### Journal of Mathematical Physics

Karen Beverlin

# Life After Davis

## Jason Brown

B.A. in Mathematics, 1988

Attending UC Davis was a wonderful experience. I was away from family, experiencing college life, going to a great school and studying a subject I dearly loved and found “easy.” I was in a fraternity and on the golf team (2 time All-American and teammate of current Aggie Golf Coach Cy Williams).

I was fortunate to get a job in the Math Department grading papers and tutoring calculus. I loved teaching and tutoring. I got paid for doing something fun! During summers I worked for the Agriculture Division of Shell Oil Company in Modesto as a field technician. Field technician is short for a guy who measures corn stalks with a caliper on hands and knees in 100+ degree heat wearing a full-body, dry suit shouting out measurements while your colleague, in a similar suit, enters numbers into a massive “hand-held” computer. Life was good...then graduation came and reality set in.

I decided to follow in my father's footsteps (also a UC Davis Math alumni) and get a Ph.D. My dad had an interesting job as a statistician, so I decided to go to graduate school in Statistics. I thought it would be more applicable to getting a job in the real world. I narrowed it down to the Univ. of Wisconsin at Madison or The Univ. of North Carolina at Chapel Hill.

Being a California boy, I felt that I would not do well in the harsh winters of Wisconsin, so off to North Carolina I went. Graduate school is much more difficult than undergraduate school. I studied all the time, spent most of my days and nights in my office, and was rewarded with good grades and a Ph.D. To help with the cost of school, I was a teaching assistant and also worked at SAS Institute during the summers. Both were great experiences. I ended up getting a degree in Theoretical Statistics, not exactly a launching pad into getting a “real” job.

After graduation, I had a choice, continue to work at SAS Institute but now as a Research Statistician in charge of coding and enhancing one of their modules, or go teach at the University of Missouri in Columbia. I dearly loved teaching and explaining technical topics to non-technical people, but I was equally enamored with computers and programming (I had been programming since age 14, back when Apple Ataris stored your programs on

cassette tape).

I chose to continue teaching and research. I felt if I did not do this now, I would not have another opportunity. I went to Columbia and headed up their computer lab, teaching Stochastic Processes and Business Statistics. I continued my research, received some grants, and started running. I eventually ran the St. Louis Marathon in 3:21. I throw myself into anything I do. I was taught to give 110% in whatever you do. After a year and a half, I really missed programming and, though I was doing well at teaching, it was not to be my passion.

I moved back to North Carolina and got a job as a Statistician for a military consulting company, Applied Mathematics. The commercial world sure paid a lot more! Working out of Raleigh, I wrote search and rescue algorithms for the Coast Guard using the buoy movements over time to determine likely locations of where a capsized person would be after a certain amount of time, if they started in a particular region. It was directly related to my Ph.D. topic and I got to program. Life was good again, except I was the only one in the office, and in a military environment working on top secret stuff, there were no windows and no Internet connection. I did not last long at that job, as I liked to be around people. Staring at four walls 9 hours a day is not my idea of fun. You need to love what you do so that your job is not a job, it is enjoyment.

I decided to really go after programming and got a job with an Internet start-up, Persimmon IT, that was developing the first state-based web server. I worked with the head of R&D to make a programming language to write web database applications using this technology. I got to run a few mammoth projects as well, like PoliticsNow for the Washington Post.

I was not using my Math and Statistics background, but I took solace in the fact that those two disciplines taught me to “think” and problem solve. There is more than one way to solve a problem, if you look at it from many different angles and perspectives, and sooner or later you will find at least one path to your goal and you can choose the most efficient one that suits your needs. I was at Persimmon



IT for quite a few years, learning more about computers, leadership, managing projects and people, and most importantly learning about business politics.

I continued to learn at my next series of jobs, and, in the end, becoming Chief Technology Officer for an online payroll company, Allectis, that also offered all types of telecommunications offerings (dial-up, DSL, T1s, etc.). We built the first online payroll application that calculated the employer and employee total liability before actually processing the payroll. The application heavily used JavaScript (in a dynamic way before Dynamic HTML) and a neat little technology called Cold Fusion.

The telecom industry busted and so did Allectis. The Chief Financial Officer and I started a new company, Employer Payment Solutions, offering online payroll processing. We had one office in Raleigh and another in New York. To protect our intellectual property, I developed a way to acquire the information at both locations and use them at a third. Little did I know then that this was a type of web service, before there was such a thing as web services. We did not have a lot of money, but we were having fun. We acquired a few customers, but not enough to pay for both of us.

A friend of mine from Persimmon IT called me up and asked if I would move to Pittsburgh to be in charge of software development. After a lot of his recruiting and the lure of living in a big city, I decided this was a good opportunity. And here I am today, at CombineNet in Pittsburgh. I have never been around a company with such awesome and game changing technology.

I have lived in many places in the United States, traveled all around the globe for my work (England, France, Germany, Sweden, Turkey, India, China, Japan, Singapore), learned many things about life and business, but I always fondly remember my days at Davis for providing me with the love of teaching, an appreciation of thought, and a passion for always considering “what if.”

**1015 Department of Mathematics  
University of California  
One Shields Avenue  
Davis, CA 95616-8633**

Address Service Requested

Nonprofit Org  
U.S. Postage  
**PAID**  
UC Davis

## Donations

Your gift is welcome! The Department of Mathematics wishes to thank all alumni, parents, students, faculty, staff, and friends who support the Department. For a complete list of all our endowed funds, please see our web site:

<http://www.math.ucdavis.edu/contact/donation/>

Your gift to the Department is tax deductible, and you can choose to have your name published, or remain anonymous.

Your gift will be used to support the Department's greatest needs. These may include undergraduate and graduate support, research support, or departmental initiatives.

## A Special Thanks!

We would like to give a special thanks to Marion E. McCurdy who has established the McCurdy Family Scholarship. This scholarship is based on academic merit and promise and will benefit our undergraduates with a junior or senior class standing.

If you are interested in donating to our department or setting up a scholarship please review our donation information located on the left.

### Newsletter Committee:

Craig Benham, Editor

Jessica Potts, Management Services Officer

Marianne Waage, Designer