

Toric Varieties

David Cox

John Little

Hal Schenck

DEPARTMENT OF MATHEMATICS, AMHERST COLLEGE, AMHERST, MA
01002

E-mail address: `dac@cs.amherst.edu`

DEPARTMENT OF MATHEMATICS AND COMPUTER SCIENCE, COLLEGE OF
THE HOLY CROSS, WORCESTER, MA 01610

E-mail address: `little@mathcs.holycross.edu`

DEPARTMENT OF MATHEMATICS, UNIVERSITY OF ILLINOIS AT URBANA-
CHAMPAIGN, URBANA, IL 61801

E-mail address: `schenck@math.uiuc.edu`

Preface

The study of toric varieties is a wonderful part of algebraic geometry that has deep connections with polyhedral geometry. Our book is an introduction to this rich subject that assumes only a modest knowledge of algebraic geometry. There are elegant theorems, unexpected applications, and, as noted by Fulton [58], “toric varieties have provided a remarkably fertile testing ground for general theories.”

The Current Version. The January 2010 version consists of seven chapters:

- Chapter 1: Affine Toric Varieties
- Chapter 2: Projective Toric Varieties
- Chapter 3: Normal Toric Varieties
- Chapter 4: Divisors on Toric Varieties
- Chapter 5: Homogeneous Coordinates
- Chapter 6: Line Bundles on Toric Varieties
- Chapter 7: Projective Toric Morphisms

These are the chapters included in the version you downloaded. The book also has a list of notation, a bibliography, and an index, all of which will appear in more polished form in the published version of the book. Two versions are available on-line. We recommend using postscript version since it has superior quality.

Changes to the January 2009 Version. The new version fixes some typographical errors and includes a few new examples, new exercises and some rewritten proofs.

The Rest of the Book. Five chapters are in various stages of completion:

- Chapter 8: The Canonical Divisor of a Toric Variety
- Chapter 9: Sheaf Cohomology of Toric Varieties

- Chapter 10: Toric Surfaces
- Chapter 11: Resolutions and Singularities
- Chapter 12: The Topology of Toric Varieties

When the book is completed in August 2010, there will be three final chapters:

- Chapter 13: The Riemann-Roch Theorem
- Chapter 14: Geometric Invariant Theory
- Chapter 15: The Toric Minimal Model Program

Prerequisites. The text assumes the material covered in basic graduate courses in algebra, topology, and complex analysis. In addition, we assume that the reader has had some previous experience with algebraic geometry, at the level of any of the following texts:

- *Ideals, Varieties and Algorithms* by Cox, Little and O’Shea [35]
- *Introduction to Algebraic Geometry* by Hassett [79]
- *Elementary Algebraic Geometry* by Hulek [91]
- *Undergraduate Algebraic Geometry* by Reid [146]
- *Computational Algebraic Geometry* by Schenck [153]
- *An Invitation to Algebraic Geometry* by Smith, Kahanpää, Kekäläinen and Traves [158]

Readers who have studied more sophisticated texts such as Harris [76], Hartshorne [77] or Shafarevich [152] certainly have the background needed to read our book.

We should also mention that Chapter 9 uses some basic facts from algebraic topology. The books by Hatcher [80] and Munkres [128] are useful references.

Background Sections. Since we do not assume a complete knowledge of algebraic geometry, Chapters 1–9 each begin with a background section that introduces the definitions and theorems from algebraic geometry that are needed to understand the chapter. The remaining chapters do not have background sections. For some of the chapters, no further background is necessary, while for others, the material more sophisticated and the requisite background will be provided by careful references to the literature.

The Structure of the Text. We number theorems, propositions and equations based on the chapter and the section. Thus §3.2 refers to section 2 of Chapter 3, and Theorem 3.2.6 and equation (3.2.6) appear in this section. The end (or absence) of a proof is indicated by \square , and the end of an example is indicated by \diamond .

For the Instructor. We do not yet have a clear idea of how many chapters can be covered in a given course. This will depend on both the length of the course and the level of the students. One reason for posting this preliminary version on

the internet is our hope that you will teach from the book and give us feedback about what worked, what didn't, how much you covered, and how much algebraic geometry your students knew at the beginning of the course. Also let us know if the book works for students who know very little algebraic geometry. We look forward to hearing from you!

For the Student. The book assumes that you will be an active reader. This means in particular that you should do tons of exercises—this is the best way to learn about toric varieties. For students with a more modest background in algebraic geometry, reading the book requires a commitment to learn *both* toric varieties *and* algebraic geometry. It will be a lot of work, but it's worth the effort. This is a great subject.

What's Missing. Right now, we do not discuss the history of toric varieties, nor do we give detailed notes about how results in the text relate to the literature. We would be interesting in hearing from readers about whether these items should be included.

Please Give Us Feedback. We urge all readers to let us know about:

- Typographical and mathematical errors.
- Unclear proofs.
- Omitted references.
- Topics not in the book that should be covered.
- Places where we do not give proper credit.

As we said above, we look forward to hearing from you!

January 2010

David Cox
John Little
Hal Schenck

Contents

Preface	iii
Notation	xi
Part I: Basic Theory of Toric Varieties	1
Chapter 1. Affine Toric Varieties	3
§1.0. Background: Affine Varieties	3
§1.1. Introduction to Affine Toric Varieties	10
§1.2. Cones and Affine Toric Varieties	23
§1.3. Properties of Affine Toric Varieties	35
Appendix: Tensor Products of Coordinate Rings	48
Chapter 2. Projective Toric Varieties	49
§2.0. Background: Projective Varieties	49
§2.1. Lattice Points and Projective Toric Varieties	54
§2.2. Lattice Points and Polytopes	62
§2.3. Polytopes and Projective Toric Varieties	74
§2.4. Properties of Projective Toric Varieties	85
Chapter 3. Normal Toric Varieties	93
§3.0. Background: Abstract Varieties	93
§3.1. Fans and Normal Toric Varieties	105
§3.2. The Orbit-Cone Correspondence	114
§3.3. Toric Morphisms	125
§3.4. Complete and Proper	139

Appendix: Nonnormal Toric Varieties	149
Chapter 4. Divisors on Toric Varieties	153
§4.0. Background: Valuations, Divisors and Sheaves	153
§4.1. Weil Divisors on Toric Varieties	168
§4.2. Cartier Divisors on Toric Varieties	174
§4.3. The Sheaf of a Torus-Invariant Divisor	187
Chapter 5. Homogeneous Coordinates	193
§5.0. Background: Quotients in Algebraic Geometry	193
§5.1. Quotient Constructions of Toric Varieties	203
§5.2. The Total Coordinate Ring	217
§5.3. Sheaves on Toric Varieties	224
§5.4. Homogenization and Polytopes	230
Chapter 6. Line Bundles on Toric Varieties	243
§6.0. Background: Sheaves and Line Bundles	243
§6.1. Ample Divisors on Complete Toric Varieties	260
§6.2. The Nef and Mori Cones	279
§6.3. The Simplicial Case	290
Appendix: Quasicoherent Sheaves on Toric Varieties	301
Chapter 7. Projective Toric Morphisms	305
§7.0. Background: Quasiprojective Varieties and Projective Morphisms	305
§7.1. Polyhedra and Toric Varieties	309
§7.2. Projective Morphisms and Toric Varieties	318
§7.3. Projective Bundles and Toric Varieties	324
Appendix: More on Projective Morphisms	334
Chapter 8. The Canonical Divisor of a Toric Variety	339
§8.0. Background: Reflexive Sheaves and Differential Forms	339
§8.1. One-Forms on Toric Varieties	350
§8.2. Differential Forms on Toric Varieties	357
§8.3. Fano Toric Varieties	371
Chapter 9. Sheaf Cohomology of Toric Varieties	379
§9.0. Background: Cohomology	379
§9.1. Cohomology of Toric Divisors	390
§9.2. Vanishing Theorems I	402

§9.3. Vanishing Theorems II	413
§9.4. Applications to Lattice Polytopes	422
§9.5. Local Cohomology and the Total Coordinate Ring	434
Appendix: Introduction to Spectral Sequences	447
Topics in Toric Geometry	379
Chapter 10. Toric Surfaces	453
§10.1. Singularities of Toric Surfaces and Their Resolutions	453
§10.2. Continued Fractions and Toric Surfaces	462
§10.3. Gröbner Fans and McKay Correspondences	472
§10.4. Smooth Toric Surfaces	481
§10.5. Riemann-Roch and Lattice Polygons	489
Chapter 11. Resolutions and Singularities	499
§11.1. Toric Resolution of Singularities	499
§11.2. Other Types of Resolutions	510
§11.3. Rees Algebras and Multiplier Ideals	519
§11.4. Toric Singularities	530
Chapter 12. The Topology of Toric Varieties	545
§12.1. Homotopy of Toric Varieties	545
§12.2. The Moment Map	552
§12.3. Singular Cohomology of Toric Varieties	557
§12.4. The Cohomology Ring	569
§12.5. Complements	583
Chapter 13. The Riemann-Roch Theorem	595
Chapter 14. Geometric Invariant Theory	597
Chapter 15. The Toric Minimal Model Program	599
Bibliography	601
Index	609

Notation

Basic Notions

$\mathbb{Z}, \mathbb{Q}, \mathbb{R}, \mathbb{C}$	integers, rational numbers, real numbers, complex numbers
\mathbb{N}	semigroup of nonnegative integers $\{0, 1, 2, \dots\}$
im, ker	image and kernel
\varinjlim	direct limit
\varprojlim	inverse limit

Rings and Varieties

$\mathbb{C}[x_1, \dots, x_n]$	polynomial ring in n variables
$\mathbb{C}[[x_1, \dots, x_n]]$	formal power series ring in n variables
$\mathbb{C}[x_1^{\pm 1}, \dots, x_n^{\pm 1}]$	ring of Laurent polynomials
$\mathbf{V}(I)$	affine or projective variety of an ideal
$\mathbf{I}(V)$	ideal of an affine or projective variety
$\mathbb{C}[V]$	coordinate ring of an affine or projective variety
$\mathbb{C}[V]_d$	graded piece in degree d when V is projective
$\mathbb{C}(V)$	field of rational functions when V is irreducible
$\text{Spec}(R)$	affine variety of coordinate ring R
$\text{Proj}(S)$	projective variety of graded ring S
V_f	subset of an affine variety V where $f \neq 0$
$R_f, R_S, R_{\mathfrak{p}}$	localization of R at f , a multiplicative set S , a prime ideal \mathfrak{p}
R'	integral closure of the integral domain R

\widehat{R}	completion of local ring R
$\mathcal{O}_{V,p}, \mathfrak{m}_{V,p}$	local ring of a variety at a point and its maximal ideal
$T_p(V)$	Zariski tangent space of a variety at a point
$\dim V, \dim_p V$	dimension of a variety and dimension at a point
\overline{S}	Zariski closure of S in a variety
$X \times Y$	product of varieties
$R \otimes_{\mathbb{C}} S$	tensor product of rings over \mathbb{C}
$X \times_S Y$	fiber product of varieties
\widehat{V}	affine cone of a projective variety
Δ	diagonal map $X \rightarrow X \times X$
$\text{Sing}(X)$	singular locus of a variety

Semigroups

I_L	lattice ideal of lattice $L \subseteq \mathbb{Z}^s$
$\mathbb{Z}\mathcal{A}$	lattice generated by \mathcal{A}
$\mathbb{Z}'\mathcal{A}$	elements $\sum_{i=1}^s a_i m_i \in \mathbb{Z}\mathcal{A}$ with $\sum_{i=1}^s a_i = 0$
$\mathbb{N}\mathcal{A}$	affine semigroup generated by \mathcal{A}
S	affine semigroup
$S_\sigma = S_{\sigma, N}$	affine semigroup $\sigma^\vee \cap M$
$\mathbb{C}[S]$	semigroup algebra of S
\mathcal{H}	Hilbert basis of S_σ when σ is strongly convex

Cones and Fans

$\text{Cone}(S)$	convex cone generated by S
σ	rational convex polyhedral cone in $N_{\mathbb{R}}$
$\text{Span}(\sigma)$	subspace spanned by σ
$\dim \sigma$	dimension of σ
σ^\vee	dual cone of σ
$\text{Relint}(\sigma)$	relative interior of σ
$\text{Int}(\sigma)$	interior of σ when $\text{Span}(\sigma) = N_{\mathbb{R}}$
σ^\perp	set of $m \in M_{\mathbb{R}}$ with $\langle m, \sigma \rangle = 0$
$\tau \preceq \sigma, \tau \prec \sigma$	τ is a face or proper face of σ
τ^*	face of σ^\vee dual to $\tau \subseteq \sigma$, equal to $\sigma^\vee \cap \tau^\perp$
H_m	hyperplane in $N_{\mathbb{R}}$ defined by $\langle m, - \rangle = 0, m \in M_{\mathbb{R}} \setminus \{0\}$
H_m^+	half-space in $N_{\mathbb{R}}$ defined by $\langle m, - \rangle \geq 0, m \in M_{\mathbb{R}} \setminus \{0\}$

Σ	fan in $N_{\mathbb{R}}$
$\Sigma(r)$	r -dimensional cones of Σ
u_{ρ}	minimal generator of $\rho \cap N$, $\rho \in \Sigma(1)$
Σ_{\max}	maximal cones of Σ
N_{σ}	sublattice $\mathbb{Z}(\sigma \cap N) = \text{Span}(\sigma) \cap N$
$N(\sigma)$	quotient lattice N/N_{σ}
$M(\sigma)$	dual lattice of $N(\sigma)$, equal to $\sigma^{\perp} \cap M$
$\text{Star}(\sigma)$	star of σ , a fan in $N(\sigma)$
$\Sigma^*(\sigma)$	star subdivision of Σ along σ
$\text{ind}(\sigma)$	index of a simplicial cone

Polyhedra

$\text{Conv}(S)$	convex hull of S
P	polytope or polyhedron
$\dim P$	dimension of P
$H_{u,b}$	hyperplane in $M_{\mathbb{R}}$ defined by $\langle -, u \rangle = b$, $u \in N_{\mathbb{R}} \setminus \{0\}$
$H_{u,b}^+$	half-space in $M_{\mathbb{R}}$ defined by $\langle -, u \rangle \geq b$, $u \in N_{\mathbb{R}} \setminus \{0\}$
$Q \preceq P$, $Q \prec P$	Q is a face or proper face of P
P°	dual or polar of a polytope
Δ_n	standard n -simplex
$A + B$	Minkowski sum
kP	multiple of a polytope or polyhedron
$C(P)$	cone over a polytope or polyhedron
σ_Q	cone of a face $Q \preceq P$
Σ_P	normal fan of a polytope or polyhedron
φ_P	support function of a polytope or polyhedron

Toric Varieties

M , χ^m	character lattice of a torus and character of $m \in M$
N , λ^u	lattice of one-parameter subgroups of a torus and one-parameter subgroup of $u \in N$
T_N	torus $N \otimes_{\mathbb{Z}} \mathbb{C}^* = \text{Hom}_{\mathbb{Z}}(M, \mathbb{C}^*)$ associated to N and M
$M_{\mathbb{R}}$, $M_{\mathbb{Q}}$	vector spaces $M \otimes_{\mathbb{Z}} \mathbb{R}$, $M \otimes_{\mathbb{Z}} \mathbb{Q}$ built from M
$N_{\mathbb{R}}$, $N_{\mathbb{Q}}$	vector spaces $N \otimes_{\mathbb{Z}} \mathbb{R}$, $N \otimes_{\mathbb{Z}} \mathbb{Q}$ built from N
$\langle m, u \rangle$	pairing of $m \in M$ or $M_{\mathbb{R}}$ with $u \in N$ or $N_{\mathbb{R}}$
$Y_{\mathcal{A}}$, $X_{\mathcal{A}}$	affine and projective toric variety of $\mathcal{A} \subseteq M$

$U_\sigma = U_{\sigma, N}$	affine toric variety of a cone $\sigma \subseteq N_{\mathbb{R}}$
$X_\Sigma = X_{\Sigma, N}$	toric variety of a fan
X_P	projective toric variety of a lattice polytope or polyhedron
X_D	toric variety of a basepoint free divisor
$\overline{\phi}, \overline{\phi}_{\mathbb{R}}$	lattice homomorphism of a toric morphism $\phi : X_{\Sigma_1} \rightarrow X_{\Sigma_2}$ and its real extension
γ_σ	distinguished point of U_σ
$O(\sigma)$	orbit of $\sigma \in \Sigma$
$V(\sigma) = \overline{O(\sigma)}$	closure of orbit of $\sigma \in \Sigma$, toric variety of $\text{Star}(\sigma)$
$D_\rho = \overline{O(\rho)}$	torus-invariant prime divisor on X_Σ of $\rho \in \Sigma(1)$
D_F	torus-invariant prime divisor on X_P of facet $F \subseteq P$
U_P	affine toric variety of recession cone of a polyhedron
U_Σ	affine toric variety of a fan with convex support

Specific Varieties

$\mathbb{C}^n, \mathbb{P}^n$	affine and projective n -dimensional space
$\mathbb{P}(q_0, \dots, q_n)$	weighted projective space
\mathbb{C}^*	multiplicative group of nonzero complex numbers $\mathbb{C} \setminus \{0\}$
$(\mathbb{C}^*)^n$	standard n -dimensional torus
\widehat{C}_d, C_d	rational normal cone and curve
$\text{Bl}_0(\mathbb{C}^n)$	blowup of \mathbb{C}^n at the origin
$\text{Bl}_{V(\tau)}(X_\Sigma)$	blowup of X_Σ along $V(\tau)$, toric variety of $\Sigma^*(\tau)$
\mathcal{H}_r	Hirzebruch surface
$S_{a,b}$	rational normal scroll

Divisors

$\mathcal{O}_{X,D}$	local ring of a variety at a prime divisor
ν_D	discrete valuation of a prime divisor D
$\text{div}(f)$	principal divisor of a rational function
$D \sim E$	linear equivalence of divisors
$D \geq 0$	effective divisor
$\text{Div}_0(X)$	group of principal divisors on X
$\text{Div}(X)$	group of Weil divisors on X
$\text{Div}_{T_N}(X_\Sigma)$	group of torus-invariant Weil divisors on X_Σ
$\text{CDiv}(X)$	group of Cartier divisors on X

$\text{CDiv}_{T_N}(X_\Sigma)$	group of torus-invariant Cartier divisors on X_Σ
$\text{Cl}(X)$	divisor class group of a normal variety X
$\text{Pic}(X)$	Picard group of a normal variety X
$\text{Supp}(D)$	support of a divisor
$D _U$	restriction of a divisor to an open set
$\{(U_i, f_i)\}$	local data of a Cartier divisor on X
$\{m_\sigma\}_{\sigma \in \Sigma}$	Cartier data of a torus-invariant Cartier divisor on X_Σ
P_D	polyhedron of a torus-invariant divisor
Σ_D	fan associated to a basepoint free divisor
D_P	Cartier divisor of a polytope or polyhedron
φ_D	support function of a Cartier divisor
$\text{SF}(\Sigma, N)$	support functions integral with respect to N

Intersection Products

$\text{deg}(D)$	degree of a divisor on a curve
$D \cdot C$	intersection product of Cartier divisor and complete curve
$D \equiv D', C \equiv C'$	numerically equivalent Cartier divisors and complete curves
$N^1(X), N_1(X)$	$(\text{CDiv}(X)/\equiv) \otimes_{\mathbb{Z}} \mathbb{R}$ and $(Z_1(X)/\equiv) \otimes_{\mathbb{Z}} \mathbb{R}$
$\text{Nef}(X)$	cone in $N^1(X)$ generated by nef divisors
$NE(X)$	cone in $N_1(X)$ generated by complete curves
$\overline{NE}(X)$	Mori cone, equal to the closure of $NE(X)$
$\text{Pic}(X)_{\mathbb{R}}$	$\text{Pic}(X) \otimes_{\mathbb{Z}} \mathbb{R}$
$r(P)$	primitive relation of a primitive collection

Sheaves and Bundles

\mathcal{O}_X	structure sheaf of a variety X
\mathcal{O}_X^*	sheaf of invertible elements of \mathcal{O}_X
$\mathcal{O}_X(D)$	sheaf of a Weil divisor D on X
\mathcal{K}_X	constant sheaf of rational functions when X is irreducible
$\mathcal{F} _U$	restriction of a sheaf to an open set
$\Gamma(U, \mathcal{F})$	sections of a sheaf over an open set
\mathcal{I}_Y	ideal sheaf of a subvariety $Y \subseteq X$
\tilde{M}	sheaf on $\text{Spec}(R)$ of an R -module M
\tilde{M}	sheaf on X_Σ of a graded S -module M
$\mathcal{O}_{X_\Sigma}(\alpha)$	sheaf on X_Σ of the graded S -module $S(\alpha)$

\mathcal{F}_p	stalk of a sheaf at a point
$\mathcal{F} \otimes_{\mathcal{O}_X} \mathcal{G}$	tensor product of sheaves of \mathcal{O}_X -modules
$\mathcal{H}om_{\mathcal{O}_X}(\mathcal{F}, \mathcal{G})$	sheaf of homomorphisms
\mathcal{F}^\vee	dual sheaf of \mathcal{F} , equal to $\mathcal{H}om_{\mathcal{O}_X}(\mathcal{F}, \mathcal{O}_X)$
$\pi : V \rightarrow X$	vector bundle
$\pi : V_{\mathcal{L}} \rightarrow X$	rank 1 vector bundle of a line bundle \mathcal{L}
$f^* \mathcal{L}$	pullback of a line bundle
$\phi_{\mathcal{L}, W}$	map to projective space determined by $W \subseteq \Gamma(X, \mathcal{L})$
$ D $	complete linear system of D
$\Sigma \times D$	fan that gives $V_{\mathcal{L}}$ for $\mathcal{L} = \mathcal{O}_{X_\Sigma}(D)$
$\mathbb{P}(V), \mathbb{P}(\mathcal{E})$	projective bundle of vector bundle or locally free sheaf

Quotients and Homogeneous Coordinates

R^G	ring of invariants of G acting on R
V/G	good geometric quotient
$V//G$	good categorical quotient
S	total coordinate ring of X_Σ
x_ρ	variable in S corresponding to $\rho \in \Sigma(1)$
S_β	graded piece of S in degree $\beta \in \text{Cl}(X_\Sigma)$
$\deg(x^\alpha)$	degree in $\text{Cl}(X_\Sigma)$ of a monomial in S
$x^{\hat{\sigma}}$	monomial generator of B corresponding to $\sigma \in \Sigma$
$B(\Sigma)$	irrelevant ideal of S , generated by the $x^{\hat{\sigma}}$
$Z(\Sigma)$	exceptional set, equal to $\mathbf{V}(B(\Sigma))$
G	group $\text{Hom}_{\mathbb{Z}}(\text{Cl}(X_\Sigma), \mathbb{C}^*)$ used in the quotient construction
$x^{\langle m \rangle}$	Laurent monomial $\prod_{\rho} x_{\rho}^{\langle m, u_{\rho} \rangle}$, $m \in M$
$x^{\langle m, D \rangle}$	homogenization of χ^m , $m \in P_D \cap M$
x_F	facet variable of a facet $F \subseteq P$
$x^{\langle m, P \rangle}$	P -monomial associated to $m \in P \cap M$
$x^{\langle v, P \rangle}$	vertex monomial associated to vertex $v \in P \cap M$
M	graded S -module
$M(\alpha)$	shift of M by $\alpha \in \text{Cl}(X_\Sigma)$

Part I: Basic Theory of Toric Varieties

Chapters 1 to 9 introduce the theory of toric varieties. This part of the book assumes only a minimal amount of algebraic geometry, at the level of *Ideals, Varieties and Algorithms* [35]. Each chapter begins with a background section that develops the necessary algebraic geometry.

Affine Toric Varieties

§1.0. Background: Affine Varieties

We begin with the algebraic geometry needed for our study of affine toric varieties. Our discussion assumes Chapters 1–5 and 9 of [35].

Coordinate Rings. An ideal $I \subseteq S = \mathbb{C}[x_1, \dots, x_n]$ gives an affine variety

$$\mathbf{V}(I) = \{p \in \mathbb{C}^n \mid f(p) = 0 \text{ for all } f \in I\}$$

and an affine variety $V \subseteq \mathbb{C}^n$ gives the ideal

$$\mathbf{I}(V) = \{f \in S \mid f(p) = 0 \text{ for all } p \in V\}.$$

By the Hilbert Basis Theorem, an affine variety V is defined by the vanishing of finitely many polynomials in S , and for any ideal I , the Nullstellensatz tells us that $\mathbf{I}(\mathbf{V}(I)) = \sqrt{I} = \{f \in S \mid f^\ell \in I \text{ for some } \ell \geq 1\}$ since \mathbb{C} is algebraically closed. The most important algebraic object associated to V is its *coordinate ring*

$$\mathbb{C}[V] = S/\mathbf{I}(V).$$

Elements of $\mathbb{C}[V]$ can be interpreted as the \mathbb{C} -valued polynomial functions on V . Note that $\mathbb{C}[V]$ is a \mathbb{C} -algebra, meaning that its vector space structure is compatible with its ring structure. Here are some basic facts about coordinate rings:

- $\mathbb{C}[V]$ is an integral domain $\Leftrightarrow \mathbf{I}(V)$ is a prime ideal $\Leftrightarrow V$ is irreducible.
- Polynomial maps (also called *morphisms*) $\phi : V_1 \rightarrow V_2$ between affine varieties correspond to \mathbb{C} -algebra homomorphisms $\phi^* : \mathbb{C}[V_2] \rightarrow \mathbb{C}[V_1]$, where $\phi^*(g) = g \circ \phi$ for $g \in \mathbb{C}[V_2]$.
- Two affine varieties are isomorphic if and only if their coordinate rings are isomorphic \mathbb{C} -algebras.

- A point p of an affine variety V gives the maximal ideal

$$\{f \in \mathbb{C}[V] \mid f(p) = 0\} \subseteq \mathbb{C}[V],$$

and all maximal ideals of $\mathbb{C}[V]$ arise this way.

Coordinate rings of affine varieties can be characterized as follows (Exercise 1.0.1).

Lemma 1.0.1. *A \mathbb{C} -algebra R is isomorphic to the coordinate ring of an affine variety if and only if R is a finitely generated \mathbb{C} -algebra with no nonzero nilpotents, i.e., if $f \in R$ satisfies $f^\ell = 0$ for some $\ell \geq 1$, then $f = 0$. \square*

To emphasize the close relation between V and $\mathbb{C}[V]$, we sometimes write

$$(1.0.1) \quad V = \text{Spec}(\mathbb{C}[V]).$$

This can be made canonical by identifying V with the set of maximal ideals of $\mathbb{C}[V]$ via the fourth bullet above. More generally, one can take any commutative ring R and define the *affine scheme* $\text{Spec}(R)$. The general definition of Spec uses all prime ideals of R , not just the maximal ideals as we have done. Thus some authors would write (1.0.1) as $V = \text{Specm}(\mathbb{C}[V])$, the maximal spectrum of $\mathbb{C}[V]$. Readers wishing to learn about affine schemes should consult [48] and [77].

The Zariski Topology. An affine variety $V \subseteq \mathbb{C}^n$ has two topologies we will use. The first is the *classical topology*, induced from the usual topology on \mathbb{C}^n . The second is the *Zariski topology*, where the Zariski closed sets are subvarieties of V (meaning affine varieties of \mathbb{C}^n contained in V) and the Zariski open sets are their complements. Since subvarieties are closed in the classical topology (polynomials are continuous), Zariski open subsets are open in the classical topology.

Given a subset $S \subseteq V$, its closure \bar{S} in the Zariski topology is the smallest subvariety of V containing S . We call \bar{S} the *Zariski closure* of S . It is easy to give examples where this differs from the closure in the classical topology.

Affine Open Subsets and Localization. Some Zariski open subsets of an affine variety V are themselves affine varieties. Given $f \in \mathbb{C}[V] \setminus \{0\}$, let

$$V_f = \{p \in V \mid f(p) \neq 0\} \subseteq V.$$

Then V_f is Zariski open in V and is also an affine variety, as we now explain.

Let $V \subseteq \mathbb{C}^n$ have $\mathbf{I}(V) = \langle f_1, \dots, f_s \rangle$ and pick $g \in \mathbb{C}[x_1, \dots, x_n]$ representing f . Then $V_f = V \setminus \mathbf{V}(g)$ is Zariski open in V . Now consider a new variable y and let $W = \mathbf{V}(f_1, \dots, f_s, 1 - gy) \subseteq \mathbb{C}^n \times \mathbb{C}$. Since the projection map $\mathbb{C}^n \times \mathbb{C} \rightarrow \mathbb{C}^n$ maps W bijectively onto V_f , we can identify V_f with the affine variety $W \subseteq \mathbb{C}^n \times \mathbb{C}$.

When V is irreducible, the coordinate ring of V_f is easy to describe. Let $\mathbb{C}(V)$ be the field of fractions of the integral domain $\mathbb{C}[V]$. Recall that elements of $\mathbb{C}(V)$ give rational functions on V . Then let

$$(1.0.2) \quad \mathbb{C}[V]_f = \{g/f^\ell \in \mathbb{C}(V) \mid g \in \mathbb{C}[V], \ell \geq 0\}.$$

In Exercise 1.0.3 you will prove that $\text{Spec}(\mathbb{C}[V]_f)$ is the affine variety V_f .

Example 1.0.2. The n -dimensional torus is the affine open subset

$$(\mathbb{C}^*)^n = \mathbb{C}^n \setminus \mathbf{V}(x_1 \cdots x_n) \subseteq \mathbb{C}^n,$$

with coordinate ring

$$\mathbb{C}[x_1, \dots, x_n]_{x_1 \cdots x_n} = \mathbb{C}[x_1^{\pm 1}, \dots, x_n^{\pm 1}].$$

Elements of this ring are called *Laurent polynomials*. ◇

The ring $\mathbb{C}[V]_f$ from (1.0.2) is an example of *localization*. In Exercises 1.0.2 and 1.0.3 you will show how to construct this ring for all affine varieties, not just irreducible ones. The general concept of localization is discussed in standard texts in commutative algebra such as [3, Ch. 3] and [47, Ch. 2].

Normal Affine Varieties. Let R be an integral domain with field of fractions K . Then R is *normal*, or *integrally closed*, if every element of K which is integral over R (meaning that it is a root of a monic polynomial in $R[x]$) actually lies in R . For example, any UFD is normal (Exercise 1.0.5).

Definition 1.0.3. An irreducible affine variety V is *normal* if its coordinate ring $\mathbb{C}[V]$ is normal.

For example, \mathbb{C}^n is normal since its coordinate ring $\mathbb{C}[x_1, \dots, x_n]$ is a UFD and hence normal. Here is an example of a non-normal affine variety.

Example 1.0.4. Let $C = \mathbf{V}(x^3 - y^2) \subseteq \mathbb{C}^2$. This is an irreducible plane curve with a cusp at the origin. It is easy to see that $\mathbb{C}[C] = \mathbb{C}[x, y]/\langle x^3 - y^2 \rangle$. Now let \bar{x} and \bar{y} be the cosets of x and y in $\mathbb{C}[C]$ respectively. This gives $\bar{y}/\bar{x} \in \mathbb{C}(C)$. A computation shows that $\bar{y}/\bar{x} \notin \mathbb{C}[C]$ and that $(\bar{y}/\bar{x})^2 = \bar{x}$. Consequently $\mathbb{C}[C]$ and hence C are not normal.

We will see below that C is an affine toric variety. ◇

An irreducible affine variety V has a *normalization* defined as follows. Let

$$\mathbb{C}[V]' = \{\alpha \in \mathbb{C}(V) : \alpha \text{ is integral over } \mathbb{C}[V]\}.$$

We call $\mathbb{C}[V]'$ the *integral closure* of $\mathbb{C}[V]$. One can show that $\mathbb{C}[V]'$ is normal and (with more work) finitely generated as a \mathbb{C} -algebra (see [47, Cor. 13.13]). This gives the normal affine variety

$$V' = \text{Spec}(\mathbb{C}[V]')$$

We call V' the *normalization* of V . The natural inclusion $\mathbb{C}[V] \subseteq \mathbb{C}[V]' = \mathbb{C}[V]'$ corresponds to a map $V' \rightarrow V$. This is the *normalization map*.

Example 1.0.5. We saw in Example 1.0.4 that the curve $C \subseteq \mathbb{C}^2$ defined by $x^3 = y^2$ has elements $\bar{x}, \bar{y} \in \mathbb{C}[C]$ such that $\bar{y}/\bar{x} \notin \mathbb{C}[C]$ is integral over $\mathbb{C}[C]$. In Exercise 1.0.6 you will show that $\mathbb{C}[\bar{y}/\bar{x}] \subseteq \mathbb{C}(C)$ is the integral closure of $\mathbb{C}[C]$ and that the normalization map is the map $\mathbb{C} \rightarrow C$ defined by $t \mapsto (t^2, t^3)$. \diamond

At first glance, the definition of normal does not seem very intuitive. Once we enter the world of toric varieties, however, we will see that normality has a very nice combinatorial interpretation and that the nicest toric varieties are the normal ones. We will also see that normality leads to a nice theory of divisors.

In Exercise 1.0.7 you will prove some properties of normal domains that will be used in §1.3 when we study normal affine toric varieties.

Smooth Points of Affine Varieties. In order to define a smooth point of an affine variety V , we first need to define *local rings* and *Zariski tangent spaces*. When V is irreducible, the *local ring* of V at p is

$$\mathcal{O}_{V,p} = \{f/g \in \mathbb{C}(V) \mid f, g \in \mathbb{C}[V] \text{ and } g(p) \neq 0\}.$$

Thus $\mathcal{O}_{V,p}$ consists of all rational functions on V that are defined at p . Inside of $\mathcal{O}_{V,p}$ we have the maximal ideal

$$\mathfrak{m}_{V,p} = \{\phi \in \mathcal{O}_{V,p} \mid \phi(p) = 0\}.$$

In fact, $\mathfrak{m}_{V,p}$ is the unique maximal ideal of $\mathcal{O}_{V,p}$, so that $\mathcal{O}_{V,p}$ is a *local ring*. Exercises 1.0.2 and 1.0.4 explain how to define $\mathcal{O}_{V,p}$ when V is not irreducible.

The *Zariski tangent space* of V at p is defined to be

$$T_p(V) = \text{Hom}_{\mathbb{C}}(\mathfrak{m}_{V,p}/\mathfrak{m}_{V,p}^2, \mathbb{C}).$$

In Exercise 1.0.8 you will verify that $\dim T_p(\mathbb{C}^n) = n$ for every $p \in \mathbb{C}^n$. According to [77, p. 32], we can compute the Zariski tangent space of a point in an affine variety as follows.

Lemma 1.0.6. *Let $V \subseteq \mathbb{C}^n$ be an affine variety and let $p \in V$. Also assume that $\mathbf{I}(V) = \langle f_1, \dots, f_s \rangle \subseteq \mathbb{C}[x_1, \dots, x_n]$. For each i , let*

$$d_p(f_i) = \frac{\partial f_i}{\partial x_1}(p)x_1 + \dots + \frac{\partial f_i}{\partial x_n}(p)x_n.$$

Then the Zariski tangent $T_p(V)$ is isomorphic to the subspace of \mathbb{C}^n defined by the equations $d_p(f_1) = \dots = d_p(f_s) = 0$. In particular, $\dim T_p(V) \leq n$. \square

Definition 1.0.7. A point p of an affine variety V is *smooth* or *nonsingular* if $\dim T_p(V) = \dim_p V$, where $\dim_p V$ is the maximum of the dimensions of the irreducible components of V containing p . The point p is *singular* if it is not smooth. Finally, V is *smooth* if every point of V is smooth.

Points lying in the intersection of two or more irreducible components of V are always singular ([35, Thm. 8 of Ch. 9, §6]).

Since $\dim T_p(\mathbb{C}^n) = n$ for every $p \in \mathbb{C}^n$, we see that \mathbb{C}^n is smooth. For an irreducible affine variety $V \subseteq \mathbb{C}^n$ of dimension d , fix $p \in V$ and write $\mathbf{I}(V) = \langle f_1, \dots, f_s \rangle$. Using Lemma 1.0.6, it is straightforward to show that V is smooth at p if and only if the Jacobian matrix

$$(1.0.3) \quad J_p(f_1, \dots, f_s) = \left(\frac{\partial f_i}{\partial x_j}(p) \right)_{1 \leq i \leq s, 1 \leq j \leq n}$$

has rank $n - d$ (Exercise 1.0.9). Here is a simple example.

Example 1.0.8. As noted in Example 1.0.4, the plane curve C defined by $x^3 = y^2$ has $\mathbf{I}(C) = \langle x^3 - y^2 \rangle \subseteq \mathbb{C}[x, y]$. A point $p = (a, b) \in C$ has Jacobian

$$J_p = (3a^2, -2b),$$

so the origin is the only singular point of C . ◇

Since $T_p(V) = \text{Hom}_{\mathbb{C}}(\mathfrak{m}_{V,p}/\mathfrak{m}_{V,p}^2, \mathbb{C})$, we see that V is smooth at p when $\dim V$ equals the dimension of $\mathfrak{m}_{V,p}/\mathfrak{m}_{V,p}^2$ as a vector space over $\mathcal{O}_{V,p}/\mathfrak{m}_{V,p}$. In terms of commutative algebra, this means that $p \in V$ is smooth if and only if $\mathcal{O}_{V,p}$ is a *regular local ring*. See [3, p. 123] or [47, 10.3].

We can relate smoothness and normality as follows.

Proposition 1.0.9. *A smooth irreducible affine variety V is normal.*

Proof. In §3.0 we will see that $\mathbb{C}[V] = \bigcap_{p \in V} \mathcal{O}_{V,p}$. By Exercise 1.0.7, $\mathbb{C}[V]$ is normal once we prove that $\mathcal{O}_{V,p}$ is normal for all $p \in V$. Hence it suffices to show that $\mathcal{O}_{V,p}$ is normal whenever p is smooth.

This follows from some powerful results in commutative algebra: $\mathcal{O}_{V,p}$ is a regular local ring when p is a smooth point of V (see above), and every regular local ring is a UFD (see [47, Thm. 19.19]). Then we are done since every UFD is normal. A direct proof that $\mathcal{O}_{V,p}$ is normal at a smooth point $p \in V$ is sketched in Exercise 1.0.10. □

The converse of Proposition 1.0.9 can fail. We will see in §1.3 that the affine variety $\mathbf{V}(xy - zw) \subseteq \mathbb{C}^4$ is normal, yet $\mathbf{V}(xy - zw)$ is singular at the origin.

Products of Affine Varieties. Given affine varieties V_1 and V_2 , there are several ways to show that the cartesian product $V_1 \times V_2$ is an affine variety. The most direct way is to proceed as follows. Let $V_1 \subseteq \mathbb{C}^m = \text{Spec}(\mathbb{C}[x_1, \dots, x_m])$ and $V_2 \subseteq \mathbb{C}^n = \text{Spec}(\mathbb{C}[y_1, \dots, y_n])$. Take $\mathbf{I}(V_1) = \langle f_1, \dots, f_s \rangle$ and $\mathbf{I}(V_2) = \langle g_1, \dots, g_t \rangle$. Since the f_i and g_j depend on separate sets of variables, it follows that

$$V_1 \times V_2 = \mathbf{V}(f_1, \dots, f_s, g_1, \dots, g_t) \subseteq \mathbb{C}^{m+n}$$

is an affine variety.

A fancier method is to use the mapping properties of the product. This will also give an intrinsic description of its coordinate ring. Given V_1 and V_2 as above, $V_1 \times V_2$ should be an affine variety with projections $\pi_i : V_1 \times V_2 \rightarrow V_i$ such that whenever we have a diagram

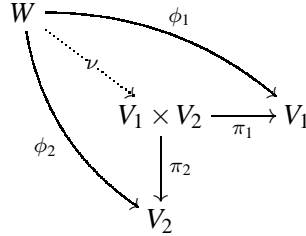

where $\phi_i : W \rightarrow V_i$ are morphisms from an affine variety W , there should be a unique morphism ν (the dotted arrow) that makes the diagram commute, i.e., $\pi_i \circ \nu = \phi_i$. For the coordinate rings, this means that whenever we have a diagram

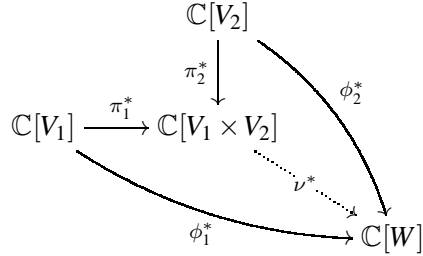

with \mathbb{C} -algebra homomorphisms $\phi_i^* : \mathbb{C}[V_i] \rightarrow \mathbb{C}[W]$, there should be a unique \mathbb{C} -algebra homomorphism ν^* (the dotted arrow) that makes the diagram commute. By the universal mapping property of the *tensor product* of \mathbb{C} -algebras, $\mathbb{C}[V_1] \otimes_{\mathbb{C}} \mathbb{C}[V_2]$ has the mapping properties we want. Since $\mathbb{C}[V_1] \otimes_{\mathbb{C}} \mathbb{C}[V_2]$ is a finitely generated \mathbb{C} -algebra with no nilpotents (see the appendix to this chapter), it is the coordinate ring $\mathbb{C}[V_1 \times V_2]$. For more on tensor products, see [3, pp. 24–27] or [47, A2.2].

Example 1.0.10. Let V be an affine variety. Since $\mathbb{C}^n = \text{Spec}(\mathbb{C}[y_1, \dots, y_n])$, the product $V \times \mathbb{C}^n$ has coordinate ring

$$\mathbb{C}[V] \otimes_{\mathbb{C}} \mathbb{C}[y_1, \dots, y_n] = \mathbb{C}[V][y_1, \dots, y_n].$$

If V is contained in \mathbb{C}^m with $\mathbf{I}(V) = \langle f_1, \dots, f_s \rangle \subseteq \mathbb{C}[x_1, \dots, x_m]$, it follows that

$$\mathbf{I}(V \times \mathbb{C}^n) = \langle f_1, \dots, f_s \rangle \subseteq \mathbb{C}[x_1, \dots, x_m, y_1, \dots, y_n].$$

For later purposes, we also note that the coordinate ring of $V \times (\mathbb{C}^*)^n$ is

$$\mathbb{C}[V] \otimes_{\mathbb{C}} \mathbb{C}[y_1^{\pm 1}, \dots, y_n^{\pm 1}] = \mathbb{C}[V][y_1^{\pm 1}, \dots, y_n^{\pm 1}]. \quad \diamond$$

Given affine varieties V_1 and V_2 , we note that the Zariski topology on $V_1 \times V_2$ is usually *not* the product of the Zariski topologies on V_1 and V_2 .

Example 1.0.11. Consider $\mathbb{C}^2 = \mathbb{C} \times \mathbb{C}$. By definition, a basis for the product of the Zariski topologies consists of sets $U_1 \times U_2$ where U_i are Zariski open in \mathbb{C} . Such a set is the complement of a union of collections of “horizontal” and “vertical” lines in \mathbb{C}^2 . This makes it easy to see that Zariski closed sets in \mathbb{C}^2 such as $\mathbf{V}(y - x^2)$ cannot be closed in the product topology. \diamond

Exercises for §1.0.

1.0.1. Prove Lemma 1.0.1. Hint: You will need the Nullstellensatz.

1.0.2. Let R be a commutative \mathbb{C} -algebra. A subset $S \subseteq R$ is a *multiplicative subset* provided $1 \in S$, $0 \notin S$, and S is closed under multiplication. The *localization* R_S consists of all formal expressions g/s , $g \in R$, $s \in S$, modulo the equivalence relation

$$g/s \sim h/t \iff u(tg - sh) = 0 \text{ for some } u \in S.$$

- Show that the usual formulas for adding and multiplying fractions induce well-defined binary operations that make R_S into \mathbb{C} -algebra.
- If R has no nonzero nilpotents, then prove that the same is true for R_S .

For more on localization, see [3, Ch. 3] or [47, Ch. 2].

1.0.3. Let R be a finitely generated \mathbb{C} -algebra without nilpotents as in Lemma 1.0.1 and let $f \in R$ be nonzero. Then $S = \{1, f, f^2, \dots\}$ is a multiplicative set. The localization R_S is denoted R_f and is called the *localization of R at f* .

- Show that R_f is a finitely generated \mathbb{C} -algebra without nilpotents.
- Show that R_f satisfies $\text{Spec}(R_f) = \text{Spec}(R)_f$.
- Show that R_f is given by (1.0.2) when R is an integral domain.

1.0.4. Let V be an affine variety with coordinate ring $\mathbb{C}[V]$. Given a point $p \in V$, let $S = \{g \in \mathbb{C}[V] \mid g(p) \neq 0\}$.

- Show that S is a multiplicative set. The localization $\mathbb{C}[V]_S$ is denoted $\mathcal{O}_{V,p}$ and is called the *local ring of V at p* .
- Show that every $\phi \in \mathcal{O}_{V,p}$ has a well-defined value $\phi(p)$ and that

$$\mathfrak{m}_{V,p} = \{\phi \in \mathcal{O}_{V,p} \mid \phi(p) = 0\}$$

is the unique maximal ideal of $\mathcal{O}_{V,p}$.

- When V is irreducible, show that $\mathcal{O}_{V,p}$ agrees with the definition given in the text.

1.0.5. Prove that a UFD is normal.

1.0.6. In the setting of Example 1.0.5, show that $\mathbb{C}[\bar{y}/\bar{x}] \subseteq \mathbb{C}(C)$ is the integral closure of $\mathbb{C}[C]$ and that the normalization $\mathbb{C} \rightarrow C$ is defined by $t \mapsto (t^2, t^3)$.

1.0.7. In this exercise, you will prove some properties of normal domains needed for §1.3.

- Let R be a normal domain with field of fractions K and let $S \subseteq R$ be a multiplicative subset. Prove that the localization R_S is normal.
- Let R_α , $\alpha \in A$, be normal domains with the same field of fractions K . Prove that the intersection $\bigcap_{\alpha \in A} R_\alpha$ is normal.

1.0.8. Prove that $\dim T_p(\mathbb{C}^n) = n$ for all $p \in \mathbb{C}^n$.

1.0.9. Use Lemma 1.0.6 to prove the claim made in the text that smoothness is determined by the rank of the Jacobian matrix (1.0.3).

1.0.10. Let V be irreducible and suppose that $p \in V$ is smooth. The goal of this exercise is to prove that $\mathcal{O}_{V,p}$ is normal using standard results from commutative algebra. Set $n = \dim V$ and consider the ring of formal power series $\mathbb{C}[[x_1, \dots, x_n]]$. This is a local ring with maximal ideal $\mathfrak{m} = \langle x_1, \dots, x_n \rangle$. We will use three facts:

- $\mathbb{C}[[x_1, \dots, x_n]]$ is a UFD by [174, p. 148] and hence normal by Exercise 1.0.5.
- Since $p \in V$ is smooth, [125, §1C] proves the existence of a \mathbb{C} -algebra homomorphism $\mathcal{O}_{V,p} \rightarrow \mathbb{C}[[x_1, \dots, x_n]]$ that induces isomorphisms

$$\mathcal{O}_{V,p}/\mathfrak{m}_{V,p}^\ell \simeq \mathbb{C}[[x_1, \dots, x_n]]/\mathfrak{m}^\ell$$

for all $\ell \geq 0$. This implies that the completion [3, Ch. 10]

$$\widehat{\mathcal{O}}_{V,p} = \varprojlim \mathcal{O}_{V,p}/\mathfrak{m}_{V,p}^\ell$$

is isomorphic to a formal power series ring, i.e., $\widehat{\mathcal{O}}_{V,p} \simeq \mathbb{C}[[x_1, \dots, x_n]]$. Such an isomorphism captures the intuitive idea that at a smooth point, functions should have power series expansions in “local coordinates” x_1, \dots, x_n .

- If $I \subseteq \mathcal{O}_{V,p}$ is an ideal, then

$$I = \bigcap_{\ell=1}^{\infty} (I + \mathfrak{m}_{V,p}^\ell).$$

This theorem of Krull holds for any ideal I in a Noetherian local ring A and follows from [3, Cor. 10.19] with $M = A/I$.

Now assume that $p \in V$ is smooth.

- Use the third bullet to show that $\mathcal{O}_{V,p} \rightarrow \mathbb{C}[[x_1, \dots, x_n]]$ is injective.
- Suppose that $a, b \in \mathcal{O}_{V,p}$ satisfy $b|a$ in $\mathbb{C}[[x_1, \dots, x_n]]$. Prove that $b|a$ in $\mathcal{O}_{V,p}$. Hint: Use the second bullet to show $a \in b\mathcal{O}_{V,p} + \mathfrak{m}_{V,p}^\ell$ and then use the third bullet.
- Prove that $\mathcal{O}_{V,p}$ is normal. Hint: Use part (b) and the first bullet.

This argument can be continued to show that $\mathcal{O}_{V,p}$ is a UFD. See [125, (1.28)]

1.0.11. Let V and W be affine varieties and let $S \subseteq V$ be a subset. Prove that $\overline{S} \times W = \overline{S \times W}$.

1.0.12. Let V and W be irreducible affine varieties. Prove that $V \times W$ is irreducible. Hint: Suppose $V \times W = Z_1 \cup Z_2$, where Z_1, Z_2 are closed. Let $V_i = \{v \in V \mid \{v\} \times W \subseteq Z_i\}$. Prove that $V = V_1 \cup V_2$ and that V_i is closed in V . Exercise 1.0.11 will be useful.

§1.1. Introduction to Affine Toric Varieties

We first discuss what we mean by “torus” and then explore various constructions of affine toric varieties.

The Torus. The affine variety $(\mathbb{C}^*)^n$ is a group under component-wise multiplication. A torus T is an affine variety isomorphic to $(\mathbb{C}^*)^n$, where T inherits a group structure from the isomorphism. Associated to T are its *characters* and *one-parameter subgroups*. We discuss each of these briefly.

A *character* of a torus T is a morphism $\chi : T \rightarrow \mathbb{C}^*$ that is a group homomorphism. For example, $m = (a_1, \dots, a_n) \in \mathbb{Z}^n$ gives a character $\chi^m : (\mathbb{C}^*)^n \rightarrow \mathbb{C}^*$ defined by

$$(1.1.1) \quad \chi^m(t_1, \dots, t_n) = t_1^{a_1} \cdots t_n^{a_n}.$$

One can show that *all* characters of $(\mathbb{C}^*)^n$ arise this way (see [92, §16]). Thus the characters of $(\mathbb{C}^*)^n$ form a group isomorphic to \mathbb{Z}^n .

For an arbitrary torus T , its characters form a free abelian group M of rank equal to the dimension of T . It is customary to say that $m \in M$ gives the character $\chi^m : T \rightarrow \mathbb{C}^*$.

We will need the following results concerning tori (see [92, §16] for proofs).

Proposition 1.1.1.

- (a) Let T_1 and T_2 be tori and let $\Phi : T_1 \rightarrow T_2$ be a morphism that is a group homomorphism. Then the image of Φ is a torus and is closed in T_2 .
- (b) Let T be a torus and let $H \subseteq T$ be an irreducible subvariety of T that is a subgroup. Then H is a torus. \square

Now assume that a torus T acts linearly on a finite dimensional vector space W over \mathbb{C} , where the action of $t \in T$ on $w \in W$ is denoted $t \cdot w$. Given $m \in M$, we get the *eigenspace*

$$W_m = \{w \in W \mid t \cdot w = \chi^m(t)w \text{ for all } t \in T\}.$$

If $W_m \neq \{0\}$, then every $w \in W_m \setminus \{0\}$ is a simultaneous eigenvector for all $t \in T$, with eigenvalue given by $\chi^m(t)$.

Proposition 1.1.2. *In the above situation, we have $W = \bigoplus_{m \in M} W_m$.* \square

This proposition is a sophisticated way of saying that a family of commuting diagonalizable linear maps can be simultaneously diagonalized.

A *one-parameter subgroup* of a torus T is a morphism $\lambda : \mathbb{C}^* \rightarrow T$ that is a group homomorphism. For example, $u = (b_1, \dots, b_n) \in \mathbb{Z}^n$ gives a one-parameter subgroup $\lambda^u : \mathbb{C}^* \rightarrow (\mathbb{C}^*)^n$ defined by

$$(1.1.2) \quad \lambda^u(t) = (t^{b_1}, \dots, t^{b_n}).$$

All one-parameter subgroups of $(\mathbb{C}^*)^n$ arise this way (see [92, §16]). It follows that the group of one-parameter subgroups of $(\mathbb{C}^*)^n$ is naturally isomorphic to \mathbb{Z}^n . For an arbitrary torus T , the one-parameter subgroups form a free abelian group N of rank equal to the dimension of T . As with the character group, an element $u \in N$ gives the one-parameter subgroup $\lambda^u : \mathbb{C}^* \rightarrow T$.

There is a natural bilinear pairing $\langle \cdot, \cdot \rangle : M \times N \rightarrow \mathbb{Z}$ defined as follows.

- (Intrinsic) Given a character χ^m and a one-parameter subgroup λ^u , the composition $\chi^m \circ \lambda^u : \mathbb{C}^* \rightarrow \mathbb{C}^*$ is character of \mathbb{C}^* , which is given by $t \mapsto t^\ell$ for some $\ell \in \mathbb{Z}$. Then $\langle m, u \rangle = \ell$.

- (Concrete) If $T = (\mathbb{C}^*)^n$ with $m = (a_1, \dots, a_n) \in \mathbb{Z}^n$, $u = (b_1, \dots, b_n) \in \mathbb{Z}^n$, then one computes that

$$(1.1.3) \quad \langle m, u \rangle = \sum_{i=1}^n a_i b_i,$$

i.e., the pairing is the usual dot product.

It follows that the characters and one-parameter subgroups of a torus T form free abelian groups M and N of finite rank with a pairing $\langle \cdot, \cdot \rangle : M \times N \rightarrow \mathbb{Z}$ that identifies N with $\text{Hom}_{\mathbb{Z}}(M, \mathbb{Z})$ and M with $\text{Hom}_{\mathbb{Z}}(N, \mathbb{Z})$. In terms of tensor products, one obtains a canonical isomorphism $N \otimes_{\mathbb{Z}} \mathbb{C}^* \simeq T$ via $u \otimes t \mapsto \lambda^u(t)$. Hence it is customary to write a torus as T_N .

From this point of view, picking an isomorphism $T_N \simeq (\mathbb{C}^*)^n$ induces dual bases of M and N , i.e., isomorphisms $M \simeq \mathbb{Z}^n$ and $N \simeq \mathbb{Z}^n$ that turn characters into Laurent monomials (1.1.1), one-parameter subgroups into monomial curves (1.1.2), and the pairing into dot product (1.1.3).

The Definition of Affine Toric Variety. We now define the main object of study of this chapter.

Definition 1.1.3. An *affine toric variety* is an irreducible affine variety V containing a torus $T_N \simeq (\mathbb{C}^*)^n$ as a Zariski open subset such that the action of T_N on itself extends to an algebraic action of T_N on V . (By algebraic action, we mean an action $T_N \times V \rightarrow V$ given by a morphism.)

Obvious examples of affine toric varieties are $(\mathbb{C}^*)^n$ and \mathbb{C}^n . Here are some less trivial examples.

Example 1.1.4. The plane curve $C = \mathbf{V}(x^3 - y^2) \subseteq \mathbb{C}^2$ has a cusp at the origin. This is an affine toric variety with torus

$$C - \{0\} = C \cap (\mathbb{C}^*)^2 = \{(t^2, t^3) \mid t \in \mathbb{C}^*\} \simeq \mathbb{C}^*,$$

where the isomorphism is $t \mapsto (t^2, t^3)$. Example 1.0.4 shows that C is a non-normal toric variety. \diamond

Example 1.1.5. The variety $V = \mathbf{V}(xy - zw) \subseteq \mathbb{C}^4$ is a toric variety with torus

$$V \cap (\mathbb{C}^*)^4 = \{(t_1, t_2, t_3, t_1 t_2 t_3^{-1}) \mid t_i \in \mathbb{C}^*\} \simeq (\mathbb{C}^*)^3,$$

where the isomorphism is $(t_1, t_2, t_3) \mapsto (t_1, t_2, t_3, t_1 t_2 t_3^{-1})$. We will see later that V is normal. \diamond

Example 1.1.6. Consider the surface in \mathbb{C}^{d+1} parametrized by the map

$$\Phi : \mathbb{C}^2 \longrightarrow \mathbb{C}^{d+1}$$

defined by $(s, t) \mapsto (s^d, s^{d-1}t, \dots, st^{d-1}, t^d)$. Thus Φ is defined using all degree d monomials in s, t .

Let the coordinates of \mathbb{C}^{d+1} be x_0, \dots, x_d and let $I \subseteq \mathbb{C}[x_0, \dots, x_d]$ be the ideal generated by the 2×2 minors of the matrix

$$\begin{pmatrix} x_0 & x_1 & \cdots & x_{d-2} & x_{d-1} \\ x_1 & x_2 & \cdots & x_{d-1} & x_d \end{pmatrix},$$

so $I = \langle x_i x_{j+1} - x_{i+1} x_j \mid 0 \leq i < j \leq d-1 \rangle$. In Exercise 1.1.1 you will verify that $\Phi(\mathbb{C}^2) = \mathbf{V}(I)$, so that $\widehat{C}_d = \Phi(\mathbb{C}^2)$ is an affine variety. You will also prove that $\mathbf{I}(\widehat{C}_d) = I$, so that I is the ideal of all polynomials vanishing on \widehat{C}_d . It follows that I is prime since $\mathbf{V}(I)$ is irreducible by Proposition 1.1.8 below. The affine surface \widehat{C}_d is called the *rational normal cone of degree d* and is an example of a *determinantal variety*. We will see below that I is a toric ideal.

It is straightforward to show that \widehat{C}_d is a toric variety with torus

$$\Phi((\mathbb{C}^*)^2) = \widehat{C}_d \cap (\mathbb{C}^*)^{d+1} \simeq (\mathbb{C}^*)^2.$$

We will study this example from the projective point of view in Chapter 2. \diamond

We next explore three equivalent ways of constructing affine toric varieties.

Lattice Points. In this book, a *lattice* is a free abelian group of finite rank. Thus a lattice of rank n is isomorphic to \mathbb{Z}^n . For example, a torus T_N has lattices M (of characters) and N (of one-parameter subgroups).

Given a torus T_N with character lattice M , a set $\mathcal{A} = \{m_1, \dots, m_s\} \subseteq M$ gives characters $\chi^{m_i} : T_N \rightarrow \mathbb{C}^*$. Then consider the map

$$(1.1.4) \quad \Phi_{\mathcal{A}} : T_N \longrightarrow \mathbb{C}^s$$

defined by

$$\Phi_{\mathcal{A}}(t) = (\chi^{m_1}(t), \dots, \chi^{m_s}(t)) \in \mathbb{C}^s.$$

Definition 1.1.7. Given a finite set $\mathcal{A} \subseteq M$, the affine toric variety $Y_{\mathcal{A}}$ is defined to be the Zariski closure of the image of the map $\Phi_{\mathcal{A}}$ from (1.1.4).

This definition is justified by the following proposition.

Proposition 1.1.8. Given $\mathcal{A} \subseteq M$ as above, let $\mathbb{Z}\mathcal{A} \subseteq M$ be the sublattice generated by \mathcal{A} . Then $Y_{\mathcal{A}}$ is an affine toric variety whose torus has character lattice $\mathbb{Z}\mathcal{A}$. In particular, the dimension of $Y_{\mathcal{A}}$ is the rank of $\mathbb{Z}\mathcal{A}$.

Proof. The map (1.1.4) can be regarded as a map

$$\Phi_{\mathcal{A}} : T_N \longrightarrow (\mathbb{C}^*)^s$$

of tori. By Proposition 1.1.1, the image $T = \Phi_{\mathcal{A}}(T_N)$ is a torus that is closed in $(\mathbb{C}^*)^s$. The latter implies that $Y_{\mathcal{A}} \cap (\mathbb{C}^*)^s = T$ since $Y_{\mathcal{A}}$ is the Zariski closure of the image. It follows that the image is Zariski open in $Y_{\mathcal{A}}$. Furthermore, T is irreducible (it is a torus), so the same is true for its Zariski closure $Y_{\mathcal{A}}$.

We next consider the action of T . Since $T \subseteq (\mathbb{C}^*)^s$, an element $t \in T$ acts on \mathbb{C}^s and takes varieties to varieties. Then

$$T = t \cdot T \subseteq t \cdot Y_{\mathcal{A}}$$

shows that $t \cdot Y_{\mathcal{A}}$ is a variety containing T . Hence $Y_{\mathcal{A}} \subseteq t \cdot Y_{\mathcal{A}}$ by the definition of Zariski closure. Replacing t with t^{-1} leads to $Y_{\mathcal{A}} = t \cdot Y_{\mathcal{A}}$, so that the action of T induces an action on $Y_{\mathcal{A}}$. We conclude that $Y_{\mathcal{A}}$ is an affine toric variety.

It remains to compute the character lattice of T , which we will temporarily denote by M' . Since $T = \Phi_{\mathcal{A}}(T_N)$, the map $\Phi_{\mathcal{A}}$ gives the commutative diagram

$$\begin{array}{ccc} T_N & \xrightarrow{\Phi_{\mathcal{A}}} & (\mathbb{C}^*)^s \\ & \searrow & \uparrow \\ & & T \end{array}$$

where \rightarrow denotes a surjective map and \hookrightarrow an injective map. This diagram of tori induces a commutative diagram of character lattices

$$\begin{array}{ccc} M & \xleftarrow{\widehat{\Phi}_{\mathcal{A}}} & \mathbb{Z}^s \\ & \searrow & \downarrow \\ & & M' \end{array}$$

Since $\widehat{\Phi}_{\mathcal{A}} : \mathbb{Z}^s \rightarrow M$ takes the standard basis e_1, \dots, e_s to m_1, \dots, m_s , the image of $\widehat{\Phi}_{\mathcal{A}}$ is $\mathbb{Z}\mathcal{A}$. By the diagram, we obtain $M' \simeq \mathbb{Z}\mathcal{A}$. Then we are done since the dimension of a torus equals the rank of its character lattice. \square

In concrete terms, fix a basis of M , so that we may assume $M = \mathbb{Z}^n$. Then the s vectors in $\mathcal{A} \subseteq \mathbb{Z}^n$ can be regarded as the columns of an $n \times s$ matrix A with integer entries. In this case, the dimension of $Y_{\mathcal{A}}$ is simply the rank of the matrix A .

We will see below that every affine toric variety is isomorphic to $Y_{\mathcal{A}}$ for some finite subset \mathcal{A} of a lattice.

Toric Ideals. Let $Y_{\mathcal{A}} \subseteq \mathbb{C}^s = \text{Spec}(\mathbb{C}[x_1, \dots, x_s])$ be the affine toric variety coming from a finite set $\mathcal{A} = \{m_1, \dots, m_s\} \subseteq M$. We can describe the ideal $\mathbf{I}(Y_{\mathcal{A}}) \subseteq \mathbb{C}[x_1, \dots, x_s]$ as follows. As in the proof of Proposition 1.1.8, $\Phi_{\mathcal{A}}$ induces a map of character lattices

$$\widehat{\Phi}_{\mathcal{A}} : \mathbb{Z}^s \longrightarrow M$$

that sends the standard basis e_1, \dots, e_s to m_1, \dots, m_s . Let L be the kernel of this map, so that we have an exact sequence

$$0 \longrightarrow L \longrightarrow \mathbb{Z}^s \longrightarrow M.$$

In down to earth terms, elements $\ell = (\ell_1, \dots, \ell_s)$ of L satisfy $\sum_{i=1}^s \ell_i m_i = 0$ and hence record the linear relations among the m_i .

Given $\ell = (\ell_1, \dots, \ell_s) \in L$, set

$$\ell_+ = \sum_{\ell_i > 0} \ell_i e_i \quad \text{and} \quad \ell_- = - \sum_{\ell_i < 0} \ell_i e_i.$$

Note that $\ell = \ell_+ - \ell_-$ and that $\ell_+, \ell_- \in \mathbb{N}^s$. It follows easily that the binomial

$$x^{\ell_+} - x^{\ell_-} = \prod_{\ell_i > 0} x_i^{\ell_i} - \prod_{\ell_i < 0} x_i^{-\ell_i}$$

vanishes on the image of $\Phi_{\mathcal{A}}$ and hence on $Y_{\mathcal{A}}$ since $Y_{\mathcal{A}}$ is the Zariski closure of the image.

Proposition 1.1.9. *The ideal of the affine toric variety $Y_{\mathcal{A}} \subseteq \mathbb{C}^s$ is*

$$\mathbf{I}(Y_{\mathcal{A}}) = \langle x^{\ell_+} - x^{\ell_-} \mid \ell \in L \rangle = \langle x^\alpha - x^\beta \mid \alpha, \beta \in \mathbb{N}^s \text{ and } \alpha - \beta \in L \rangle.$$

Proof. We leave it to the reader to prove equality of the two ideals on the right (Exercise 1.1.2). Let I_L denote this ideal and note that $I_L \subseteq \mathbf{I}(Y_{\mathcal{A}})$. We prove the opposite inclusion following [166, Lem. 4.1]. Pick a monomial order $>$ on $\mathbb{C}[x_1, \dots, x_s]$ and an isomorphism $T_N \simeq (\mathbb{C}^*)^n$. Thus we may assume $M = \mathbb{Z}^n$ and the map $\Phi : (\mathbb{C}^*)^n \rightarrow \mathbb{C}^s$ is given by Laurent monomials t^{m_i} in variables t_1, \dots, t_n . If $I_L \neq \mathbf{I}(Y_{\mathcal{A}})$, then we can pick $f \in \mathbf{I}(Y_{\mathcal{A}}) \setminus I_L$ with minimal leading monomial $x^\alpha = \prod_{i=1}^s x_i^{\alpha_i}$. Rescaling if necessary, x^α becomes the leading term of f .

Since $f(t^{m_1}, \dots, t^{m_s})$ is identically zero as a polynomial in t_1, \dots, t_n , there must be cancellation involving the term coming from x^α . In other words, f must contain a monomial $x^\beta = \prod_{i=1}^s x_i^{\beta_i} < x^\alpha$ such that

$$\prod_{i=1}^s (t^{m_i})^{a_i} = \prod_{i=1}^s (t^{m_i})^{b_i}.$$

This implies that

$$\sum_{i=1}^s a_i m_i = \sum_{i=1}^s b_i m_i,$$

so that $\alpha - \beta = \sum_{i=1}^s (a_i - b_i) e_i \in L$. Then $x^\alpha - x^\beta \in I_L$ by the second description of I_L . It follows that $f - x^\alpha + x^\beta$ also lies in $\mathbf{I}(Y_{\mathcal{A}}) \setminus I_L$ and has strictly smaller leading term. This contradiction completes the proof. \square

Given a finite set $\mathcal{A} \subseteq M$, there are several methods to compute the ideal $\mathbf{I}(Y_{\mathcal{A}}) = I_L$ of Proposition 1.1.9. For simple examples, the rational implicitization algorithm of [35, Ch. 3, §3] can be used. It is also possible to compute I_L using a basis of L and ideal quotients (Exercise 1.1.3). Further comments on computing I_L can be found in [166, Ch. 12].

Inspired by Proposition 1.1.9, we make the following definition.

Definition 1.1.10. Let $L \subseteq \mathbb{Z}^s$ be a sublattice.

- (a) The ideal $I_L = \langle x^\alpha - x^\beta \mid \alpha, \beta \in \mathbb{N}^s \text{ and } \alpha - \beta \in L \rangle$ is called a *lattice ideal*.
- (b) A prime lattice ideal is called a *toric ideal*.

Since toric varieties are irreducible, the ideals appearing in Proposition 1.1.9 are toric ideals. Examples of toric ideals include:

$$\text{Example 1.1.4 : } \langle x^3 - y^2 \rangle \subseteq \mathbb{C}[x, y]$$

$$\text{Example 1.1.5 : } \langle xz - yw \rangle \subseteq \mathbb{C}[x, y, z, w]$$

$$\text{Example 1.1.6 : } \langle x_i x_{j+1} - x_{i+1} x_j \mid 0 \leq i < j \leq d-1 \rangle \subseteq \mathbb{C}[x_0, \dots, x_d].$$

(The latter is the ideal of the rational normal cone $\widehat{C}_d \subseteq \mathbb{C}^{d+1}$.) In each example, we have a prime ideal generated by binomials. As we now show, such ideals are automatically toric.

Proposition 1.1.11. *An ideal $I \subseteq \mathbb{C}[x_1, \dots, x_s]$ is toric if and only if it is prime and generated by binomials.*

Proof. One direction is obvious. So suppose that I is prime and generated by binomials $x^{\alpha_i} - x^{\beta_i}$. Then observe that $\mathbf{V}(I) \cap (\mathbb{C}^*)^s$ is nonempty (it contains $(1, \dots, 1)$) and is a subgroup of $(\mathbb{C}^*)^s$ (easy to check). Since $\mathbf{V}(I) \subseteq \mathbb{C}^s$ is irreducible, it follows that $\mathbf{V}(I) \cap (\mathbb{C}^*)^s$ is an irreducible subvariety of $(\mathbb{C}^*)^s$ that is also a subgroup. By Proposition 1.1.1, we see that $T = \mathbf{V}(I) \cap (\mathbb{C}^*)^s$ is a torus.

Projecting on the i th coordinate of $(\mathbb{C}^*)^s$ gives a character $T \hookrightarrow (\mathbb{C}^*)^s \rightarrow \mathbb{C}^*$, which by our usual convention we write as $\chi^{m_i} : T \rightarrow \mathbb{C}^*$ for $m_i \in M$. It follows easily that $\mathbf{V}(I) = Y_{\mathcal{A}}$ for $\mathcal{A} = \{m_1, \dots, m_s\}$, and since I is prime, we have $I = \mathbf{I}(Y_{\mathcal{A}})$ by the Nullstellensatz. Then I is toric by Proposition 1.1.9. \square

We will later see that all affine toric varieties arise from toric ideals. For more on toric ideals and lattice ideals, the reader should consult [123, Ch. 7].

Affine Semigroups. A *semigroup* is a set S with an associative binary operation and an identity element. To be an *affine semigroup*, we further require that:

- The binary operation on S is commutative. We will write the operation as $+$ and the identity element as 0 . Thus a finite set $\mathcal{A} \subseteq S$ gives

$$\mathbb{N}\mathcal{A} = \left\{ \sum_{m \in \mathcal{A}} a_m m \mid a_m \in \mathbb{N} \right\} \subseteq S.$$

- The semigroup is finitely generated, meaning that there is a finite set $\mathcal{A} \subseteq S$ such that $\mathbb{N}\mathcal{A} = S$.
- The semigroup can be embedded in a lattice M .

The simplest example of an affine semigroup is $\mathbb{N}^n \subseteq \mathbb{Z}^n$. More generally, given a lattice M and a finite set $\mathcal{A} \subseteq M$, we get the affine semigroup $\mathbb{N}\mathcal{A} \subseteq M$. Up to isomorphism, all affine semigroups are of this form.

Given an affine semigroup $S \subseteq M$, the *semigroup algebra* $\mathbb{C}[S]$ is the vector space over \mathbb{C} with S as basis and multiplication induced by the semigroup structure of S . To make this precise, we think of M as the character lattice of a torus T_N , so that $m \in M$ gives the character χ^m . Then

$$\mathbb{C}[S] = \left\{ \sum_{m \in S} c_m \chi^m \mid c_m \in \mathbb{C} \text{ and } c_m = 0 \text{ for all but finitely many } m \right\},$$

with multiplication induced by

$$\chi^m \cdot \chi^{m'} = \chi^{m+m'}.$$

If $S = \mathbb{N}\mathcal{A}$ for $\mathcal{A} = \{m_1, \dots, m_s\}$, then $\mathbb{C}[S] = \mathbb{C}[\chi^{m_1}, \dots, \chi^{m_s}]$.

Here are two basic examples.

Example 1.1.12. The affine semigroup $\mathbb{N}^n \subseteq \mathbb{Z}^n$ gives the polynomial ring

$$\mathbb{C}[\mathbb{N}^n] = \mathbb{C}[x_1, \dots, x_n],$$

where $x_i = \chi^{e_i}$ and e_1, \dots, e_n is the standard basis of \mathbb{Z}^n . ◇

Example 1.1.13. If e_1, \dots, e_n is a basis of a lattice M , then M is generated by $\mathcal{A} = \{\pm e_1, \dots, \pm e_n\}$ as an affine semigroup. Setting $t_i = \chi^{e_i}$ gives the Laurent polynomial ring

$$\mathbb{C}[M] = \mathbb{C}[t_1^{\pm 1}, \dots, t_n^{\pm 1}].$$

Using Example 1.0.2, one sees that $\mathbb{C}[M]$ is the coordinate ring of the torus T_N . ◇

Affine semigroup rings give rise to affine toric varieties as follows.

Proposition 1.1.14. *Let $S \subseteq M$ be an affine semigroup.*

- (a) $\mathbb{C}[S]$ is an integral domain and finitely generated as a \mathbb{C} -algebra.
- (b) $\text{Spec}(\mathbb{C}[S])$ is an affine toric variety whose torus has character lattice $\mathbb{Z}S$, and if $S = \mathbb{N}\mathcal{A}$ for a finite set $\mathcal{A} \subseteq M$, then $\text{Spec}(\mathbb{C}[S]) = Y_{\mathcal{A}}$.

Proof. As noted above, $\mathcal{A} = \{m_1, \dots, m_s\}$ implies $\mathbb{C}[S] = \mathbb{C}[\chi^{m_1}, \dots, \chi^{m_s}]$, so $\mathbb{C}[S]$ is finitely generated. Since $\mathbb{C}[S] \subseteq \mathbb{C}[M]$ follows from $S \subseteq M$, we see that $\mathbb{C}[S]$ is an integral domain by Example 1.1.13.

Using $\mathcal{A} = \{m_1, \dots, m_s\}$, we get the \mathbb{C} -algebra homomorphism

$$\pi : \mathbb{C}[x_1, \dots, x_s] \longrightarrow \mathbb{C}[M]$$

where $x_i \mapsto \chi^{m_i} \in \mathbb{C}[M]$. This corresponds to the morphism

$$\Phi_{\mathcal{A}} : T_N \longrightarrow \mathbb{C}^s$$

from (1.1.4), i.e., $\pi = (\Phi_{\mathcal{A}})^*$ in the notation of §1.0. One checks that the kernel of π is the toric ideal $\mathbf{I}(Y_{\mathcal{A}})$ (Exercise 1.1.4). The image of π is $\mathbb{C}[\chi^{m_1}, \dots, \chi^{m_s}] = \mathbb{C}[S]$, and then the coordinate ring of $Y_{\mathcal{A}}$ is

$$(1.1.5) \quad \begin{aligned} \mathbb{C}[Y_{\mathcal{A}}] &= \mathbb{C}[x_1, \dots, x_s] / \mathbf{I}(Y_{\mathcal{A}}) \\ &= \mathbb{C}[x_1, \dots, x_s] / \text{Ker}(\pi) \simeq \text{Im}(\pi) = \mathbb{C}[S]. \end{aligned}$$

This proves that $\text{Spec}(\mathbb{C}[S]) = Y_{\mathcal{A}}$. Since $S = \mathbb{N}\mathcal{A}$ implies $\mathbb{Z}S = \mathbb{Z}\mathcal{A}$, the torus of $Y_{\mathcal{A}} = \text{Spec}(\mathbb{C}[S])$ has the desired character lattice by Proposition 1.1.8. \square

Here is an example of this proposition.

Example 1.1.15. Consider the affine semigroup $S \subseteq \mathbb{Z}$ generated by 2 and 3, so that $S = \{0, 2, 3, \dots\}$. To study the semigroup algebra $\mathbb{C}[S]$, we use (1.1.5). If we set $\mathcal{A} = \{2, 3\}$, then $\Phi_{\mathcal{A}}(t) = (t^2, t^3)$ and the toric ideal is $\mathbf{I}(Y_{\mathcal{A}}) = \langle x^3 - y^2 \rangle$ by Example 1.1.4. Hence

$$\mathbb{C}[S] = \mathbb{C}[t^2, t^3] \simeq \mathbb{C}[x, y] / \langle x^3 - y^2 \rangle$$

and the affine toric variety $Y_{\mathcal{A}}$ is the curve $x^3 = y^2$. \diamond

Equivalence of Constructions. Before stating our main result, we need to study the action of the torus T_N on the semigroup algebra $\mathbb{C}[M]$. The action of T_N on itself given by multiplication induces an action on $\mathbb{C}[M]$ as follows: if $t \in T_N$ and $f \in \mathbb{C}[M]$, then $t \cdot f \in \mathbb{C}[M]$ is defined by $p \mapsto f(t^{-1} \cdot p)$ for $p \in V$. The minus sign will be explained in §5.0.

The following lemma will be used several times in the text.

Lemma 1.1.16. *Let $A \subseteq \mathbb{C}[M]$ be a subspace stable under the action of T_N . Then*

$$A = \bigoplus_{\chi^m \in A} \mathbb{C} \cdot \chi^m.$$

Proof. Let $A' = \bigoplus_{\chi^m \in A} \mathbb{C} \cdot \chi^m$ and note that $A' \subseteq A$. For the opposite inclusion, pick $f \neq 0$ in A . Since $A \subseteq \mathbb{C}[M]$, we can write

$$f = \sum_{m \in \mathcal{B}} c_m \chi^m,$$

where $\mathcal{B} \subseteq M$ is finite and $c_m \neq 0$ for all $m \in \mathcal{B}$. Then $f \in B \cap A$, where

$$B = \text{Span}(\chi^m \mid m \in \mathcal{B}) \subseteq \mathbb{C}[M].$$

An easy computation shows that $t \cdot \chi^m = \chi^{m(t^{-1})} \chi^m$. It follows that B and hence $B \cap A$ are stable under the action of T_N . Since $B \cap A$ is finite-dimensional, Proposition 1.1.2 implies that $B \cap A$ is spanned by simultaneous eigenvectors of T_N . This is taking place in $\mathbb{C}[M]$, where simultaneous eigenvectors are characters. It follows that $B \cap A$ is spanned by characters. Then the above expression for $f \in B \cap A$ implies that $\chi^m \in A$ for $m \in \mathcal{B}$. Hence $f \in A'$, as desired. \square

We can now state the main result of this section, which asserts that our various approaches to affine toric varieties all give the same class of objects.

Theorem 1.1.17. *Let V be an affine variety. The following are equivalent:*

- (a) V is an affine toric variety according to Definition 1.1.3.
- (b) $V = Y_{\mathcal{A}}$ for a finite set \mathcal{A} in a lattice.

(c) V is an affine variety defined by a toric ideal.

(d) $V = \text{Spec}(\mathbb{C}[S])$ for an affine semigroup S .

Proof. The implications (b) \Leftrightarrow (c) \Leftrightarrow (d) \Rightarrow (a) follow from Propositions 1.1.8, 1.1.9 and 1.1.14. For (a) \Rightarrow (d), let V be an affine toric variety containing the torus T_N with character lattice M . Since the coordinate ring of T_N is the semigroup algebra $\mathbb{C}[M]$, the inclusion $T_N \subseteq V$ induces a map of coordinate rings

$$\mathbb{C}[V] \longrightarrow \mathbb{C}[M].$$

This map is injective since T_N is Zariski dense in V , so that we can regard $\mathbb{C}[V]$ as a subalgebra of $\mathbb{C}[M]$.

Since the action of T_N on V is given by a morphism $T_N \times V \rightarrow V$, we see that if $t \in T_N$ and $f \in \mathbb{C}[V]$, then $p \mapsto f(t^{-1} \cdot p)$ is a morphism on V . It follows that $\mathbb{C}[V] \subseteq \mathbb{C}[M]$ is stable under the action of T_N . By Lemma 1.1.16, we obtain

$$\mathbb{C}[V] = \bigoplus_{\chi^m \in \mathbb{C}[V]} \mathbb{C} \cdot \chi^m.$$

Hence $\mathbb{C}[V] \subseteq \mathbb{C}[S]$ for the semigroup $S = \{m \in M \mid \chi^m \in \mathbb{C}[V]\}$.

Finally, since $\mathbb{C}[V]$ is finitely generated, we can find $f_1, \dots, f_s \in \mathbb{C}[V]$ with $\mathbb{C}[V] = \mathbb{C}[f_1, \dots, f_s]$. Expressing each f_i in terms of characters as above gives a finite generating set of S . It follows that S is an affine semigroup. \square

Here is one way to think about the above proof. When an irreducible affine variety V contains a torus T_N as a Zariski open subset, we have the inclusion

$$\mathbb{C}[V] \subseteq \mathbb{C}[M].$$

Thus $\mathbb{C}[V]$ consists of those functions on the torus T_N that extend to polynomial functions on V . Then the key insight is that V is a toric variety *precisely when the functions that extend are determined by the characters that extend*.

Example 1.1.18. We have seen that $V = \mathbf{V}(xy - zw) \subseteq \mathbb{C}^4$ is a toric variety with toric ideal $\langle xy - zw \rangle \subseteq \mathbb{C}[x, y, z, w]$. Also, the torus is $(\mathbb{C}^*)^3$ via the map $(t_1, t_2, t_3) \mapsto (t_1, t_2, t_3, t_1 t_2 t_3^{-1})$. The lattice points used in this map can be represented as the columns of the matrix

$$(1.1.6) \quad \begin{pmatrix} 1 & 0 & 0 & 1 \\ 0 & 1 & 0 & 1 \\ 0 & 0 & 1 & -1 \end{pmatrix}.$$

The corresponding semigroup $S \subseteq \mathbb{Z}^3$ consists of the \mathbb{N} -linear combinations of the column vectors. Hence the elements of S are lattice points lying in the polyhedral region in \mathbb{R}^3 pictured in Figure 1 on the next page. In this figure, the four vectors generating S are shown in bold, and the boundary of the polyhedral region is partially shaded. In the terminology of §1.2, this polyhedral region is a *rational*

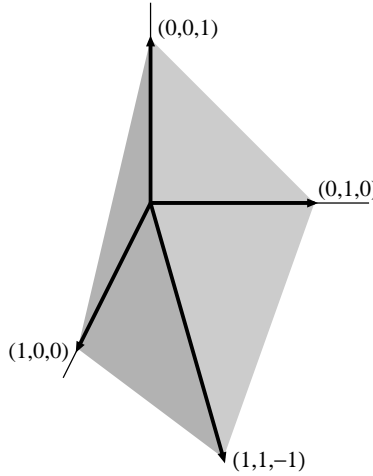

Figure 1. Cone containing the lattice points corresponding to $V = \mathbf{V}(xy - zw)$

polyhedral cone. In Exercise 1.1.5 you will show that S consists of *all* lattice points lying in the cone in Figure 1. We will use this in §1.3 to prove that V is normal. \diamond

Exercises for §1.1.

1.1.1. As in Example 1.1.6, let

$$I = \langle x_i x_{j+1} - x_{i+1} x_j \mid 0 \leq i < j \leq d-1 \rangle \subseteq \mathbb{C}[x_0, \dots, x_d]$$

and let \widehat{C}_d be the surface parametrized by

$$\Phi(s, t) = (s^d, s^{d-1}t, \dots, st^{d-1}, t^d) \in \mathbb{C}^{d+1}.$$

- Prove that $\mathbf{V}(I) = \Phi(\mathbb{C}^2) \subseteq \mathbb{C}^{d+1}$. Thus $\widehat{C}_d = \mathbf{V}(I)$.
- Prove that $\mathbf{I}(\widehat{C}_d)$ is homogeneous.
- Consider lex monomial order with $x_0 > x_1 > \dots > x_d$. Let $f \in \mathbf{I}(\widehat{C}_d)$ be homogeneous of degree ℓ and let r be the remainder of f on division by the generators of I . Prove that r can be written

$$r = h_0(x_0, x_1) + h_1(x_1, x_2) + \dots + h_{d-1}(x_{d-1}, x_d)$$

where h_i is homogeneous of degree ℓ . Also explain why we may assume that the coefficient of x_i^ℓ in h_i is zero for $1 \leq i \leq d-1$.

- Use part (c) and $r(s^d, s^{d-1}t, \dots, st^{d-1}, t^d) = 0$ to show that $r = 0$.
- Use parts (b), (c) and (d) to prove that $I = \mathbf{I}(\widehat{C}_d)$. Also explain why the generators of I are a Gröbner basis for the above lex order.

1.1.2. Let $L \subseteq \mathbb{Z}^s$ be a sublattice. Prove that

$$\langle x^{\ell_+} - x^{\ell_-} \mid \ell \in L \rangle = \langle x^\alpha - x^\beta \mid \alpha, \beta \in \mathbb{N}^s, \alpha - \beta \in L \rangle.$$

Note that when $\ell \in L$, the vectors $\ell_+, \ell_- \in \mathbb{N}^s$ have disjoint support (i.e., no coordinate is positive in both), while this may fail for arbitrary $\alpha, \beta \in \mathbb{N}^s$ with $\alpha - \beta \in L$.

1.1.3. Let I_L be a toric ideal and let ℓ^1, \dots, ℓ^r be a basis of the sublattice $L \subseteq \mathbb{Z}^s$. Define

$$I_{\mathbf{L}} = \langle x^{\ell^i_+} - x^{\ell^i_-} \mid i = 1, \dots, r \rangle.$$

Prove that $I_L = I_{\mathbf{L}} : \langle x_1 \cdots x_s \rangle^\infty$. Hint: Given $\alpha, \beta \in \mathbb{N}^s$ with $\alpha - \beta \in L$, write $\alpha - \beta = \sum_{i=1}^r a_i \ell^i$, $a_i \in \mathbb{Z}$. This implies

$$x^{\alpha - \beta} - 1 = \prod_{a_i > 0} \left(\frac{x^{\ell^i_+}}{x^{\ell^i_-}} \right)^{a_i} \prod_{a_i < 0} \left(\frac{x^{\ell^i_-}}{x^{\ell^i_+}} \right)^{-a_i} - 1.$$

Show that multiplying this by $(x_1 \cdots x_s)^k$ gives an element of $I_{\mathbf{L}}$ for $k \gg 0$. (By being more careful, one can show that this result holds for lattice ideals. See [123, Lem. 7.6].)

1.1.4. Fix an affine variety V . Then $f_1, \dots, f_s \in \mathbb{C}[V]$ give a polynomial map $\Phi : V \rightarrow \mathbb{C}^s$, which on coordinate rings is given by

$$\Phi^* : \mathbb{C}[x_1, \dots, x_s] \longrightarrow \mathbb{C}[V], \quad x_i \longmapsto f_i.$$

Let $Y \subseteq \mathbb{C}^s$ be the Zariski closure of the image of Φ .

- (a) Prove that $\mathbf{I}(Y) = \text{Ker}(\Phi^*)$.
- (b) Explain how this applies to the proof of Proposition 1.1.14.

1.1.5. Let $m_1 = (1, 0, 0), m_2 = (0, 1, 0), m_3 = (0, 0, 1), m_4 = (1, 1, -1)$ be the columns of the matrix in Example 1.1.18 and let

$$C = \left\{ \sum_{i=1}^4 \lambda_i m_i \mid \lambda_i \in \mathbb{R}_{\geq 0} \right\} \subseteq \mathbb{R}^3$$

be the cone in Figure 1. Prove that $C \cap \mathbb{Z}^3$ is a semigroup generated by m_1, m_2, m_3, m_4 .

1.1.6. An interesting observation is that different sets of lattice points can parametrize the same affine toric variety, even though these parametrizations behave slightly differently. In this exercise you will consider the parametrizations

$$\Phi_1(s, t) = (s^2, st, st^3) \quad \text{and} \quad \Phi_2(s, t) = (s^3, st, t^3).$$

- (a) Prove that Φ_1 and Φ_2 both give the affine toric variety $Y = \mathbf{V}(xz - y^3) \subseteq \mathbb{C}^3$.
- (b) We can regard Φ_1 and Φ_2 as maps

$$\Phi_1 : \mathbb{C}^2 \longrightarrow Y \quad \text{and} \quad \Phi_2 : \mathbb{C}^2 \longrightarrow Y.$$

Prove that Φ_2 is surjective and that Φ_1 is not.

In general, a finite subset $\mathcal{A} \subseteq \mathbb{Z}^n$ gives a rational map $\Phi_{\mathcal{A}} : \mathbb{C}^n \dashrightarrow Y_{\mathcal{A}}$. The image of $\Phi_{\mathcal{A}}$ in \mathbb{C}^s is called a *toric set* in the literature. Thus $\Phi_1(\mathbb{C}^2)$ and $\Phi_2(\mathbb{C}^2)$ are toric sets. The papers [101] and [147] study when a toric set equals the corresponding affine toric variety.

1.1.7. In Example 1.1.6 and Exercise 1.1.1 we constructed the rational normal cone \widehat{C}_d using all monomials of degree d in s, t . If we drop some of the monomials, things become more complicated. For example, consider the surface parametrized by

$$\Phi(s, t) = (s^4, s^3t, st^3, t^4) \in \mathbb{C}^4.$$

This gives a toric variety $Y \subseteq \mathbb{C}^4$. Show that the toric ideal of Y is given by

$$\mathbf{I}(Y) = \langle xw - yz, yw^2 - z^3, xz^2 - y^2w, x^2z - y^3 \rangle \subseteq \mathbb{C}[x, y, z, w].$$

The toric ideal for \widehat{C}_4 has quadratic generators; by removing the monomial s^2t^2 , we now get cubic generators. In Chapter 2 we will use this example to construct a projective curve that is normal but not projectively normal.

1.1.8. Instead of working over \mathbb{C} , we will work over an algebraically closed field k of characteristic 2. Consider the affine toric variety $V \subseteq k^5$ parametrized by

$$\Phi(s, t, u) = (s^4, t^4, u^4, s^8u, t^{12}u^3) \in k^5.$$

- Find generators for the toric ideal $I = \mathbf{I}(V) \subseteq k[x_1, x_2, x_3, x_4, x_5]$.
- Show that $\dim V = 3$. You may assume that Proposition 1.1.8 holds over k .
- Show that $I = \sqrt{\langle x_4^4 + x_1^8x_3, x_5^4 + x_2^{12}x_3^3 \rangle}$.

It follows that $V \subseteq k^5$ has codimension two and can be defined by two equations, i.e., V is a *set-theoretic complete intersection*. The paper [4] shows that if we replace k with an algebraically closed field of characteristic $p > 2$, then the above parametrization is *never* a set-theoretic complete intersection.

1.1.9. Prove that a lattice ideal I_L for $L \subseteq \mathbb{Z}^s$ is a toric ideal if and only if \mathbb{Z}^s/L is torsion-free. Hint: When \mathbb{Z}^s/L is torsion-free, it can be regarded as the character lattice of a torus. The other direction of the proof is more challenging. If you get stuck, see [123, Thm. 7.4].

1.1.10. Prove that $I = \langle x^2 - 1, xy - 1, yz - 1 \rangle$ is the lattice ideal for the lattice

$$L = \{(a, b, c) \in \mathbb{Z}^3 \mid a + b + c \equiv 0 \pmod{2}\} \subseteq \mathbb{Z}^3.$$

Also compute primary decomposition of I to show that I is not prime.

1.1.11. Let T_N be a torus with character lattice M . Then every point $t \in T_N$ gives an evaluation map $\phi_t : M \rightarrow \mathbb{C}^*$ defined by $\phi_t(m) = \chi^m(t)$. Prove that ϕ_t is a group homomorphism and that the map $t \mapsto \phi_t$ induces a group isomorphism

$$T_N \simeq \text{Hom}_{\mathbb{Z}}(M, \mathbb{C}^*).$$

1.1.12. Consider tori T_1 and T_2 with character lattices M_1 and M_2 . By Example 1.1.13, the coordinate rings of T_1 and T_2 are $\mathbb{C}[M_1]$ and $\mathbb{C}[M_2]$. Let $\Phi : T_1 \rightarrow T_2$ be a morphism that is a group homomorphism. Then Φ induces maps

$$\widehat{\Phi} : M_2 \longrightarrow M_1 \quad \text{and} \quad \Phi^* : \mathbb{C}[M_2] \longrightarrow \mathbb{C}[M_1]$$

by composition. Prove that Φ^* is the map of semigroup algebras induced by the map $\widehat{\Phi}$ of affine semigroups.

1.1.13. A commutative semigroup S is *cancellative* if $u + v = u + w$ implies $v = w$ for all $u, v, w \in S$ and *torsion-free* if $nu = 0$ implies $u = 0$ for all $n \in \mathbb{N} \setminus \{0\}$ and $u \in S$. Prove that S is affine if and only if it is finitely generated, cancellative, and torsion-free.

1.1.14. The requirement that an affine semigroup be finitely generated is important since lattices contain semigroups that are not finitely generated. For example, let $\tau > 0$ be irrational and consider the semigroup

$$S = \{(a, b) \in \mathbb{N}^2 \mid b \geq \tau a\} \subseteq \mathbb{Z}^2.$$

Prove that S is not finitely generated. (When τ satisfies a quadratic equation with integer coefficients, the generators of S are related to continued fractions. For example, when $\tau = (1 + \sqrt{5})/2$ is the golden ratio, the minimal generators of S are $(1, 0)$ and (F_{2n-1}, F_{2n}) for $n = 1, 2, \dots$, where F_n is the n th Fibonacci number. See [162] for further details.)

1.1.15. Suppose that $\phi : M \rightarrow M$ is a group isomorphism. Fix a finite set $\mathcal{A} \subseteq M$ and let $\mathcal{B} = \phi(\mathcal{A})$. Prove that the toric varieties $Y_{\mathcal{A}}$ and $Y_{\mathcal{B}}$ are equivariantly isomorphic (meaning that the isomorphism respects the torus action).

§1.2. Cones and Affine Toric Varieties

We begin with a brief discussion of rational polyhedral cones and then explain how they relate to affine toric varieties.

Convex Polyhedral Cones. Fix a pair of dual vector spaces $M_{\mathbb{R}}$ and $N_{\mathbb{R}}$. Our discussion of cones will omit most proofs—we refer the reader to [58] for more details and [134, App. A.1] for careful statements. See also [24, 74, 149].

Definition 1.2.1. A *convex polyhedral cone* in $N_{\mathbb{R}}$ is a set of the form

$$\sigma = \text{Cone}(S) = \left\{ \sum_{u \in S} \lambda_u u \mid \lambda_u \geq 0 \right\} \subseteq N_{\mathbb{R}},$$

where $S \subseteq N_{\mathbb{R}}$ is finite. We say that σ is *generated* by S . Also set $\text{Cone}(\emptyset) = \{0\}$.

A convex polyhedral cone σ is in fact *convex*, meaning that $x, y \in \sigma$ implies $\lambda x + (1 - \lambda)y \in \sigma$ for all $0 \leq \lambda \leq 1$, and is a *cone*, meaning that $x \in \sigma$ implies $\lambda x \in \sigma$ for all $\lambda \geq 0$. Since we will only consider convex cones, the cones satisfying Definition 1.2.1 will be called simply “polyhedral cones.”

Examples of polyhedral cones include the first quadrant in \mathbb{R}^2 or first octant in \mathbb{R}^3 . For another example, the cone $\text{Cone}(e_1, e_2, e_1 + e_3, e_2 + e_3) \subseteq \mathbb{R}^3$ is pictured in Figure 2. It is also possible to have cones that contain entire lines. For example,

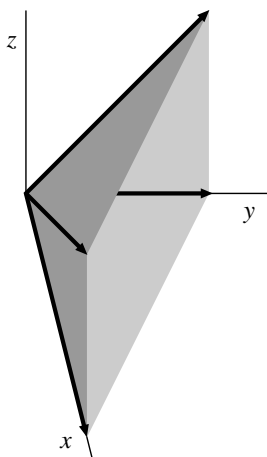

Figure 2. Cone in \mathbb{R}^3 generated by $e_1, e_2, e_1 + e_3, e_2 + e_3$

$\text{Cone}(e_1, -e_1) \subseteq \mathbb{R}^2$ is the x -axis, while $\text{Cone}(e_1, -e_1, e_2)$ is the closed upper half-plane $\{(x, y) \in \mathbb{R}^2 \mid y \geq 0\}$. As we will see below, these last two examples are not *strongly convex*.

We can also create cones using *polytopes*, which are defined as follows.

Definition 1.2.2. A *polytope* in $N_{\mathbb{R}}$ is a set of the form

$$P = \text{Conv}(S) = \left\{ \sum_{u \in S} \lambda_u u \mid \lambda_u \geq 0, \sum_{u \in S} \lambda_u = 1 \right\} \subseteq N_{\mathbb{R}},$$

where $S \subseteq N_{\mathbb{R}}$ is finite. We say that P is the *convex hull* of S .

Polytopes include all polygons in \mathbb{R}^2 and bounded polyhedra in \mathbb{R}^3 . As we will see in later chapters, polytopes play a prominent role in the theory of toric varieties. Here, however, we simply observe that a polytope $P \subseteq N_{\mathbb{R}}$ gives a polyhedral cone in $N_{\mathbb{R}} \times \mathbb{R}$ by taking the cone

$$\sigma = \{\lambda \cdot (u, 1) \in N_{\mathbb{R}} \times \mathbb{R} \mid u \in P, \lambda \geq 0\}.$$

If $P = \text{Conv}(S)$, then we can also describe this as $\sigma = \text{Cone}(S \times \{1\})$. Figure 3 shows what this looks when P is a pentagon in the plane.

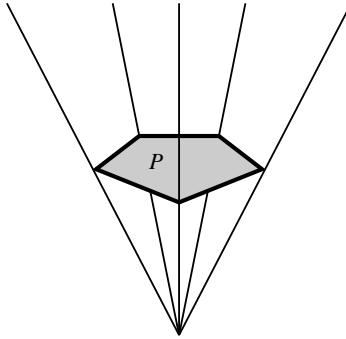

Figure 3. Cone over a pentagon $P \subseteq \mathbb{R}^2$

The *dimension* $\dim \sigma$ of a polyhedral cone σ is the dimension of the smallest subspace $W = \text{Span}(\sigma)$ of $N_{\mathbb{R}}$ containing σ . We call $\text{Span}(\sigma)$ the *span* of σ .

Dual Cones and Faces. As usual, the pairing between $M_{\mathbb{R}}$ and $N_{\mathbb{R}}$ is denoted $\langle \cdot, \cdot \rangle$.

Definition 1.2.3. Given a polyhedral cone $\sigma \subseteq N_{\mathbb{R}}$, its *dual cone* is defined by

$$\sigma^{\vee} = \{m \in M_{\mathbb{R}} \mid \langle m, u \rangle \geq 0 \text{ for all } u \in \sigma\}.$$

Duality has the following important properties.

Proposition 1.2.4. Let $\sigma \subseteq N_{\mathbb{R}}$ be a polyhedral cone. Then σ^{\vee} is a polyhedral cone in $M_{\mathbb{R}}$ and $(\sigma^{\vee})^{\vee} = \sigma$. \square

Given $m \neq 0$ in $N_{\mathbb{R}}$, we get the hyperplane

$$H_m = \{u \in N_{\mathbb{R}} \mid \langle m, u \rangle = 0\} \subseteq N_{\mathbb{R}}$$

and the closed half-space

$$H_m^+ = \{u \in N_{\mathbb{R}} \mid \langle m, u \rangle \geq 0\} \subseteq N_{\mathbb{R}}.$$

Then H_m is a *supporting hyperplane* of a polyhedral cone $\sigma \subseteq N_{\mathbb{R}}$ if $\sigma \subseteq H_m^+$, and H_m^+ is a *supporting half-space*. Note that H_m is a supporting hyperplane of σ if and only if $m \in \sigma^\vee \setminus \{0\}$. Furthermore, if m_1, \dots, m_s generate σ^\vee , then it is straightforward to check that

$$(1.2.1) \quad \sigma = H_{m_1}^+ \cap \cdots \cap H_{m_s}^+.$$

Thus every polyhedral cone is an intersection of finitely many closed half-spaces.

We can use supporting hyperplanes and half-spaces to define *faces* of a cone.

Definition 1.2.5. A *face of a cone* of the polyhedral cone σ is $\tau = H_m \cap \sigma$ for some $m \in \sigma^\vee$, written $\tau \preceq \sigma$. Using $m = 0$ shows that σ is a face of itself, i.e., $\sigma \preceq \sigma$. Faces $\tau \neq \sigma$ are called *proper faces*, written $\tau \prec \sigma$.

The faces of a polyhedral cone have the following obvious properties.

Lemma 1.2.6. Let $\sigma = \text{Cone}(S)$ be a polyhedral cone. Then:

- (a) Every face of σ is a polyhedral cone.
- (b) An intersection of two faces of σ is again a face of σ .
- (c) A face of a face of σ is again a face of σ . □

You will prove the following useful property of faces in Exercise 1.2.1.

Lemma 1.2.7. Let τ be a face of a polyhedral cone σ . If $v, w \in \sigma$ and $v + w \in \tau$, then $v, w \in \tau$. □

A *facet* of σ is a face τ of codimension 1, i.e., $\dim \tau = \dim \sigma - 1$. An *edge* of σ is a face of dimension 1. In Figure 4 on the next page we illustrate a 3-dimensional cone with shaded facets and a supporting hyperplane (a plane in this case) that cuts out the vertical edge of the cone.

Here are some properties of facets.

Proposition 1.2.8. Let $\sigma \subseteq N_{\mathbb{R}} \simeq \mathbb{R}^n$ be a polyhedral cone. Then:

- (a) If $\sigma = H_{m_1}^+ \cap \cdots \cap H_{m_s}^+$ for $m_i \in \sigma^\vee$, $1 \leq i \leq s$, then $\sigma^\vee = \text{Cone}(m_1, \dots, m_s)$.
- (b) If $\dim \sigma = n$, then in (a) we can assume that the facets of σ are $\tau_i = H_{m_i} \cap \sigma$.
- (c) Every proper face $\tau \prec \sigma$ is the intersection of the facets of σ containing τ . □

Note how part (b) of the proposition refines (1.2.1) when $\dim \sigma = \dim N_{\mathbb{R}}$.

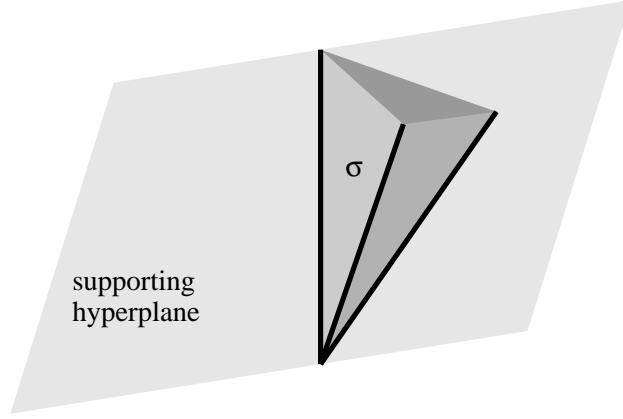

Figure 4. A cone $\sigma \subseteq \mathbb{R}^3$ with shaded facets and a hyperplane supporting an edge

When working in \mathbb{R}^n , dot product allows us to identify the dual with \mathbb{R}^n . From this point of view, the vectors m_1, \dots, m_s in part (a) of the proposition are *facet normals*, i.e., perpendicular to the facets. This makes it easy to compute examples.

Example 1.2.9. It easy to see that the facet normals to the cone $\sigma \subseteq \mathbb{R}^3$ in Figure 2 are $m_1 = e_1, m_2 = e_2, m_3 = e_3, m_4 = e_1 + e_2 - e_3$. Hence

$$\sigma^\vee = \text{Cone}(e_1, e_2, e_3, e_1 + e_2 - e_3) \subseteq \mathbb{R}^3.$$

This is the cone of Figure 1 at the end of §1.1 whose lattice points describe the semigroup of the affine toric variety $\mathbf{V}(xy - zw)$ (see Example 1.1.18). As we will see, this is part of how cones describe normal affine toric varieties.

Now consider σ^\vee , which is the cone in Figure 1. The reader can check that the facet normals of this cone are $e_1, e_2, e_1 + e_3, e_2 + e_3$. Using duality and part (b) of Proposition 1.2.8, we obtain

$$\sigma = (\sigma^\vee)^\vee = \text{Cone}(e_1, e_2, e_1 + e_3, e_2 + e_3).$$

Hence we recover our original description of σ . ◇

In this example, facets of the cone correspond to edges of its dual. More generally, given a face $\tau \preceq \sigma \subseteq N_{\mathbb{R}}$, we define

$$\begin{aligned} \tau^\perp &= \{m \in M_{\mathbb{R}} \mid \langle m, u \rangle = 0 \text{ for all } u \in \tau\} \\ \tau^* &= \{m \in \sigma^\vee \mid \langle m, u \rangle = 0 \text{ for all } u \in \tau\} \\ &= \sigma^\vee \cap \tau^\perp. \end{aligned}$$

We call τ^* the *dual face* of τ because of the following proposition.

Proposition 1.2.10. *If τ is a face of a polyhedral cone σ and $\tau^* = \sigma^\vee \cap \tau^\perp$, then:*

(a) τ^* is a face of σ^\vee .

- (b) The map $\tau \mapsto \tau^*$ is a bijective inclusion-reversing correspondence between the faces of σ and the faces of σ^\vee .
- (c) $\dim \tau + \dim \tau^* = n$. □

Here is an example of Proposition 1.2.10 when $\dim \sigma < \dim N_{\mathbb{R}}$.

Example 1.2.11. Let $\sigma = \text{Cone}(e_1, e_2) \subseteq \mathbb{R}^3$. Figure 5 shows σ and σ^\vee . You

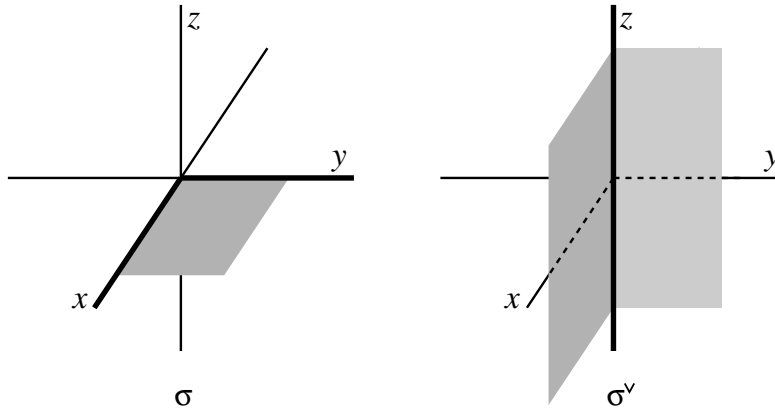

Figure 5. A 2-dimensional cone $\sigma \subseteq \mathbb{R}^3$ and its dual $\sigma^\vee \subseteq \mathbb{R}^3$

should check that the maximal face of σ , namely σ itself, gives the minimal face σ^* of σ^\vee , namely the z -axis. Note also that

$$\dim \sigma + \dim \sigma^* = 3$$

even though σ has dimension 2. ◇

Relative Interiors. As already noted, the *span* of a cone $\sigma \subseteq N_{\mathbb{R}}$ is the smallest subspace of $N_{\mathbb{R}}$ containing σ . Then the *relative interior* of σ , denoted $\text{Relint}(\sigma)$, is the interior of σ in its span. Exercise 1.2.2 will characterize $\text{Relint}(\sigma)$ as follows:

$$u \in \text{Relint}(\sigma) \iff \langle m, u \rangle > 0 \text{ for all } m \in \sigma^\vee \setminus \sigma^\perp.$$

When the span equals $N_{\mathbb{R}}$, the relative interior is just the interior, denoted $\text{Int}(\sigma)$.

For an example of how relative interiors arise naturally, suppose that $\tau \preceq \sigma$. This gives the dual face $\tau^* = \sigma^\vee \cap \tau^\perp$ of σ^\vee . Furthermore, if $m \in \sigma^\vee$, then one easily sees that

$$m \in \tau^* \iff \tau \subseteq H_m \cap \sigma.$$

In Exercise 1.2.2, you will show that if $m \in \sigma^\vee$, then

$$m \in \text{Relint}(\tau^*) \iff \tau = H_m \cap \sigma.$$

Thus the relative interior $\text{Relint}(\tau^*)$ tells us exactly which supporting hyperplanes of σ cut out the face τ .

Strong Convexity. Of the cones shown in Figures 1–5, all but σ^\vee in Figure 5 have the nice property that the origin is a face. Such cones are called *strongly convex*. This condition can be stated several ways.

Proposition 1.2.12. *Let $\sigma \subseteq N_{\mathbb{R}} \simeq \mathbb{R}^n$ be a polyhedral cone. Then:*

$$\begin{aligned} \sigma \text{ is strongly convex} &\iff \{0\} \text{ is a face of } \sigma \\ &\iff \sigma \text{ contains no positive-dimensional subspace of } N_{\mathbb{R}} \\ &\iff \sigma \cap (-\sigma) = \{0\} \\ &\iff \dim \sigma^\vee = n. \end{aligned} \quad \square$$

You will prove Proposition 1.2.12 in Exercise 1.2.3. One corollary is that if a polyhedral cone σ is strongly convex of maximal dimension, then so is σ^\vee . The cones pictured in Figures 1–4 satisfy this condition.

In general, a polyhedral cone σ always has a minimal face that is the largest subspace W contained in σ . Furthermore:

- $W = \sigma \cap (-\sigma)$.
- $W = H_m \cap \sigma$ whenever $m \in \text{Relint}(\sigma^\vee)$.
- $\bar{\sigma} = \sigma/W \subseteq N_{\mathbb{R}}/W$ is a strongly convex polyhedral cone.

See Exercise 1.2.4.

Separation. When two cones intersect in a face of each, we can separate the cones with the following result, often called the *Separation Lemma*.

Lemma 1.2.13 (Separation Lemma). *Let σ_1, σ_2 be polyhedral cones in $N_{\mathbb{R}}$ that meet along a common face $\tau = \sigma_1 \cap \sigma_2$. Then*

$$\tau = H_m \cap \sigma_1 = H_m \cap \sigma_2$$

for any $m \in \text{Relint}(\sigma_1^\vee \cap (-\sigma_2)^\vee)$.

Proof. Given $A, B \subseteq N_{\mathbb{R}}$, we set $A - B = \{a - b \mid a \in A, b \in B\}$. A standard result from cone theory tells us that

$$\sigma_1^\vee \cap (-\sigma_2)^\vee = (\sigma_1 - \sigma_2)^\vee.$$

Now fix $m \in \text{Relint}(\sigma_1^\vee \cap (-\sigma_2)^\vee)$. The above equation and Exercise 1.2.4 imply that H_m cuts out the minimal face of $\sigma_1 - \sigma_2$, i.e.,

$$H_m \cap (\sigma_1 - \sigma_2) = (\sigma_1 - \sigma_2) \cap (\sigma_2 - \sigma_1).$$

However, we also have

$$(\sigma_1 - \sigma_2) \cap (\sigma_2 - \sigma_1) = \tau - \tau.$$

One inclusion is obvious since $\tau = \sigma_1 \cap \sigma_2$. For the other inclusion, write $u \in (\sigma_1 - \sigma_2) \cap (\sigma_2 - \sigma_1)$ as

$$u = a_1 - a_2 = b_2 - b_1, \quad a_1, b_1 \in \sigma_1, \quad a_2, b_2 \in \sigma_2.$$

Then $a_1 + b_1 = a_2 + b_2$ implies that this element lies in $\tau = \sigma_1 \cap \sigma_2$. Since $a_1, b_1 \in \sigma_1$, we have $a_1, b_1 \in \tau$ by Lemma 1.2.7, and $a_2, b_2 \in \tau$ follows similarly. Hence $u = a_1 - a_2 \in \tau - \tau$, as desired.

We conclude that $H_m \cap (\sigma_1 - \sigma_2) = \tau - \tau$. Intersecting with σ_1 , we obtain

$$H_m \cap \sigma_1 = (\tau - \tau) \cap \sigma_1 = \tau,$$

where the last equality again uses Lemma 1.2.7 (Exercise 1.2.5). If instead we intersect with $-\sigma_2$, we obtain

$$H_m \cap (-\sigma_2) = (\tau - \tau) \cap (-\sigma_2) = -\tau,$$

and $H_m \cap \sigma_2 = \tau$ follows. □

In the situation of Lemma 1.2.13 we call H_m a *separating hyperplane*.

Rational Polyhedral Cones. Let N and M be dual lattices with associated vector spaces $N_{\mathbb{R}} = N \otimes_{\mathbb{Z}} \mathbb{R}$ and $M_{\mathbb{R}} = M \otimes_{\mathbb{Z}} \mathbb{R}$. For \mathbb{R}^n we usually use the lattice \mathbb{Z}^n .

Definition 1.2.14. A polyhedral cone $\sigma \subseteq N_{\mathbb{R}}$ is *rational* if $\sigma = \text{Cone}(S)$ for some finite set $S \subseteq N$.

The cones appearing in Figures 1, 2 and 5 are rational. We note without proof that faces and duals of rational polyhedral cones are rational. Furthermore, if $\sigma = \text{Cone}(S)$ for $S \subseteq N$ finite and $N_{\mathbb{Q}} = N \otimes_{\mathbb{Z}} \mathbb{Q}$, then

$$(1.2.2) \quad \sigma \cap N_{\mathbb{Q}} = \left\{ \sum_{u \in S} \lambda_u u \mid \lambda_u \geq 0 \text{ in } \mathbb{Q} \right\}.$$

One new feature is that a strongly convex rational polyhedral cone σ has a canonical generating set, constructed as follows. Let ρ be an edge of σ . Since σ is strongly convex, ρ is a *ray*, i.e., a half-line, and since ρ is rational, the semigroup $\rho \cap N$ is generated by a unique element $u_{\rho} \in \rho \cap N$. We call u_{ρ} the *ray generator* of ρ . Figure 6 shows the ray generator of a rational ray ρ in the plane. The dots are the lattice $N = \mathbb{Z}^2$ and the white ones are $\rho \cap N$.

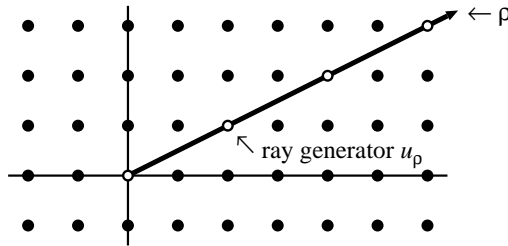

Figure 6. A rational ray $\rho \subseteq \mathbb{R}^2$ and its unique ray generator u_{ρ}

Lemma 1.2.15. A strongly convex rational polyhedral cone is generated by the ray generators of its edges. □

It is customary to call the ray generators of the edges the *minimal generators* of a strongly convex rational polyhedral cone. Figures 1 and 2 show 3-dimensional strongly convex rational polyhedral cones and their ray generators.

In a similar way, a rational polyhedral cone σ of maximal dimension has unique *facet normals*, which are the ray generators of the dual σ^\vee , which is strongly convex by Proposition 1.2.12.

Here are some especially important strongly convex cones.

Definition 1.2.16. Let $\sigma \subseteq N_{\mathbb{R}}$ be a strongly convex rational polyhedral cone.

- (a) σ is *smooth* or *regular* if its minimal generators form part of a \mathbb{Z} -basis of N ,
- (b) σ is *simplicial* if its minimal generators are linearly independent over \mathbb{R} .

The cone σ pictured in Figure 5 is smooth, while those in Figures 1 and 2 are not even simplicial. Note also that the dual of a smooth (resp. simplicial) cone is again smooth (resp. simplicial). Later in the section we will give examples of simplicial cones that are not smooth.

Semigroup Algebras and Affine Toric Varieties. Given a rational polyhedral cone $\sigma \subseteq N_{\mathbb{R}}$, the lattice points

$$S_\sigma = \sigma^\vee \cap M \subseteq M$$

form a semigroup. A key fact is that this semigroup is finitely generated.

Proposition 1.2.17 (Gordan's Lemma). $S_\sigma = \sigma^\vee \cap M$ is finitely generated and hence is an affine semigroup.

Proof. Since σ^\vee is rational polyhedral, $\sigma^\vee = \text{Cone}(T)$ for a finite set $T \subseteq M$. Then $K = \{\sum_{m \in T} \delta_m m \mid 0 \leq \delta_m < 1\}$ is a bounded region of $M_{\mathbb{R}} \simeq \mathbb{R}^n$, so that $K \cap M$ is finite since $M \simeq \mathbb{Z}^n$. Note that $T \cup (K \cap M) \subseteq S_\sigma$.

We claim $T \cup (K \cap M)$ generates S_σ as a semigroup. To prove this, take $w \in S_\sigma$ and write $w = \sum_{m \in T} \lambda_m m$ where $\lambda_m \geq 0$. Then $\lambda_m = \lfloor \lambda_m \rfloor + \delta_m$ with $\lfloor \lambda_m \rfloor \in \mathbb{N}$ and $0 \leq \delta_m < 1$, so that

$$w = \sum_{m \in T} \lfloor \lambda_m \rfloor m + \sum_{m \in T} \delta_m m.$$

The second sum is in $K \cap M$ (remember $w \in M$). It follows that w is a nonnegative integer combination of elements of $T \cup (K \cap M)$. \square

Since affine semigroups give affine toric varieties, we get the following.

Theorem 1.2.18. Let $\sigma \subseteq N_{\mathbb{R}} \simeq \mathbb{R}^n$ be a rational polyhedral cone with semigroup $S_\sigma = \sigma^\vee \cap M$. Then

$$U_\sigma = \text{Spec}(\mathbb{C}[S_\sigma]) = \text{Spec}(\mathbb{C}[\sigma^\vee \cap M])$$

is an affine toric variety. Furthermore,

$$\dim U_\sigma = n \iff \text{the torus of } U_\sigma \text{ is } T_N = N \otimes_{\mathbb{Z}} \mathbb{C}^* \iff \sigma \text{ is strongly convex.}$$

Proof. By Gordan's Lemma and Proposition 1.1.14, U_σ is an affine toric variety whose torus has character lattice $\mathbb{Z}S_\sigma \subseteq M$. To study $\mathbb{Z}S_\sigma$, note that

$$\mathbb{Z}S_\sigma = S_\sigma - S_\sigma = \{m_1 - m_2 \mid m_1, m_2 \in S_\sigma\}.$$

Now suppose that $km \in \mathbb{Z}S_\sigma$ for some $k > 1$ and $m \in M$. Then $km = m_1 - m_2$ for $m_1, m_2 \in S_\sigma = \sigma^\vee \cap M$. Since m_1 and m_2 lie in the convex set σ^\vee , we have

$$m + m_2 = \frac{1}{k}m_1 + \frac{k-1}{k}m_2 \in \sigma^\vee.$$

It follows that $m = (m + m_2) - m_2 \in \mathbb{Z}S_\sigma$, so that $M/\mathbb{Z}S_\sigma$ is torsion-free. Hence

$$(1.2.3) \quad \text{the torus of } U_\sigma \text{ is } T_N \iff \mathbb{Z}S_\sigma = M \iff \text{rank } \mathbb{Z}S_\sigma = n.$$

Since σ is strongly convex if and only if $\dim \sigma^\vee = n$ (Proposition 1.2.12), it remains to show that

$$\dim U_\sigma = n \iff \text{rank } \mathbb{Z}S_\sigma = n \iff \dim \sigma^\vee = n.$$

The first equivalence follows since the dimension of an affine toric variety is the dimension of its torus, which is the rank of its character lattice. We leave the proof of the second equivalence to the reader (Exercise 1.2.6). \square

Since we want our affine toric varieties to contain the torus T_N , we consider only those affine toric varieties U_σ for which $\sigma \subseteq N_\mathbb{R}$ is strongly convex.

Our first example of Theorem 1.2.18 is an affine toric variety we know well.

Example 1.2.19. Let $\sigma = \text{Cone}(e_1, e_2, e_1 + e_3, e_2 + e_3) \subseteq N_\mathbb{R} = \mathbb{R}^3$ with $N = \mathbb{Z}^3$. This is the cone pictured in Figure 2. By Example 1.2.9, σ^\vee is the cone pictured in Figure 1, and by Example 1.1.18, the lattice points in this cone are generated by columns of matrix (1.1.6). It follows from Example 1.1.18 that U_σ is the affine toric variety $\mathbf{V}(xy - zw)$. \diamond

Here are two further examples of Theorem 1.2.18.

Example 1.2.20. Fix $0 \leq r \leq n$ and set $\sigma = \text{Cone}(e_1, \dots, e_r) \subseteq \mathbb{R}^n$. Then

$$\sigma^\vee = \text{Cone}(e_1, \dots, e_r, \pm e_{r+1}, \dots, \pm e_n)$$

and the corresponding affine toric variety is

$$U_\sigma = \text{Spec}(\mathbb{C}[x_1, \dots, x_r, x_{r+1}^{\pm 1}, \dots, x_n^{\pm 1}]) = \mathbb{C}^r \times (\mathbb{C}^*)^{n-r}$$

(Exercise 1.2.7). This implies the general fact that if $\sigma \subseteq N_\mathbb{R} \simeq \mathbb{R}^n$ is a smooth cone of dimension r , then $U_\sigma \simeq \mathbb{C}^r \times (\mathbb{C}^*)^{n-r}$. \diamond

Figure 5 illustrates the cones in Example 1.2.20 when $r = 2$ and $n = 3$.

Example 1.2.21. Fix a positive integer d and let $\sigma = \text{Cone}(de_1 - e_2, e_2) \subseteq \mathbb{R}^2$. This has dual cone $\sigma^\vee = \text{Cone}(e_1, e_1 + de_2)$. Figure 7 on the next page shows σ^\vee when $d = 4$. The affine semigroup $S_\sigma = \sigma^\vee \cap \mathbb{Z}^2$ is generated by the lattice points

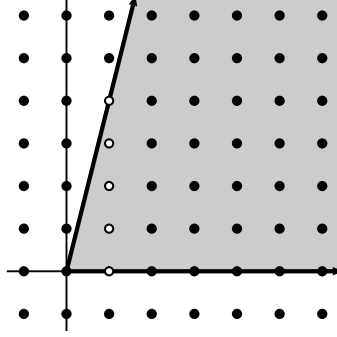

Figure 7. The cone σ^\vee when $d = 4$

$(1, i)$ for $0 \leq i \leq d$. When $d = 4$, these are the white dots in Figure 7. (You will prove these assertions in Exercise 1.2.8.)

By §1.1, the affine toric variety U_σ is the Zariski closure of the image of the map $\Phi : (\mathbb{C}^*)^2 \rightarrow \mathbb{C}^{d+1}$ defined by

$$\Phi(s, t) = (s, st, st^2, \dots, st^d).$$

This map has the same image as the map $(s, t) \mapsto (s^d, s^{d-1}t, \dots, st^{d-1}, t^d)$ used in Example 1.1.6. Thus U_σ is isomorphic to the rational normal cone $\widehat{C}_d \subseteq \mathbb{C}^{d+1}$ whose ideal is generated by the 2×2 minors of the matrix

$$\begin{pmatrix} x_0 & x_1 & \cdots & x_{d-2} & x_{d-1} \\ x_1 & x_2 & \cdots & x_{d-1} & x_d \end{pmatrix}.$$

Note that the cones σ and σ^\vee are simplicial but not smooth. \diamond

We will return to this example often. One thing evident in Example 1.1.6 is the difference between *cone generators* and *semigroup generators*: the cone σ^\vee has two generators but the semigroup $S_\sigma = \sigma^\vee \cap \mathbb{Z}^2$ has $d + 1$.

When $\sigma \subseteq N_{\mathbb{R}}$ has maximal dimension, the semigroup $S_\sigma = \sigma^\vee \cap M$ has a unique minimal generating set constructed as follows. Define an element $m \neq 0$ of S_σ to be *irreducible* if $m = m' + m''$ for $m', m'' \in S_\sigma$ implies $m' = 0$ or $m'' = 0$.

Proposition 1.2.22. *Let $\sigma \subseteq N_{\mathbb{R}}$ be strongly convex of maximal dimension and let $S_\sigma = \sigma^\vee \cap M$. Then*

$$\mathcal{H} = \{m \in S_\sigma \mid m \text{ is irreducible}\}$$

has the following properties:

- (a) \mathcal{H} is finite and generates S_σ .
- (b) \mathcal{H} contains the ray generators of the edges of σ^\vee .
- (c) \mathcal{H} is the minimal generating set of S_σ with respect to inclusion.

Proof. Proposition 1.2.12 implies that σ^\vee is strongly convex, so we can find an element $u \in \sigma \cap N \setminus \{0\}$ such that $\langle m, u \rangle \in \mathbb{N}$ for all $m \in S_\sigma$ and $\langle m, u \rangle = 0$ if and only if $m = 0$.

Now suppose that $m \in S_\sigma$ is not irreducible. Then $m = m' + m''$ where m' and m'' are nonzero elements of S_σ . It follows that

$$\langle m, u \rangle = \langle m', u \rangle + \langle m'', u \rangle$$

with $\langle m', u \rangle, \langle m'', u \rangle \in \mathbb{N} \setminus \{0\}$, so that

$$\langle m', u \rangle < \langle m, u \rangle \quad \text{and} \quad \langle m'', u \rangle < \langle m, u \rangle.$$

Using induction on $\langle m, u \rangle$, we conclude that every element of S_σ is a sum of irreducible elements, so that \mathcal{H} generates S_σ . Furthermore, using a finite generating set of S_σ , one easily sees that \mathcal{H} is finite. This proves part (a). The remaining parts of the proof are covered in Exercise 1.2.9. \square

The set $\mathcal{H} \subseteq S_\sigma$ is called the *Hilbert basis* of S_σ and its elements are the *minimal generators* of S_σ . More generally, Proposition 1.2.22 holds for any affine semigroup S satisfying $S \cap (-S) = \{0\}$. Algorithms for computing Hilbert bases are discussed in [123, 7.3] and [166, Ch. 13], and Hilbert bases can be computed using the computer program Normaliz [27].

Exercises for §1.2.

1.2.1. Prove Lemma 1.2.7. Hint: Write $\tau = H_m \cap \sigma$ for $m \in \sigma^\vee$.

1.2.2. Here are some properties of relative interiors. Let $\sigma \subseteq N_{\mathbb{R}}$ be a cone.

- (a) Show that if $u \in \sigma^\vee$, then $u \in \text{Relint}(\sigma)$ if and only if $\langle m, u \rangle > 0$ for all $m \in \sigma^\vee \setminus \sigma^\perp$.
 (b) Let $\tau \preceq \sigma$ and fix $m \in \sigma^\vee$. Prove that

$$\begin{aligned} m \in \tau^* &\iff \tau \subseteq H_m \cap \sigma \\ m \in \text{Relint}(\tau^*) &\iff \tau = H_m \cap \sigma. \end{aligned}$$

1.2.3. Prove Proposition 1.2.12.

1.2.4. Let $\sigma \subseteq N_{\mathbb{R}}$ be a polyhedral cone.

- (a) Use Proposition 1.2.10 to show that σ has a unique minimal face with respect to \preceq . Let W denote this minimal face.
 (b) Prove that $W = (\sigma^\vee)^\perp$.
 (c) Prove that W is the largest subspace contained in σ .
 (d) Prove that $W = \sigma \cap (-\sigma)$.
 (e) Fix $m \in \sigma^\vee$. Prove that $m \in \text{Relint}(\sigma^\vee)$ if and only if $W = H_m \cap \sigma$.
 (f) Prove that $\bar{\sigma} = \sigma/W \subseteq N_{\mathbb{R}}/W$ is a strongly convex polyhedral cone.

1.2.5. Let $\tau \preceq \sigma \subseteq N_{\mathbb{R}}$ and let $\tau - \tau$ be defined as in the proof of Lemma 1.2.13. Prove that $\tau = (\tau - \tau) \cap \tau$. Also show that $\tau - \tau = \text{Span}(\tau)$, i.e., $\tau - \tau$ is the smallest subspace of $N_{\mathbb{R}}$ containing τ .

1.2.6. Fix a lattice M and let $\text{Span}(S)$ denote the span over \mathbb{R} of a subset $S \subseteq M_{\mathbb{R}}$.

- Let $S \subseteq M$ be finite. Prove that $\text{rank } \mathbb{Z}S = \dim \text{Span}(S)$.
- Let $S \subseteq M_{\mathbb{R}}$ be finite. Prove that $\dim \text{Cone}(S) = \dim \text{Span}(S)$.
- Use parts (a) and (b) to complete the proof of Theorem 1.2.18.

1.2.7. Prove the assertions made in Example 1.2.20.

1.2.8. Prove the assertions made in Example 1.2.21. Hint: First show that when a cone is smooth, the ray generators of the cone also generate the corresponding semigroup. Then write the cone σ^{\vee} of Example 1.2.21 as a union of such cones.

1.2.9. Complete the proof of Proposition 1.2.22. Hint for part (b): Show that the ray generators of the edges of σ^{\vee} are irreducible in S_{σ} . Given an edge ρ of σ^{\vee} , it will help to pick $u \in \sigma \cap N \setminus \{0\}$ such that $\rho = H_u \cap \sigma^{\vee}$.

1.2.10. Let $\sigma \subseteq N_{\mathbb{R}}$ be a cone generated by a set of linearly independent vectors in $N_{\mathbb{R}}$. Show that σ is strongly convex and simplicial.

1.2.11. Explain the picture illustrated in Figure 8 in terms of Proposition 1.2.8.

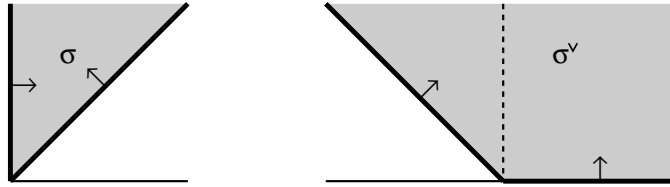

Figure 8. A cone σ in the plane and its dual

1.2.12. Let $P \subseteq N_{\mathbb{R}}$ be a polytope lying in an affine hyperplane (= translate of a hyperplane) not containing the origin. Generalize Figure 3 by showing that P gives a convex polyhedral cone in $N_{\mathbb{R}}$. Draw a picture.

1.2.13. Consider the cone $\sigma = \text{Cone}(3e_1 - 2e_2, e_1) \subseteq \mathbb{R}^2$.

- Describe σ^{\vee} and find generators of $\sigma^{\vee} \cap \mathbb{Z}^2$. Draw a picture similar to Figure 7.
- Compute the toric ideal of the affine toric variety U_{σ} and explain how this exercise relates to Exercise 1.1.6.

1.2.14. Consider the simplicial cone $\sigma = \text{Cone}(e_1, e_2, e_1 + e_2 + 2e_3) \subseteq \mathbb{R}^3$.

- Describe σ^{\vee} and find generators of $\sigma^{\vee} \cap \mathbb{Z}^3$.
- Compute the toric ideal of the affine toric variety U_{σ} .

1.2.15. Let σ be a strongly convex polyhedral cone of maximal dimension. Here is an example taken from [58, p. 132] to show that σ and σ^{\vee} need not have the same number of edges. Let $\sigma \subseteq \mathbb{R}^4$ be the cone generated by $2e_i + e_j$ for all $1 \leq i, j \leq 4, i \neq j$.

- Show that σ has 12 edges.
- Show that σ^{\vee} is generated by e_i and $-e_i + 2\sum_{j \neq i} e_j$, $1 \leq i \leq 4$ and has 8 edges.

§1.3. Properties of Affine Toric Varieties

The final task of this chapter is to explore the properties of affine toric varieties. We will also study maps between affine toric varieties.

Points of Affine Toric Varieties. We first consider various ways to describe the points of an affine toric variety.

Proposition 1.3.1. *Let $V = \text{Spec}(\mathbb{C}[S])$ be the affine toric variety of the affine semigroup S . Then there are bijective correspondences between the following:*

- (a) Points $p \in V$.
- (b) Maximal ideals $\mathfrak{m} \subseteq \mathbb{C}[S]$.
- (c) Semigroup homomorphisms $S \rightarrow \mathbb{C}$, where \mathbb{C} is considered as a semigroup under multiplication.

Proof. The correspondence between (a) and (b) is standard (see [35, Thm. 5 of Ch. 5, §4]). The correspondence between (a) and (c) is special to the toric case.

Given a point $p \in V$, define $S \rightarrow \mathbb{C}$ by sending $m \in S$ to $\chi^m(p) \in \mathbb{C}$. This makes sense since $\chi^m \in \mathbb{C}[S] = \mathbb{C}[V]$. One easily checks that $S \rightarrow \mathbb{C}$ is a semigroup homomorphism.

Going the other way, let $\gamma : S \rightarrow \mathbb{C}$ be a semigroup homomorphism. Since $\{\chi^m\}_{m \in S}$ is a basis of $\mathbb{C}[S]$, γ induces a surjective linear map $\mathbb{C}[S] \rightarrow \mathbb{C}$ which is a \mathbb{C} -algebra homomorphism. The kernel of the map $\mathbb{C}[S] \rightarrow \mathbb{C}$ is a maximal ideal and thus gives a point $p \in V$ by the correspondence between (a) and (b).

We construct p concretely as follows. Let $\mathcal{A} = \{m_1, \dots, m_s\}$ generate S , so that $V = Y_{\mathcal{A}} \subseteq \mathbb{C}^s$. Let $p = (\gamma(m_1), \dots, \gamma(m_s)) \in \mathbb{C}^s$. Let us prove that $p \in V$. By Proposition 1.1.9, it suffices to show that $x^\alpha - x^\beta$ vanishes at p for all exponent vectors $\alpha = (a_1, \dots, a_s)$ and $\beta = (b_1, \dots, b_s)$ satisfying

$$\sum_{i=1}^s a_i m_i = \sum_{i=1}^s b_i m_i.$$

This is easy, since γ being a semigroup homomorphism implies that

$$\prod_{i=1}^s \gamma(m_i)^{a_i} = \gamma\left(\sum_{i=1}^s a_i m_i\right) = \gamma\left(\sum_{i=1}^s b_i m_i\right) = \prod_{i=1}^s \gamma(m_i)^{b_i}.$$

It is straightforward to show that this point of V agrees with the one constructed in the previous paragraph (Exercise 1.3.1). \square

As an application of this result, we describe the torus action on V . In terms of the embedding $V = Y_{\mathcal{A}} \subseteq \mathbb{C}^s$, the proof of Proposition 1.1.8 shows that the action of T_N on $Y_{\mathcal{A}}$ is induced by the usual action of $(\mathbb{C}^*)^s$ on \mathbb{C}^s . But how do we see the action intrinsically, without embedding into affine space? This is where

semigroup homomorphisms prove their value. Fix $t \in T_N$ and $p \in V$, and let p correspond to the semigroup homomorphism $m \mapsto \gamma(m)$. In Exercise 1.3.1 you will show that $t \cdot p$ is given by the semigroup homomorphism $m \mapsto \chi^m(t)\gamma(m)$. This description will prove useful in Chapter 3 when we study torus orbits.

From the point of view of group actions, the action of T_N on V is given by a map $T_N \times V \rightarrow V$. Since both sides are affine varieties, this should be a morphism, meaning that it should come from a \mathbb{C} -algebra homomorphism

$$\mathbb{C}[S] = \mathbb{C}[V] \longrightarrow \mathbb{C}[T_N \times V] = \mathbb{C}[T_N] \otimes_{\mathbb{C}} \mathbb{C}[V] = \mathbb{C}[M] \otimes_{\mathbb{C}} \mathbb{C}[S].$$

This homomorphism is given by $\chi^m \mapsto \chi^m \otimes \chi^m$ for $m \in S$ (Exercise 1.3.2).

We can also characterize those affine toric varieties for which the torus action has a fixed point. We say that an affine semigroup S is *pointed* if $S \cap (-S) = \{0\}$, i.e., if 0 is the only element of S with an inverse. This is the semigroup analog of being strongly convex.

Proposition 1.3.2. *Let V be an affine toric variety. Then:*

- (a) *If we write $V = \text{Spec}(\mathbb{C}[S])$, then the torus action has a fixed point if and only if S is pointed, in which case the unique fixed point is given by the semigroup homomorphism $S \rightarrow \mathbb{C}$ defined by*

$$(1.3.1) \quad m \longmapsto \begin{cases} 1 & m = 0 \\ 0 & m \neq 0. \end{cases}$$

- (b) *If we write $V = Y_{\mathcal{A}} \subseteq \mathbb{C}^s$ for $\mathcal{A} \subseteq S \setminus \{0\}$, then the torus action has a fixed point if and only if $0 \in Y_{\mathcal{A}}$, in which case the unique fixed point is 0.*

Proof. For part (a), let $p \in V$ be represented by the semigroup homomorphism $\gamma : S \rightarrow \mathbb{C}$. Then p is fixed by the torus action if and only if $\chi^m(t)\gamma(m) = \gamma(m)$ for all $m \in S$ and $t \in T_N$. This equation is satisfied for $m = 0$ since $\gamma(0) = 1$, and if $m \neq 0$, then picking t with $\chi^m(t) \neq 0$ shows that $\gamma(m) = 0$. Thus, if a fixed point exists, then it is unique and is given by (1.3.1). Then we are done since (1.3.1) is a semigroup homomorphism if and only if S is pointed.

For part (b), first assume that $V = Y_{\mathcal{A}} \subseteq \mathbb{C}^s$ has a fixed point, in which case $S = \mathbb{N}\mathcal{A}$ is pointed and the unique point p is given by (1.3.1). Then $\mathcal{A} \subseteq S \setminus \{0\}$ and the proof of Proposition 1.3.1 imply that p is the origin in \mathbb{C}^s , so that $0 \in Y_{\mathcal{A}}$. The converse follows since $0 \in \mathbb{C}^s$ is fixed by $(\mathbb{C}^*)^s$ hence by $T_N \subseteq (\mathbb{C}^*)^s$. \square

Here is a useful corollary of Proposition 1.3.2 (Exercise 1.3.3).

Corollary 1.3.3. *Let U_{σ} be the affine toric variety of a strongly convex polyhedral cone $\sigma \subseteq N_{\mathbb{R}}$. Then the torus action on U_{σ} has a fixed point if and only if $\dim \sigma = \dim N_{\mathbb{R}}$, in which case the fixed point is unique and is given by the maximal ideal*

$$\langle \chi^m \mid m \in S_{\sigma} \setminus \{0\} \rangle \subseteq \mathbb{C}[S_{\sigma}],$$

where as usual $S_{\sigma} = \sigma^{\vee} \cap M$. \square

We will see in Chapter 3 that this corollary is part of the correspondence between torus orbits of U_σ and faces of σ .

Normality and Saturation. We next study the question of when an affine toric variety V is normal. We need one definition before stating our normality criterion.

Definition 1.3.4. An affine semigroup $S \subseteq M$ is **saturated** if for all $k \in \mathbb{N} \setminus \{0\}$ and $m \in M$, $km \in S$ implies $m \in S$.

For example, if $\sigma \subseteq N_{\mathbb{R}}$ is a strongly convex rational polyhedral cone, then $S_\sigma = \sigma^\vee \cap M$ is easily seen to be saturated (Exercise 1.3.4).

Theorem 1.3.5. *Let V be an affine toric variety with torus T_N . Then the following are equivalent:*

- (a) V is normal.
- (b) $V = \text{Spec}(\mathbb{C}[S])$, where $S \subseteq M$ is a saturated affine semigroup.
- (c) $V = \text{Spec}(\mathbb{C}[S_\sigma]) (= U_\sigma)$, where $S_\sigma = \sigma^\vee \cap M$ and $\sigma \subseteq N_{\mathbb{R}}$ is a strongly convex rational polyhedral cone.

Proof. By Theorem 1.1.17, $V = \text{Spec}(\mathbb{C}[S])$ for an affine semigroup S contained in a lattice, and by Proposition 1.1.14, the torus of V has the character lattice $M = \mathbb{Z}S$. Also let $n = \dim V$, so that $M \simeq \mathbb{Z}^n$.

(a) \Rightarrow (b): If V is normal, then $\mathbb{C}[S] = \mathbb{C}[V]$ is integrally closed in its field of fractions $\mathbb{C}(V)$. Suppose that $km \in S$ for some $k \in \mathbb{N} \setminus \{0\}$ and $m \in M$. Then χ^m is a polynomial function on T_N and hence a rational function on V since $T_N \subseteq V$ is Zariski open. We also have $\chi^{km} \in \mathbb{C}[S]$ since $km \in S$. It follows that χ^m is a root of the monic polynomial $X^k - \chi^{km}$ with coefficients in $\mathbb{C}[S]$. By the definition of normal, we obtain $\chi^m \in \mathbb{C}[S]$, i.e., $m \in S$. Thus S is saturated.

(b) \Rightarrow (c): Let $\mathcal{A} \subseteq S$ be a finite generating set of S . Then S lies in the rational polyhedral cone $\text{Cone}(\mathcal{A}) \subseteq M_{\mathbb{R}}$, and $\text{rank } \mathbb{Z}\mathcal{A} = n$ implies $\dim \text{Cone}(\mathcal{A}) = n$ by Exercise 1.2.6. It follows that $\sigma = \text{Cone}(\mathcal{A})^\vee \subseteq N_{\mathbb{R}}$ is a strongly convex rational polyhedral cone such that $S \subseteq \sigma^\vee \cap M$. In Exercise 1.3.4 you will prove that equality holds when S is saturated. Hence $S = S_\sigma$.

(c) \Rightarrow (a): We need to show that $\mathbb{C}[S_\sigma] = \mathbb{C}[\sigma^\vee \cap M]$ is normal when $\sigma \subseteq N_{\mathbb{R}}$ is a strongly convex rational polyhedral cone. Let ρ_1, \dots, ρ_r be the rays of σ . Since σ is generated by its rays (Lemma 1.2.15), we have

$$\sigma^\vee = \bigcap_{i=1}^r \rho_i^\vee.$$

Intersecting with M gives $S_\sigma = \bigcap_{i=1}^r S_{\rho_i}$, which easily implies

$$\mathbb{C}[S_\sigma] = \bigcap_{i=1}^r \mathbb{C}[S_{\rho_i}].$$

By Exercise 1.0.7, $\mathbb{C}[S_\sigma]$ is normal if each $\mathbb{C}[S_{\rho_i}]$ is normal, so it suffices to prove that $\mathbb{C}[S_\rho]$ is normal when ρ is a rational ray in $N_{\mathbb{R}}$. Let $u_\rho \in \rho \cap N$ be the ray generator of ρ . Since u is primitive, i.e., $\frac{1}{k}u_\rho \notin N$ for all $k > 1$, we can find a basis e_1, \dots, e_n of N with $u_\rho = e_1$ (Exercise 1.3.5). This allows us to assume that $\rho = \text{Cone}(e_1)$, so that

$$\mathbb{C}[S_\rho] = \mathbb{C}[x_1, x_2^{\pm 1}, \dots, x_n^{\pm 1}]$$

by Example 1.2.20. But $\mathbb{C}[x_1, \dots, x_n]$ is normal (it is a UFD), so its localization

$$\mathbb{C}[x_1, \dots, x_n]_{x_2 \cdots x_n} = \mathbb{C}[x_1, x_2^{\pm 1}, \dots, x_n^{\pm 1}]$$

is also normal by Exercise 1.0.7. This completes the proof. \square

Example 1.3.6. We saw in Example 1.2.19 that $V = \mathbf{V}(xy - zw)$ is the affine toric variety U_σ of the cone $\sigma = \text{Cone}(e_1, e_2, e_1 + e_3, e_2 + e_3)$ pictured in Figure 1. Then Theorem 1.3.5 implies that V is normal, as claimed in Example 1.1.5. \diamond

Example 1.3.7. By Example 1.2.21, the rational normal cone $\widehat{C}_d \subseteq \mathbb{C}^{d+1}$ is the affine toric variety of a strongly convex rational polyhedral cone and hence is normal by Theorem 1.3.5.

It is instructive to view this example using the parametrization

$$\Phi_{\mathcal{A}}(s, t) = (s^d, s^{d-1}t, \dots, st^{d-1}, t^d)$$

from Example 1.1.6. Plotting the lattice points in \mathcal{A} for $d = 2$ gives the white squares in Figure 9 (a) below. These generate the semigroup $S = \mathbb{N}\mathcal{A}$, and the proof of Theorem 1.3.5 gives the cone $\sigma^\vee = \text{Cone}(e_1, e_2)$, which is the first quadrant in the figure. At first glance, something seems wrong. The affine variety \widehat{C}_2 is normal, yet in Figure 9 (a) the semigroup generated by the white squares misses some lattice points in σ^\vee . This semigroup does not look saturated. How can the affine toric variety be normal?

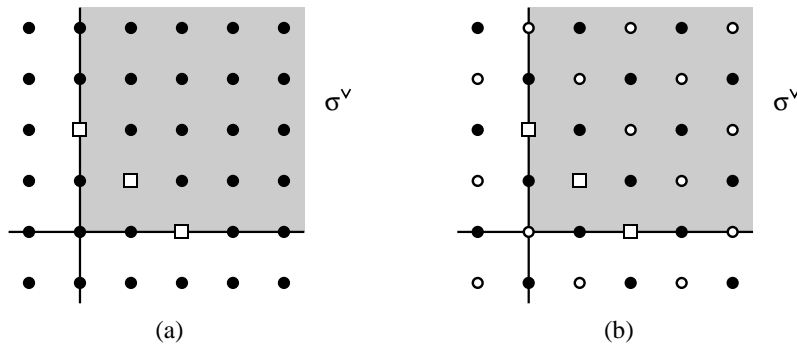

Figure 9. Lattice points for the rational normal cone \widehat{C}_2

The problem is that we are using the wrong lattice! Proposition 1.1.8 tells us to use the lattice $\mathbb{Z}\mathcal{A}$, which gives the white dots and squares in Figure 9 (b). This

figure shows that the white squares generate the semigroup of lattice points in σ^\vee . Hence S is saturated and everything is fine. \diamond

This example points out the importance of working with the correct lattice.

The Normalization of an Affine Toric Variety. The normalization of an affine toric variety is easy to describe. Let $V = \text{Spec}(\mathbb{C}[S])$ for an affine semigroup S , so that the torus of V has character lattice $M = \mathbb{Z}S$. Let $\text{Cone}(S)$ denote the cone of any finite generating set of S and set $\sigma = \text{Cone}(S)^\vee \subseteq N_{\mathbb{R}}$. In Exercise 1.3.6 you will prove the following.

Proposition 1.3.8. *The above cone σ is a strongly convex rational polyhedral cone in $N_{\mathbb{R}}$ and the inclusion $\mathbb{C}[S] \subseteq \mathbb{C}[\sigma^\vee \cap M]$ induces a morphism $U_\sigma \rightarrow V$ that is the normalization map of V . \square*

The normalization of an affine toric variety of the form $Y_{\mathcal{A}}$ is constructed by applying Proposition 1.3.8 to the affine semigroup $\mathbb{N}\mathcal{A}$ and the lattice $\mathbb{Z}\mathcal{A}$.

Example 1.3.9. Let $\mathcal{A} = \{(4, 0), (3, 1), (1, 3), (0, 4)\} \subseteq \mathbb{Z}^2$. Then

$$\Phi_{\mathcal{A}}(s, t) = (s^4, s^3t, st^3, t^4)$$

parametrizes the surface $Y_{\mathcal{A}} \subseteq \mathbb{C}^4$ considered in Exercise 1.1.7. This is almost the rational normal cone \widehat{C}_4 , except that we have omitted s^2t^2 . Using $(2, 2) = \frac{1}{2}((4, 0) + (0, 4))$, we see that $\mathbb{N}\mathcal{A}$ is not saturated, so that $Y_{\mathcal{A}}$ is not normal.

Applying Proposition 1.3.8, one sees that the normalization of $Y_{\mathcal{A}}$ is \widehat{C}_4 . This is an affine variety in \mathbb{C}^5 , and the normalization map is induced by the obvious projection $\mathbb{C}^5 \rightarrow \mathbb{C}^4$. \diamond

Proposition 1.3.8 can be interpreted as saying that $\sigma^\vee \cap M$ is the *saturation* of the semigroup S . Saturations can be computed using Normaliz [27].

In Chapter 3 we will see that the normalization map $U_\sigma \rightarrow V$ constructed in Proposition 1.3.8 is onto but not necessarily one-to-one.

Smooth Affine Toric Varieties. Our next goal is to characterize when an affine toric variety is smooth. Since smooth affine varieties are normal (Proposition 1.0.9), we need only consider toric varieties U_σ coming from strongly convex rational polyhedral cones $\sigma \subseteq N_{\mathbb{R}}$.

We first study U_σ when σ has maximal dimension. Then σ^\vee is strongly convex, so that $S_\sigma = \sigma^\vee \cap M$ has a Hilbert basis \mathcal{H} . Furthermore, Corollary 1.3.3 tells us that the torus action on U_σ has a unique fixed point, denoted here by $p_\sigma \in U_\sigma$. The point p_σ and the Hilbert basis \mathcal{H} are related as follows.

Lemma 1.3.10. *Let $\sigma \subseteq N_{\mathbb{R}}$ be a strongly convex rational polyhedral cone of maximal dimension and let $T_{p_\sigma}(U_\sigma)$ be the Zariski tangent space to the affine toric variety U_σ at the above point p_σ . Then $\dim T_{p_\sigma}(U_\sigma) = |\mathcal{H}|$.*

Proof. By Corollary 1.3.3, the maximal ideal of $\mathbb{C}[\mathbb{S}_\sigma]$ corresponding to p_σ is $\mathfrak{m} = \langle \chi^m \mid m \in \mathbb{S}_\sigma \setminus \{0\} \rangle$. Since $\{\chi^m\}_{m \in \mathbb{S}_\sigma}$ is a basis of $\mathbb{C}[\mathbb{S}_\sigma]$, we obtain

$$\mathfrak{m} = \bigoplus_{m \neq 0} \mathbb{C}\chi^m = \bigoplus_{m \text{ irreducible}} \mathbb{C}\chi^m \oplus \bigoplus_{m \text{ reducible}} \mathbb{C}\chi^m = \left(\bigoplus_{m \in \mathcal{H}} \mathbb{C}\chi^m \right) \oplus \mathfrak{m}^2.$$

It follows that $\dim \mathfrak{m}/\mathfrak{m}^2 = |\mathcal{H}|$. To relate this to the maximal ideal $\mathfrak{m}_{U_\sigma, p_\sigma}$ in the local ring $\mathcal{O}_{U_\sigma, p_\sigma}$, we use the natural map

$$\mathfrak{m}/\mathfrak{m}^2 \longrightarrow \mathfrak{m}_{U_\sigma, p_\sigma}/\mathfrak{m}_{U_\sigma, p_\sigma}^2$$

which is always an isomorphism (Exercise 1.3.7). Since $T_{p_\sigma}(U_\sigma)$ is the dual space of $\mathfrak{m}_{U_\sigma, p_\sigma}/\mathfrak{m}_{U_\sigma, p_\sigma}^2$, we see that $\dim T_{p_\sigma}(U_\sigma) = |\mathcal{H}|$. \square

The Hilbert basis \mathcal{H} of \mathbb{S}_σ gives $U_\sigma = Y_{\mathcal{H}} \subseteq \mathbb{C}^s$, where $s = |\mathcal{H}|$. This affine embedding is especially nice. Given *any* affine embedding $U_\sigma \hookrightarrow \mathbb{C}^\ell$, we have $\dim T_{p_\sigma}(U_\sigma) \leq \ell$ by Lemma 1.0.6. In other words, $\dim T_{p_\sigma}(U_\sigma)$ is a lower bound on the dimension of an affine embedding. Then Lemma 1.3.10 shows that when σ has maximal dimension, the Hilbert basis of \mathbb{S}_σ gives the most efficient affine embedding of U_σ .

Example 1.3.11. In Example 1.2.21, we saw that the rational normal cone $\widehat{C}_d \subseteq \mathbb{C}^{d+1}$ is the toric variety coming from $\sigma = \text{Cone}(de_1 - e_2, e_2) \subseteq \mathbb{R}^2$ and that $\mathbb{S}_\sigma = \sigma^\vee \cap \mathbb{Z}^2$ is generated by $(1, i)$ for $0 \leq i \leq d$. These generators form the Hilbert basis of \mathbb{S}_σ , so that the Zariski tangent space of $0 \in \widehat{C}_d$ has dimension $d+1$. Hence \mathbb{C}^{d+1} is the smallest affine space in which we can embed \widehat{C}_d . \diamond

We now come to our main result about smoothness. Recall from §1.2 that a rational polyhedral cone is *smooth* if it can be generated by a subset of a basis of the lattice.

Theorem 1.3.12. *Let $\sigma \subseteq N_{\mathbb{R}}$ be a strongly convex rational polyhedral cone. Then U_σ is smooth if and only if σ is smooth. Furthermore, all smooth affine toric varieties are of this form.*

Proof. If an affine toric variety is smooth, then it is normal by Proposition 1.0.9 and hence of the form U_σ . Also, Example 1.2.20 implies that if σ is smooth as a cone, then U_σ is smooth as a variety. It remains to prove the converse. So fix $\sigma \subseteq N_{\mathbb{R}}$ such that U_σ is smooth. Let $n = \dim U_\sigma = \dim N_{\mathbb{R}}$.

First suppose that σ has dimension n and let $p_\sigma \in U_\sigma$ be the point studied in Lemma 1.3.10. Since p_σ is smooth in U_σ , the Zariski tangent space $T_{p_\sigma}(U_\sigma)$ has dimension n by Definition 1.0.7. On the other hand, Lemma 1.3.10 implies that $\dim T_{p_\sigma}(U_\sigma)$ is the cardinality of the Hilbert basis \mathcal{H} of $\mathbb{S}_\sigma = \sigma^\vee \cap M$. Thus

$$n = |\mathcal{H}| \geq |\{\text{edges } \rho \subseteq \sigma^\vee\}| \geq n,$$

where the first inequality holds by Proposition 1.2.22 (each edge $\rho \subseteq \sigma^\vee$ contributes an element of \mathcal{H}) and the second holds since $\dim \sigma^\vee = n$. It follows that σ

has n edges and \mathcal{H} consists of the ray generators of these edges. Since $M = \mathbb{Z}S_\sigma$ by (1.2.3), the n edge generators of σ^\vee generate the lattice $M \simeq \mathbb{Z}^n$ and hence form a basis of M . Thus σ^\vee is smooth, and then $\sigma = (\sigma^\vee)^\vee$ is smooth since duality preserves smoothness.

Next suppose $\dim \sigma = r < n$. We reduce to the previous case as follows. Let $N_1 \subseteq N$ be the smallest saturated sublattice containing the generators of σ . Then N/N_1 is torsion-free, which by Exercise 1.3.5 implies the existence of a sublattice $N_2 \subseteq N$ with $N = N_1 \oplus N_2$. Note $\text{rank } N_1 = r$ and $\text{rank } N_2 = n - r$.

The cone σ lies in both $(N_1)_\mathbb{R}$ and $N_\mathbb{R}$. This gives affine toric varieties U_{σ, N_1} and $U_{\sigma, N}$ of dimensions r and n respectively. Furthermore, $N = N_1 \oplus N_2$ induces $M = M_1 \oplus M_2$, so that $\sigma \subseteq (N_1)_\mathbb{R}$ and $\sigma \subseteq N_\mathbb{R}$ give the affine semigroups $S_{\sigma, N_1} \subseteq M_1$ and $S_{\sigma, N} \subseteq M$ respectively. It is straightforward to show that

$$S_{\sigma, N} = S_{\sigma, N_1} \oplus M_2,$$

which in terms of semigroup algebras can be written

$$\mathbb{C}[S_{\sigma, N}] \simeq \mathbb{C}[S_{\sigma, N_1}] \otimes_{\mathbb{C}} \mathbb{C}[M_2].$$

The right-hand side is the coordinate ring of $U_{\sigma, N_1} \times T_{N_2}$. Thus

$$(1.3.2) \quad U_{\sigma, N} \simeq U_{\sigma, N_1} \times T_{N_2},$$

which in turn implies that

$$U_{\sigma, N} \simeq U_{\sigma, N_1} \times (\mathbb{C}^*)^{n-r} \subseteq U_{\sigma, N_1} \times \mathbb{C}^{n-r}.$$

Since we are assuming that $U_{\sigma, N}$ is smooth, it follows that $U_{\sigma, N_1} \times \mathbb{C}^{n-r}$ is smooth at any point (p, q) in $U_{\sigma, N_1} \times (\mathbb{C}^*)^{n-r}$. In Exercise 1.3.8 you will show that

$$(1.3.3) \quad U_{\sigma, N_1} \times \mathbb{C}^{n-r} \text{ is smooth at } (p, q) \implies U_{\sigma, N_1} \text{ is smooth at } p.$$

Letting $p = p_\sigma \in U_{\sigma, N_1}$, the previous case implies that σ is smooth in N_1 since $\dim \sigma = \dim (N_1)_\mathbb{R}$. Hence σ is clearly smooth in $N = N_1 \oplus N_2$. \square

Equivariant Maps between Affine Toric Varieties. We next study maps $V_1 \rightarrow V_2$ between affine toric varieties that respect the torus actions on V_1 and V_2 .

Definition 1.3.13. Let $V_i = \text{Spec}(\mathbb{C}[S_i])$ be the affine toric varieties coming from the affine semigroups S_i , $i = 1, 2$. Then a morphism $\phi : V_1 \rightarrow V_2$ is **toric** if the corresponding map of coordinate rings $\phi^* : \mathbb{C}[S_2] \rightarrow \mathbb{C}[S_1]$ is induced by a semigroup homomorphism $\hat{\phi} : S_2 \rightarrow S_1$.

Here is our first result concerning toric morphisms.

Proposition 1.3.14. Let T_{N_i} be the torus of the affine toric variety V_i , $i = 1, 2$.

(a) A morphism $\phi : V_1 \rightarrow V_2$ is toric if and only if

$$\phi(T_{N_1}) \subseteq T_{N_2}$$

and $\phi|_{T_{N_1}} : T_{N_1} \rightarrow T_{N_2}$ is a group homomorphism.

(b) A toric morphism $\phi : V_1 \rightarrow V_2$ is **equivariant**, meaning that

$$\phi(t \cdot p) = \phi(t) \cdot \phi(p)$$

for all $t \in T_{N_1}$ and $p \in V_1$.

Proof. Let $V_i = \text{Spec}(\mathbb{C}[S_i])$, so that the character lattice of T_{N_i} is $M_i = \mathbb{Z}S_i$. If ϕ comes from a semigroup homomorphism $\widehat{\phi} : S_2 \rightarrow S_1$, then $\widehat{\phi}$ extends to a group homomorphism $\widehat{\phi} : M_2 \rightarrow M_1$ and hence gives a commutative diagram

$$\begin{array}{ccc} \mathbb{C}[S_2] & \xrightarrow{\phi^*} & \mathbb{C}[S_1] \\ \downarrow & & \downarrow \\ \mathbb{C}[M_2] & \longrightarrow & \mathbb{C}[M_1]. \end{array}$$

Applying Spec , we see that $\phi(T_{N_1}) \subseteq T_{N_2}$, and $\phi|_{T_{N_1}} : T_{N_1} \rightarrow T_{N_2}$ is a group homomorphism since $T_{N_i} = \text{Hom}_{\mathbb{Z}}(M_i, \mathbb{C}^*)$ by Exercise 1.1.11. Conversely, if ϕ satisfies these conditions, then $\phi|_{T_{N_1}} : T_{N_1} \rightarrow T_{N_2}$ induces a diagram as above where the bottom map comes from a group homomorphism $\widehat{\phi} : M_2 \rightarrow M_1$. This, combined with $\phi^*(\mathbb{C}[S_2]) \subseteq \mathbb{C}[S_1]$, implies that $\widehat{\phi}$ induces a semigroup homomorphism $\widehat{\phi} : S_2 \rightarrow S_1$. This proves part (a) of the proposition.

For part (b), suppose that we have a toric map $\phi : V_1 \rightarrow V_2$. The action of T_{N_i} on V_i is given by a morphism $\Phi_i : T_{N_i} \times V_i \rightarrow V_i$, and equivariance means that we have a commutative diagram

$$\begin{array}{ccc} T_{N_1} \times V_1 & \xrightarrow{\Phi_1} & V_1 \\ \phi|_{T_{N_1}} \times \phi \downarrow & & \downarrow \phi \\ T_{N_2} \times V_2 & \xrightarrow{\Phi_2} & V_2. \end{array}$$

If we replace V_i with T_{N_i} in the diagram, then it certainly commutes since $\phi|_{T_{N_1}}$ is a group homomorphism. Then the whole diagram commutes since $T_{N_1} \times T_{N_1}$ is Zariski dense in $T_{N_1} \times V_1$. \square

We can also characterize toric morphisms between affine toric varieties coming from strongly convex rational polyhedral cones. First note that a homomorphism $\overline{\phi} : N_1 \rightarrow N_2$ of lattices gives a group homomorphism $\phi : T_{N_1} \rightarrow T_{N_2}$ of tori. This follows from $T_{N_i} = N_i \otimes_{\mathbb{Z}} \mathbb{C}^*$, and one sees that ϕ is a morphism. Also, tensoring $\overline{\phi}$ with \mathbb{R} gives $\overline{\phi}_{\mathbb{R}} : (N_1)_{\mathbb{R}} \rightarrow (N_2)_{\mathbb{R}}$.

Here is the result, whose proof we leave to the reader (Exercise 1.3.9).

Proposition 1.3.15. *Suppose we have strongly convex rational polyhedral cones $\sigma_i \subseteq (N_i)_{\mathbb{R}}$ and a homomorphism $\overline{\phi} : N_1 \rightarrow N_2$. Then $\phi : T_{N_1} \rightarrow T_{N_2}$ extends to a map of affine toric varieties $\phi : U_{\sigma_1} \rightarrow U_{\sigma_2}$ if and only if $\overline{\phi}_{\mathbb{R}}(\sigma_1) \subseteq \sigma_2$. \square*

In the remainder of the chapter we explore some interesting classes of toric morphisms.

Faces and Affine Open Subsets. Let $\sigma \subseteq N_{\mathbb{R}}$ be a strongly convex rational polyhedral cone and let $\tau \preceq \sigma$ be a face. Then we can find $m \in \sigma^{\vee} \cap M$ such that $\tau = H_m \cap \sigma$. This allows us to relate semigroup algebras of σ and τ as follows.

Proposition 1.3.16. *Let τ be a face of σ and as above write $\tau = H_m \cap \sigma$, where $m \in \sigma^{\vee} \cap M$. Then the semigroup algebra $\mathbb{C}[S_{\tau}] = \mathbb{C}[\tau^{\vee} \cap M]$ is the localization of $\mathbb{C}[S_{\sigma}] = \mathbb{C}[\sigma^{\vee} \cap M]$ at $\chi^m \in \mathbb{C}[S_{\sigma}]$. In other words,*

$$\mathbb{C}[S_{\tau}] = \mathbb{C}[S_{\sigma}]_{\chi^m}.$$

Proof. The inclusion $\tau \subseteq \sigma$ implies $S_{\sigma} \subset S_{\tau}$, and since $\langle m, u \rangle = 0$ for all $u \in \tau$, we have $\pm m \in \tau^{\vee}$. It follows that

$$S_{\sigma} + \mathbb{Z}(-m) \subseteq S_{\tau}.$$

This inclusion is actually an equality, as we now prove. Fix a finite set $S \subseteq N$ with $\sigma = \text{Cone}(S)$ and pick $m' \in S_{\tau}$. Set

$$C = \max_{u \in S} \{|\langle m', u \rangle|\} \in \mathbb{N}.$$

It is straightforward to show that $m' + Cm \in S_{\sigma}$. This proves that

$$S_{\sigma} + \mathbb{Z}(-m) = S_{\tau},$$

from which $\mathbb{C}[S_{\tau}] = \mathbb{C}[S_{\sigma}]_{\chi^m}$ follows immediately. \square

This interprets nicely in terms of toric morphisms. By Proposition 1.3.15, the identity map $N \rightarrow N$ and the inclusion $\tau \subseteq \sigma$ give the toric morphism $U_{\tau} \rightarrow U_{\sigma}$ that corresponds to the inclusion $\mathbb{C}[S_{\sigma}] \subseteq \mathbb{C}[S_{\tau}]$. By Proposition 1.3.16,

$$(1.3.4) \quad U_{\tau} = \text{Spec}(\mathbb{C}[S_{\tau}]) = \text{Spec}(\mathbb{C}[S_{\sigma}]_{\chi^m}) = \text{Spec}(\mathbb{C}[S_{\sigma}])_{\chi^m} = (U_{\sigma})_{\chi^m} \subseteq U_{\sigma}.$$

In other words, U_{τ} becomes an affine open subset of U_{σ} when $\tau \preceq \sigma$. This will be useful in Chapters 2 and 3 when we study the local structure of more general toric varieties.

Sublattices of Finite Index and Rings of Invariants. Another interesting class of toric morphisms arises when we keep the same cone but change the lattice. Here is an example we have already seen.

Example 1.3.17. In Example 1.3.7 the dual of $\sigma = \text{Cone}(e_1, e_2) \subseteq \mathbb{R}^2$ interacts with the lattices shown in Figure 10 on the next page. To make this precise, let us name the lattices involved: the lattices

$$N' = \mathbb{Z}^2 \subseteq N = \{(a/2, b/2) \mid a, b \in \mathbb{Z}, a + b \equiv 0 \pmod{2}\}$$

have $\sigma \subseteq N'_{\mathbb{R}} \subseteq N_{\mathbb{R}}$, and the dual lattices

$$M' = \mathbb{Z}^2 \supseteq M = \{(a, b) \mid a, b \in \mathbb{Z}, a + b \equiv 0 \pmod{2}\}$$

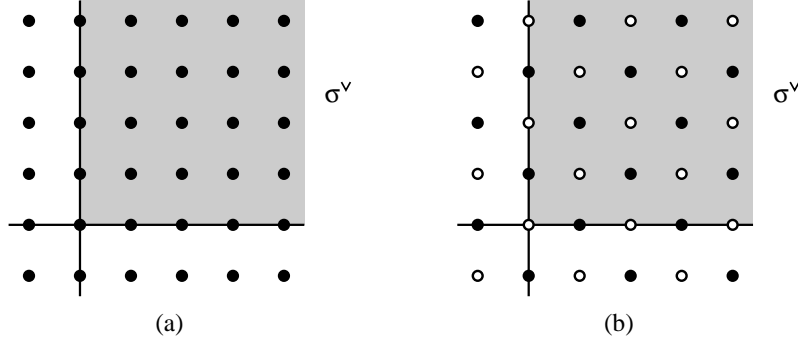

Figure 10. Lattice points of σ^\vee relative to two lattices

have $\sigma^\vee \subseteq M'_\mathbb{R} \subseteq M_\mathbb{R}$. Note that duality reverses inclusions and that M and N are indeed dual under dot product. In Figure 10 (a), the black dots in the first quadrant form the semigroup $S_{\sigma, N'} = \sigma^\vee \cap M'$, and in Figure 10 (b), the white dots in the first quadrant form $S_{\sigma, N} = \sigma^\vee \cap M$.

This gives the affine toric varieties $U_{\sigma, N'}$ and $U_{\sigma, N}$. Clearly $U_{\sigma, N'} = \mathbb{C}^2$ since σ is smooth for N' , while Example 1.3.7 shows that $U_{\sigma, N}$ is the rational normal cone $\widehat{\mathcal{C}}_2$. The inclusion $N' \subseteq N$ gives a toric morphism

$$\mathbb{C}^2 = U_{\sigma, N'} \longrightarrow U_{\sigma, N} = \widehat{\mathcal{C}}_2.$$

Our next task is to find a nice description of this map. \diamond

In general, suppose we have lattices $N' \subseteq N$, where N' has finite index in N , and let $\sigma \subseteq N'_\mathbb{R} = N_\mathbb{R}$ be a strongly convex rational polyhedral cone. Then the inclusion $N' \subseteq N$ gives the toric morphism

$$\phi : U_{\sigma, N'} \longrightarrow U_{\sigma, N}.$$

The dual lattices satisfy $M' \supseteq M$, so that ϕ corresponds to the inclusion

$$\mathbb{C}[\sigma^\vee \cap M'] \supseteq \mathbb{C}[\sigma^\vee \cap M]$$

of semigroup algebras. The idea is to realize $\mathbb{C}[\sigma^\vee \cap M]$ as a ring of invariants of a group action on $\mathbb{C}[\sigma^\vee \cap M']$.

Proposition 1.3.18. *Let N' have finite index in N with quotient $G = N/N'$ and let $\sigma \subseteq N'_\mathbb{R} = N_\mathbb{R}$ be a strongly convex rational polyhedral cone. Then:*

(a) *There are natural isomorphisms*

$$G \simeq \text{Hom}_\mathbb{Z}(M'/M, \mathbb{C}^*) = \ker(T_{N'} \rightarrow T_N).$$

(b) *G acts on $\mathbb{C}[\sigma^\vee \cap M']$ with ring of invariants*

$$\mathbb{C}[\sigma^\vee \cap M']^G = \mathbb{C}[\sigma^\vee \cap M].$$

(c) G acts on $U_{\sigma, N'}$, and the morphism $\phi : U_{\sigma, N'} \rightarrow U_{\sigma, N}$ is constant on G -orbits and induces a bijection

$$U_{\sigma, N'} / G \simeq U_{\sigma, N}.$$

Proof. Since $T_N = \text{Hom}_{\mathbb{Z}}(M, \mathbb{C}^*)$ by Exercise 1.1.11, applying $\text{Hom}_{\mathbb{Z}}(-, \mathbb{C}^*)$ to

$$0 \longrightarrow M \longrightarrow M' \longrightarrow M'/M \longrightarrow 0$$

gives the sequence

$$1 \longrightarrow \text{Hom}_{\mathbb{Z}}(M'/M, \mathbb{C}^*) \longrightarrow T_{N'} \longrightarrow T_N \longrightarrow 1.$$

This is exact since $\text{Hom}_{\mathbb{Z}}(-, \mathbb{C}^*)$ is left exact and \mathbb{C}^* is divisible. To bring $G = N/N'$ into the picture, note that

$$N' \subseteq N \subseteq N_{\mathbb{Q}} \quad \text{and} \quad M \subseteq M' \subseteq M_{\mathbb{Q}}.$$

Since the pairing between M and N induces a pairing $M_{\mathbb{Q}} \times N_{\mathbb{Q}} \rightarrow \mathbb{Q}$, the map

$$M'/M \times N/N' \longrightarrow \mathbb{C}^* \quad ([m'], [u]) \longmapsto e^{2\pi i(m', u)}$$

is well-defined and induces $G \simeq \text{Hom}_{\mathbb{Z}}(M'/M, \mathbb{C}^*)$ (Exercise 1.3.10).

The action of $T_{N'}$ on $U_{\sigma, N'}$ induces an action of G on $U_{\sigma, N'}$ since $G \subseteq T_{N'}$. Using Exercise 1.3.1, one sees that if $g \in G$ and $\gamma \in U_{\sigma, N'}$, then $g \cdot \gamma$ is defined by the semigroup homomorphism $m' \mapsto g([m'])\gamma(m')$ for $m' \in \sigma^{\vee} \cap M'$. It follows that the corresponding action on the coordinate ring is given by

$$g \cdot \chi^{m'} = g([m'])^{-1} \chi^{m'}, \quad m' \in \sigma^{\vee} \cap M'.$$

(Exercise 5.0.1 explains why we need the inverse.) Since $m' \in M'$ lies in M if and only if $g([m']) = 1$ for all $g \in G$, the ring of invariants

$$\mathbb{C}[\sigma^{\vee} \cap M']^G = \{f \in \mathbb{C}[\sigma^{\vee} \cap M'] \mid g \cdot f = f \text{ for all } g \in G\},$$

is precisely $\mathbb{C}[\sigma^{\vee} \cap M]$, i.e.,

$$\mathbb{C}[\sigma^{\vee} \cap M']^G = \mathbb{C}[\sigma^{\vee} \cap M].$$

This proves part (b).

When a finite group G acts algebraically on \mathbb{C}^n , [35, Thm. 10 of Ch. 7, §4] shows that the ring of invariants $\mathbb{C}[x_1, \dots, x_n]^G \subseteq \mathbb{C}[x_1, \dots, x_n]$ gives a morphism of affine varieties

$$\mathbb{C}^n = \text{Spec}(\mathbb{C}[x_1, \dots, x_n]) \longrightarrow \text{Spec}(\mathbb{C}[x_1, \dots, x_n]^G)$$

that is constant on G -orbits and induces a bijection

$$\mathbb{C}^n / G \simeq \text{Spec}(\mathbb{C}[x_1, \dots, x_n]^G).$$

The proof extends without difficulty to the case when G acts algebraically on $V = \text{Spec}(R)$. Here, $R^G \subseteq R$ gives a morphism of affine varieties

$$V = \text{Spec}(R) \longrightarrow \text{Spec}(R^G)$$

that is constant on G -orbits and induces a bijection

$$V/G \simeq \text{Spec}(R^G).$$

From here, part (c) follows immediately from part (b). \square

We will give a careful treatment of these ideas in §5.0, where we will show that the map $\text{Spec}(R) \rightarrow \text{Spec}(R^G)$ is a *geometric quotient*.

Here are some examples of Proposition 1.3.18.

Example 1.3.19. In the situation of Example 1.3.17, one computes that G is the group $\mu_2 = \{\pm 1\}$ acting on $U_{\sigma, N'} = \text{Spec}(\mathbb{C}[s, t]) \simeq \mathbb{C}^2$ by $-1 \cdot (s, t) = (-s, -t)$. Thus the rational normal cone \widehat{C}_2 is the quotient

$$\mathbb{C}^2/\mu_2 = U_{\sigma, N'}/\mu_2 \simeq U_{\sigma, N} = \widehat{C}_2.$$

We can see this explicitly as follows. The invariant ring is easily seen to be

$$\mathbb{C}[s, t]^{\mu_2} = \mathbb{C}[s^2, st, t^2] = \mathbb{C}[\widehat{C}_2] \simeq \mathbb{C}[x_0, x_1, x_2]/\langle x_0x_2 - x_1^2 \rangle,$$

where the last isomorphism follows from Example 1.1.6. From the point of view of invariant theory, the generators s^2, st, t^2 of the ring of invariants give a morphism

$$\Phi : \mathbb{C}^2 \longrightarrow \mathbb{C}^3, \quad (s, t) \longrightarrow (s^2, st, t^2)$$

that is constant on μ_2 -orbits. This map also separates orbits, so it induces

$$\mathbb{C}^2/\mu_2 \simeq \Phi(\mathbb{C}^2) = \widehat{C}_2,$$

where the last equality is by Example 1.1.6. But we can also think about this in terms of semigroups, where the exponent vectors of s^2, st, t^2 give the Hilbert basis of the semigroup $S_{\sigma, N}$ pictured in Figure 10 (b). Everything fits together very nicely. \diamond

In Exercise 1.3.11 you will generalize Example 1.3.19 to the case of the rational normal cone \widehat{C}_d for arbitrary d .

Example 1.3.20. Let $\sigma \subseteq N_{\mathbb{R}} \simeq \mathbb{R}^n$ be a simplicial cone of dimension n with ray generators u_1, \dots, u_n . Then $N' = \sum_{i=1}^n \mathbb{Z}u_i$ is a sublattice of finite index in N . Furthermore, σ is smooth relative to N' , so that $U_{\sigma, N'} = \mathbb{C}^n$. It follows that $G = N/N'$ acts on \mathbb{C}^n with quotient

$$\mathbb{C}^n/G = U_{\sigma, N'}/G \simeq U_{\sigma, N}.$$

Hence the affine toric variety of a simplicial cone is the quotient of affine space by a finite abelian group. In the literature, varieties like $U_{\sigma, N}$ are called *orbifolds* and are said to be \mathbb{Q} -factorial. \diamond

Exercises for §1.3.

1.3.1. Consider the affine toric variety $Y_{\mathcal{A}} = \text{Spec}(\mathbb{C}[S])$, where $\mathcal{A} = \{m_1, \dots, m_s\}$ and $S = \mathbb{N}\mathcal{A}$. Let $\gamma : S \rightarrow \mathbb{C}$ be a semigroup homomorphism. In the proof of Proposition 1.3.1 we showed that $p = (\gamma(m_1), \dots, \gamma(m_s))$ lies in $Y_{\mathcal{A}}$.

- (a) Prove that the maximal ideal $\{f \in \mathbb{C}[S] \mid f(p) = 0\}$ is the kernel of the \mathbb{C} -algebra homomorphism $\mathbb{C}[S] \rightarrow \mathbb{C}$ induced by γ .
- (b) The torus T_N of $Y_{\mathcal{A}}$ has character lattice $M = \mathbb{Z}\mathcal{A}$ and fix $t \in T_N$. As in the discussion following Proposition 1.3.1, this gives the semigroup homomorphism $m \mapsto \chi^m(t)\gamma(m)$. Prove that this corresponds to the point

$$(\chi^{m_1}, \dots, \chi^{m_s}) \cdot (\gamma(m_1), \dots, \gamma(m_s)) = (\chi^{m_1}\gamma(m_1), \dots, \chi^{m_s}\gamma(m_s))$$

coming from the action of $t \in T_N \subseteq (\mathbb{C}^*)^s$ on $p \in Y_{\mathcal{A}} \subseteq \mathbb{C}^s$.

1.3.2. Let $V = \text{Spec}(\mathbb{C}[S])$ with $T_N = \text{Spec}(\mathbb{C}[M])$, $M = \mathbb{Z}S$. The action $T_N \times V \rightarrow V$ comes from a \mathbb{C} -algebra homomorphism $\mathbb{C}[S] \rightarrow \mathbb{C}[M] \otimes_{\mathbb{C}} \mathbb{C}[S]$. Prove that this homomorphism is given by $\chi^m \mapsto \chi^m \otimes \chi^m$. Hint: Show that this formula determines the \mathbb{C} -algebra homomorphism $\mathbb{C}[M] \rightarrow \mathbb{C}[M] \otimes_{\mathbb{C}} \mathbb{C}[M]$ that gives the group operation $T_N \times T_N \rightarrow T_N$.

1.3.3. Prove Corollary 1.3.3.

1.3.4. Let $\mathcal{A} \subseteq M$ be a finite set.

- (a) Prove that the semigroup $\mathbb{N}\mathcal{A}$ is saturated in M if and only if $\mathbb{N}\mathcal{A} = \text{Cone}(\mathcal{A}) \cap M$. Hint: Apply (1.2.2) to $\text{Cone}(\mathcal{A}) \subseteq M_{\mathbb{R}}$.
- (b) Complete the proof of (b) \Rightarrow (c) from Theorem 1.3.5.

1.3.5. Let N be a lattice.

- (a) Let $N_1 \subseteq N$ be a sublattice such that N/N_1 is torsion-free. Prove that there is a sublattice $N_2 \subseteq N$ such that $N = N_1 \oplus N_2$.
- (b) Let $u \in N$ be primitive as defined in the proof of Theorem 1.3.5. Prove that N has a basis e_1, \dots, e_n such that $e_1 = u$.

1.3.6. Prove Proposition 1.3.8.

1.3.7. Let p be a point of an irreducible affine variety V . Then p gives the maximal ideal $\mathfrak{m} = \{f \in \mathbb{C}[V] \mid f(p) = 0\}$ as well as the maximal ideal $\mathfrak{m}_{V,p} \subseteq \mathcal{O}_{V,p}$ defined in §1.0. Prove that the natural map $\mathfrak{m}/\mathfrak{m}^2 \rightarrow \mathfrak{m}_{V,p}/\mathfrak{m}_{V,p}^2$ is an isomorphism of \mathbb{C} -vector spaces.

1.3.8. Prove (1.3.3). Hint: Use Lemma 1.0.6 and Example 1.0.10.

1.3.9. Prove Proposition 1.3.15.

1.3.10. Prove the assertions made in the proof of Proposition 1.3.18 concerning the pairing $M'/M \times N/N' \rightarrow \mathbb{C}^*$ defined by $([m'], [u]) \mapsto e^{2\pi i \langle m', u \rangle}$.

1.3.11. Let $\mu_d = \{\zeta \in \mathbb{C}^* \mid \zeta^d = 1\}$ be the group of d th roots of unity. Then μ_d acts on \mathbb{C}^2 by $\zeta \cdot (x, y) = (\zeta x, \zeta y)$. Adapt Example 1.3.19 to show that $\mathbb{C}^2/\mu_d \simeq \widehat{C}_d$. Hint: Use lattices $N' = \mathbb{Z}^2 \subseteq N = \{(a/d, b/d) \mid a, b \in \mathbb{Z}, a + b \equiv 0 \pmod{d}\}$.

1.3.12. Prove that the normalization map in Proposition 1.3.8 is a toric morphism.

1.3.13. Let $\sigma_1 \subseteq (N_1)_{\mathbb{R}}$ and $\sigma_2 \subseteq (N_2)_{\mathbb{R}}$ be strongly convex rational polyhedral cones. This gives the cone $\sigma_1 \times \sigma_2 \subseteq (N_1 \oplus N_2)_{\mathbb{R}}$. Prove that $U_{\sigma_1 \times \sigma_2} \simeq U_{\sigma_1} \times U_{\sigma_2}$. Also explain how this result applies to (1.3.2).

1.3.14. By Proposition 1.3.1, a point p of an affine toric variety $V = \text{Spec}(\mathbb{C}[S])$ is represented by a semigroup homomorphism $\gamma : S \rightarrow \mathbb{C}$. Prove that p lies in the torus of V if and only if γ never vanishes, i.e., $\gamma(m) \neq 0$ for all $m \in S$.

Appendix: Tensor Products of Coordinate Rings

In this appendix, we will prove the following result used in §1.0 in our discussion of products of affine varieties.

Proposition 1.A.1. *If R and S are finitely generated \mathbb{C} -algebras without nilpotents, then the same is true for $R \otimes_{\mathbb{C}} S$.*

Proof. Since the tensor product is obviously a finitely generated \mathbb{C} -algebra, we need only prove that $R \otimes_{\mathbb{C}} S$ has no nilpotents. If we write $R \simeq \mathbb{C}[x_1, \dots, x_n]/I$, then I is radical and hence has a primary decomposition $I = \bigcap_{i=1}^s P_i$, where each P_i is prime ([35, Ch. 4, §7]). This gives

$$R \simeq \mathbb{C}[x_1, \dots, x_n]/I \longrightarrow \bigoplus_{i=1}^s \mathbb{C}[x_1, \dots, x_n]/P_i$$

where the map to the direct sum is injective. Each quotient $\mathbb{C}[x_1, \dots, x_n]/P_i$ is an integral domain and hence injects into its field of fractions K_i . This yields an injection

$$R \longrightarrow \bigoplus_{i=1}^s K_i,$$

and since tensoring over a field preserves exactness, we get an injection

$$R \otimes_{\mathbb{C}} S \hookrightarrow \bigoplus_{i=1}^s K_i \otimes_{\mathbb{C}} S.$$

Hence it suffices to prove that $K \otimes_{\mathbb{C}} S$ has no nilpotents when K is a finitely generated field extension of \mathbb{C} . A similar argument using S then reduces us to showing that $K \otimes_{\mathbb{C}} L$ has no nilpotents when K and L are finitely generated field extensions of \mathbb{C} .

Since \mathbb{C} has characteristic 0, the extension $\mathbb{C} \subseteq L$ has a separating transcendence basis ([97, p. 519]). This means that we can find $y_1, \dots, y_t \in L$ such that y_1, \dots, y_t are algebraically independent over \mathbb{C} and $F = \mathbb{C}(y_1, \dots, y_t) \subseteq L$ is a finite separable extension. Then

$$K \otimes_{\mathbb{C}} L \simeq K \otimes_{\mathbb{C}} (F \otimes_F L) \simeq (K \otimes_{\mathbb{C}} F) \otimes_F L.$$

But $C = K \otimes_{\mathbb{C}} F = K \otimes_{\mathbb{C}} \mathbb{C}(y_1, \dots, y_t) = K(y_1, \dots, y_t)$ is a field, so that we are reduced to considering

$$C \otimes_F L$$

where C and L are extensions of F and $F \subseteq L$ is finite and separable. The latter and the theorem of the primitive element imply that $L \simeq F[X]/\langle f(X) \rangle$, where $f(X)$ has distinct roots in some extension of F . Then

$$C \otimes_F L \simeq C \otimes_F F[X]/\langle f(X) \rangle \simeq C[X]/\langle f(X) \rangle.$$

Since $f(X)$ has distinct roots, this quotient ring has no nilpotents. Our result follows. \square

A final remark is that we can replace \mathbb{C} with any perfect field since finitely generated extensions of perfect fields have separating transcendence bases ([97, p. 519]).

Projective Toric Varieties

§2.0. Background: Projective Varieties

Our discussion assumes that the reader is familiar with the elementary theory of projective varieties, at the level of [35, Ch. 8].

In Chapter 1, we introduced affine toric varieties. In general, a toric variety is an irreducible variety X over \mathbb{C} containing a torus $T_N \simeq (\mathbb{C}^*)^n$ as a Zariski open set such that the action of $(\mathbb{C}^*)^n$ on itself extends to an action on X . We will learn in Chapter 3 that the concept of “variety” is somewhat subtle. Hence we will defer the formal definition of toric variety until then and instead concentrate on toric varieties that live in projective space \mathbb{P}^n , defined by

$$(2.0.1) \quad \mathbb{P}^n = (\mathbb{C}^{n+1} \setminus \{0\})/\mathbb{C}^*,$$

where \mathbb{C}^* acts via homotheties, i.e., $\lambda \cdot (a_0, \dots, a_n) = (\lambda a_0, \dots, \lambda a_n)$ for $\lambda \in \mathbb{C}^*$ and $(a_0, \dots, a_n) \in \mathbb{C}^{n+1}$. Thus (a_0, \dots, a_n) are *homogeneous coordinates* of a point in \mathbb{P}^n and are well-defined up to homothety.

The goal of this chapter is to use lattice points and polytopes to create toric varieties that lie in \mathbb{P}^n . We will use the affine semigroups and polyhedral cones introduced in Chapter 1 to describe the local structure of these varieties.

Homogeneous Coordinate Rings. A projective variety $V \subseteq \mathbb{P}^n$ is defined by the vanishing of finitely many homogeneous polynomials in the polynomial ring $S = \mathbb{C}[x_0, \dots, x_n]$. The *homogeneous coordinate ring* of V is the quotient ring

$$\mathbb{C}[V] = S/\mathbf{I}(V),$$

where $\mathbf{I}(V)$ is generated by all homogeneous polynomials that vanish on V .

The polynomial ring S is graded by setting $\deg(x_i) = 1$. This gives the decomposition $S = \bigoplus_{d=0}^{\infty} S_d$, where S_d is the vector space of homogeneous polynomials of degree d . Homogeneous ideals decompose similarly, and the above coordinate ring $\mathbb{C}[V]$ inherits a grading where

$$\mathbb{C}[V]_d = S_d / \mathbf{I}(V)_d.$$

The ideal $\mathbf{I}(V) \subseteq S = \mathbb{C}[x_0, \dots, x_n]$ also defines an affine variety $\widehat{V} \subseteq \mathbb{C}^{n+1}$, called the *affine cone* of V . The variety \widehat{V} satisfies

$$(2.0.2) \quad V = (\widehat{V} \setminus \{0\}) / \mathbb{C}^*,$$

and its coordinate ring is the homogeneous coordinate ring of V , i.e.,

$$\mathbb{C}[\widehat{V}] = \mathbb{C}[V].$$

Example 2.0.1. In Example 1.1.6 we encountered the ideal

$$I = \langle x_i x_{j+1} - x_{i+1} x_j \mid 0 \leq i < j \leq d-1 \rangle \subseteq \mathbb{C}[x_0, \dots, x_d]$$

generated by the 2×2 minors of the matrix

$$\begin{pmatrix} x_0 & x_1 & \cdots & x_{d-2} & x_{d-1} \\ x_1 & x_2 & \cdots & x_{d-1} & x_d \end{pmatrix}.$$

Since I is homogeneous, it defines a projective variety $C_d \subseteq \mathbb{P}^d$ that is the image of the map

$$\Phi : \mathbb{P}^1 \longrightarrow \mathbb{P}^d$$

defined in homogeneous coordinates by $(s, t) \mapsto (s^d, s^{d-1}t, \dots, st^{d-1}, t^d)$ (see Exercise 1.1.1). This shows that C_d is a curve, called the *rational normal curve* of degree d . Furthermore, the affine cone of C_d is the rational normal cone $\widehat{C}_d \subseteq \mathbb{C}^{d+1}$ discussed in Example 1.1.6.

We know from Chapter 1 that \widehat{C}_d is an affine toric surface; we will soon see that C_d is a projective toric curve. \diamond

Example 2.0.2. The affine toric variety $\mathbf{V}(xy - zw) \subseteq \mathbb{C}^4$ studied in Chapter 1 is the affine cone of the projective surface $V = \mathbf{V}(xy - zw) \subseteq \mathbb{P}^3$. Recall that this surface is isomorphic to $\mathbb{P}^1 \times \mathbb{P}^1$ via the Segre embedding

$$\mathbb{P}^1 \times \mathbb{P}^1 \longrightarrow \mathbb{P}^3$$

given by $(s, t; u, v) \mapsto (su, tv, sv, tu)$. We will see below that $V \simeq \mathbb{P}^1 \times \mathbb{P}^1$ is the projective toric variety coming from the unit square in the plane. \diamond

As in the affine case, a projective variety $V \subseteq \mathbb{P}^n$ has the *classical topology*, induced from the usual topology on \mathbb{P}^n , and the *Zariski topology*, where the Zariski closed sets are subvarieties of V (meaning projective varieties of \mathbb{P}^n contained in V) and the Zariski open sets are their complements.

Rational Functions on Irreducible Projective Varieties. A homogeneous polynomial $f \in S$ of degree d does not give a function on \mathbb{P}^n since

$$f(\lambda x_0, \dots, \lambda x_n) = \lambda^d f(x_0, \dots, x_n).$$

However, the quotient of two such polynomials $f, g \in S_d$ gives the well-defined function

$$\frac{f}{g} : \mathbb{P}^n \setminus \mathbf{V}(g) \rightarrow \mathbb{C}.$$

provided $g \neq 0$. We write this as $f/g : \mathbb{P}^n \dashrightarrow \mathbb{C}$ and say that f/g is a *rational function* on \mathbb{P}^n .

More generally, suppose that $V \subseteq \mathbb{P}^n$ is irreducible, and let $f, g \in \mathbb{C}[V] = \mathbb{C}[\widehat{V}]$ be homogeneous of the same degree with $g \neq 0$. Then f and g give functions on the affine cone \widehat{V} and hence an element $f/g \in \mathbb{C}(\widehat{V})$. By (2.0.2), this induces a rational function $f/g : V \dashrightarrow \mathbb{C}$. Thus

$$\mathbb{C}(V) = \{f/g \in \mathbb{C}(\widehat{V}) \mid f, g \in \mathbb{C}[V] \text{ homogeneous of the same degree, } g \neq 0\}$$

is the field of rational functions on V . It is customary to write the set on the left as $\mathbb{C}(\widehat{V})_0$ since it consists of the degree 0 elements of $\mathbb{C}(\widehat{V})$.

Affine Pieces of Projective Varieties. A projective variety $V \subseteq \mathbb{P}^n$ is a union of Zariski open sets that are affine. To see why, let $U_i = \mathbb{P}^n \setminus \mathbf{V}(x_i)$. Then $U_i \simeq \mathbb{C}^n$ via the map

$$(2.0.3) \quad (a_0, \dots, a_n) \mapsto \left(\frac{a_0}{a_i}, \dots, \frac{a_{i-1}}{a_i}, \frac{a_{i+1}}{a_i}, \dots, \frac{a_n}{a_i} \right),$$

so that in the notation of Chapter 1, we have

$$U_i = \text{Spec} \left(\mathbb{C} \left[\frac{x_0}{x_i}, \dots, \frac{x_{i-1}}{x_i}, \frac{x_{i+1}}{x_i}, \dots, \frac{x_n}{x_i} \right] \right).$$

Then $V \cap U_i$ is a Zariski open subset of V that maps via (2.0.3) to the affine variety in \mathbb{C}^n defined by the equations

$$(2.0.4) \quad f \left(\frac{x_0}{x_i}, \dots, \frac{x_{i-1}}{x_i}, 1, \frac{x_{i+1}}{x_i}, \dots, \frac{x_n}{x_i} \right) = 0$$

as f varies over all homogeneous polynomials in $\mathbf{I}(V)$.

We call $V \cap U_i$ an *affine piece* of V . These affine pieces cover V since the U_i cover \mathbb{P}^n . Using localization, we can describe the coordinate rings of the affine pieces as follows. The variable x_i induces an element $\bar{x}_i \in \mathbb{C}[V]$, so that we get the localization

$$(2.0.5) \quad \mathbb{C}[V]_{\bar{x}_i} = \{f/\bar{x}_i^k \mid f \in \mathbb{C}[V], k \geq 0\}$$

as in Exercises 1.0.2 and 1.0.3. Note that $\mathbb{C}[V]_{\bar{x}_i}$ has a well-defined \mathbb{Z} -grading given by $\deg(f/\bar{x}_i^k) = \deg(f) - k$ when f is homogeneous. Then

$$(2.0.6) \quad (\mathbb{C}[V]_{\bar{x}_i})_0 = \{f/\bar{x}_i^k \in \mathbb{C}[V]_{\bar{x}_i} \mid f \text{ is homogeneous of degree } k\}$$

is the subring of $\mathbb{C}[V]_{\bar{x}_i}$ consisting of all elements of degree 0. This gives an affine piece of V as follows.

Lemma 2.0.3. *The affine piece $V \cap U_i$ of V has coordinate ring*

$$\mathbb{C}[V \cap U_i] \simeq (\mathbb{C}[V]_{\bar{x}_i})_0.$$

Proof. We have an exact sequence

$$0 \longrightarrow \mathbf{I}(V) \longrightarrow \mathbb{C}[x_0, \dots, x_n] \longrightarrow \mathbb{C}[V] \longrightarrow 0.$$

If we localize at x_i , we get the exact sequence

$$(2.0.7) \quad 0 \longrightarrow \mathbf{I}(V)_{x_i} \longrightarrow \mathbb{C}[x_0, \dots, x_n]_{x_i} \longrightarrow \mathbb{C}[V]_{\bar{x}_i} \longrightarrow 0$$

since localization preserves exactness (Exercises 2.0.1 and 2.0.2). These sequences preserve degrees, so that taking elements of degree 0 gives the exact sequence

$$0 \longrightarrow (\mathbf{I}(V)_{x_i})_0 \longrightarrow (\mathbb{C}[x_0, \dots, x_n]_{x_i})_0 \longrightarrow (\mathbb{C}[V]_{\bar{x}_i})_0 \longrightarrow 0.$$

Note that $(\mathbb{C}[x_0, \dots, x_n]_{x_i})_0 = \mathbb{C}\left[\frac{x_0}{x_i}, \dots, \frac{x_{i-1}}{x_i}, \frac{x_{i+1}}{x_i}, \dots, \frac{x_n}{x_i}\right]$. If $f \in \mathbf{I}(V)$ is homogeneous of degree k , then

$$f/x_i^k = f\left(\frac{x_0}{x_i}, \dots, \frac{x_{i-1}}{x_i}, 1, \frac{x_{i+1}}{x_i}, \dots, \frac{x_n}{x_i}\right) \in (\mathbf{I}(V)_{x_i})_0.$$

By (2.0.4), we conclude that $(\mathbf{I}(V)_{x_i})_0$ maps to $\mathbf{I}(V \cap U_i)$. To show that this map is onto, let $g\left(\frac{x_0}{x_i}, \dots, \frac{x_{i-1}}{x_i}, \frac{x_{i+1}}{x_i}, \dots, \frac{x_n}{x_i}\right) \in \mathbf{I}(V \cap U_i)$. For $k \gg 0$, $x_i^k g = f(x_0, \dots, x_n)$ is homogeneous of degree k . It then follows easily that $x_i f$ vanishes on V since $g = 0$ on $V \cap U_i$ and $x_i = 0$ on the complement of U_i . Thus $x_i f \in \mathbf{I}(V)$, and then $(x_i f)/(x_i^{k+1}) \in (\mathbf{I}(V)_{x_i})_0$ maps to g . The lemma follows immediately. \square

One can also explore what happens when we intersect affine pieces $V \cap U_i$ and $V \cap U_j$ for $i \neq j$. By Exercise 2.0.3, $V \cap U_i \cap U_j$ is affine with coordinate ring

$$(2.0.8) \quad \mathbb{C}[V \cap U_i \cap U_j] \simeq (\mathbb{C}[V]_{\bar{x}_i \bar{x}_j})_0.$$

We will apply this to projective toric varieties in §2.2. We will also see later in the book that Lemma 2.0.3 is related to the “Proj” construction, where Proj of a graded ring gives a projective variety, just as Spec of an ordinary ring gives an affine variety.

Products of Projective Spaces. One can study the product $\mathbb{P}^n \times \mathbb{P}^m$ of projective spaces using the bigraded ring $\mathbb{C}[x_0, \dots, x_n, y_0, \dots, y_m]$, where x_i has bidegree $(1, 0)$ and y_i has bidegree $(0, 1)$. Then a bihomogeneous polynomial f of bidegree (a, b) gives a well-defined equation $f = 0$ in $\mathbb{P}^n \times \mathbb{P}^m$. This allows us to define varieties in $\mathbb{P}^n \times \mathbb{P}^m$ using bihomogeneous ideals. In particular, the ideal $\mathbf{I}(V)$ of a variety $V \subseteq \mathbb{P}^n \times \mathbb{P}^m$ is a bihomogeneous ideal.

Another way to study $\mathbb{P}^n \times \mathbb{P}^m$ is via the *Segre embedding*

$$\mathbb{P}^n \times \mathbb{P}^m \longrightarrow \mathbb{P}^{nm+n+m}$$

defined by mapping $(a_0, \dots, a_n, b_0, \dots, b_m)$ to the point

$$(a_0 b_0, a_0 b_1, \dots, a_0 b_m, a_1 b_0, \dots, a_1 b_m, \dots, a_n b_0, \dots, a_n b_m).$$

This map is studied in [35, Ex. 14 of Ch. 8, §4]. If \mathbb{P}^{nm+n+m} has homogeneous coordinates x_{ij} for $0 \leq i \leq n, 0 \leq j \leq m$, then $\mathbb{P}^n \times \mathbb{P}^m \subseteq \mathbb{P}^{nm+n+m}$ is defined by the vanishing of the 2×2 minors of the $(n+1) \times (m+1)$ matrix

$$\begin{pmatrix} x_{00} & \cdots & x_{0m} \\ \vdots & & \vdots \\ x_{n0} & \cdots & x_{nm} \end{pmatrix}.$$

This follows since an $(n+1) \times (m+1)$ matrix has rank 1 if and only if it is a product $A^t B$, where A and B are nonzero row matrices of lengths $n+1$ and $m+1$.

These approaches give the same notion of what it means to be a subvariety of $\mathbb{P}^n \times \mathbb{P}^m$. A homogeneous polynomial $F(x_{ij})$ of degree d gives the bihomogeneous polynomial $F(x_i y_j)$ of bidegree (d, d) . Hence any subvariety of \mathbb{P}^{nm+n+m} lying in $\mathbb{P}^n \times \mathbb{P}^m$ can be defined by a bihomogeneous ideal in $\mathbb{C}[x_0, \dots, x_n, y_0, \dots, y_m]$. Going the other way takes more thought and is discussed in Exercise 2.0.5.

We also have the following useful result proved in Exercise 2.0.6.

Proposition 2.0.4. *Given subvarieties $V \subseteq \mathbb{P}^n$ and $W \subseteq \mathbb{P}^m$, the product $V \times W$ is a subvariety of $\mathbb{P}^n \times \mathbb{P}^m$. \square*

Weighted Projective Space. The graded ring associated to projective space \mathbb{P}^n is $\mathbb{C}[x_0, \dots, x_n]$, where each variable x_i has degree 1. More generally, let q_0, \dots, q_n be positive integers with $\gcd(q_0, \dots, q_n) = 1$ and define

$$\mathbb{P}(q_0, \dots, q_n) = (\mathbb{C}^{n+1} \setminus \{0\}) / \sim,$$

where \sim is the equivalence relation

$$(a_0, \dots, a_n) \sim (b_0, \dots, b_n) \iff a_i = \lambda^{q_i} b_i, \quad i = 0, \dots, n \text{ for some } \lambda \in \mathbb{C}^*.$$

We call $\mathbb{P}(q_0, \dots, q_n)$ a *weighted projective space*. Note that $\mathbb{P}^n = \mathbb{P}(1, \dots, 1)$.

The ring corresponding to $\mathbb{P}(q_0, \dots, q_n)$ is the graded ring $\mathbb{C}[x_0, \dots, x_n]$, where x_i now has degree q_i . A polynomial f is *weighted homogeneous* of degree d if every monomial x^α appearing in f satisfies $\alpha \cdot (q_0, \dots, q_n) = d$. The $f = 0$ is well-defined on $\mathbb{P}(q_0, \dots, q_n)$ when f is weighted homogeneous, so that one can define varieties in $\mathbb{P}(q_0, \dots, q_n)$ using weighted homogeneous ideals of $\mathbb{C}[x_0, \dots, x_n]$.

Example 2.0.5. We can embed the weighted projective plane $\mathbb{P}(1, 1, 2)$ in \mathbb{P}^3 using the monomials $x_0^2, x_0 x_1, x_1^2, x_2$ of weighted degree 2. In other words, the map

$$\mathbb{P}(1, 1, 2) \longrightarrow \mathbb{P}^3$$

given by

$$(a_0, a_1, a_2) \longmapsto (a_0^2, a_0 a_1, a_1^2, a_2)$$

is well-defined and injective. One can check that this map induces

$$\mathbb{P}(1, 1, 2) \simeq \mathbf{V}(y_0 y_2 - y_1^2) \subseteq \mathbb{P}^3,$$

where y_0, y_1, y_2, y_3 are homogeneous coordinates on \mathbb{P}^3 . \diamond

Later in the book we will use toric methods to construct projective embeddings of arbitrary weighted projective spaces.

Exercises for §2.0.

2.0.1. Let R be a commutative \mathbb{C} -algebra. Given $f \in R \setminus \{0\}$ and an exact sequence of R -modules $0 \rightarrow M_1 \rightarrow M_2 \rightarrow M_3 \rightarrow 0$, prove that

$$0 \longrightarrow M_1 \otimes_R R_f \longrightarrow M_2 \otimes_R R_f \longrightarrow M_3 \otimes_R R_f \longrightarrow 0$$

is also exact, where R_f is the localization of R at f defined in Exercises 1.0.2 and 1.0.3.

2.0.2. Let $V \subseteq \mathbb{P}^n$ be a projective variety. If we set $S = \mathbb{C}[x_0, \dots, x_n]$, then V has coordinate ring $\mathbb{C}[V] = S/\mathbf{I}(V)$. Let \bar{x}_i be the image of x_i in $\mathbb{C}[V]$.

- (a) Note that $\mathbb{C}[V]$ is an S -module. Prove that $\mathbb{C}[V]_{\bar{x}_i} \simeq \mathbb{C}[V] \otimes_S S_{x_i}$.
- (b) Use part (a) and the previous exercise to prove that (2.0.7) is exact.

2.0.3. Prove the claim made in (2.0.8).

2.0.4. Let $V \subseteq \mathbb{P}^n$ be a projective variety. Take $f_0, \dots, f_m \in S_d$ such that the intersection $V \cap \mathbf{V}(f_0, \dots, f_m)$ is empty. Prove that the map

$$(a_0, \dots, a_n) \longmapsto (f_0(a_0, \dots, a_n), \dots, f_m(a_0, \dots, a_n))$$

induces a well-defined function $\Phi : V \rightarrow \mathbb{P}^m$.

2.0.5. Let $V \subseteq \mathbb{P}^n \times \mathbb{P}^m$ be defined by $f_\ell(x_i, y_j) = 0$, where $f_\ell(x_i, y_j)$ is bihomogenous of bidegree (a_ℓ, b_ℓ) , $\ell = 1, \dots, s$. The goal of this exercise is to show that when we embed $\mathbb{P}^n \times \mathbb{P}^m$ in \mathbb{P}^{nm+n+m} via the Segre embedding described in the text, V becomes a subvariety of \mathbb{P}^{nm+n+m} .

- (a) For each ℓ , pick an integer $d_\ell \geq \max\{a_\ell, b_\ell\}$ and consider the polynomials $f_{\ell, \alpha, \beta} = x^\alpha y^\beta f_\ell(x_i, y_j)$ where $\ell = 0, \dots, s$ and $|\alpha| = d_\ell - a_\ell$, $|\beta| = d_\ell - b_\ell$. Note that $f_{\ell, \alpha, \beta}$ is bihomogenous of bidegree (d_ℓ, d_ℓ) . Prove that $V \subseteq \mathbb{P}^n \times \mathbb{P}^m$ is defined by the vanishing of the $f_{\ell, \alpha, \beta}$.
- (b) Use part (a) to show that V is a subvariety of \mathbb{P}^{nm+n+m} under the Segre embedding.

2.0.6. Prove Proposition 2.0.4

2.0.7. Consider the Segre embedding $\mathbb{P}^1 \times \mathbb{P}^1 \rightarrow \mathbb{P}^3$. Show that after relabeling coordinates, the affine cone of $\mathbb{P}^1 \times \mathbb{P}^1$ in \mathbb{P}^3 is the variety $\mathbf{V}(xy - zw) \subseteq \mathbb{C}^4$ featured in many examples in Chapter 1.

§2.1. Lattice Points and Projective Toric Varieties

We first observe that \mathbb{P}^n is a toric variety with torus

$$\begin{aligned} T_{\mathbb{P}^n} &= \mathbb{P}^n \setminus \mathbf{V}(x_0 \cdots x_n) = \{(a_0, \dots, a_n) \in \mathbb{P}^n \mid a_0 \cdots a_n \neq 0\} \\ &= \{(1, t_1, \dots, t_n) \in \mathbb{P}^n \mid t_1, \dots, t_n \in \mathbb{C}^*\} \simeq (\mathbb{C}^*)^n. \end{aligned}$$

The action of $T_{\mathbb{P}^n}$ on itself clearly extends to an action on \mathbb{P}^n , making \mathbb{P}^n a toric variety. To describe the lattices associated to $T_{\mathbb{P}^n}$, we use the exact sequence of tori

$$1 \longrightarrow \mathbb{C}^* \longrightarrow (\mathbb{C}^*)^{n+1} \xrightarrow{\pi} T_{\mathbb{P}^n} \longrightarrow 1$$

coming from the definition (2.0.1) of \mathbb{P}^n . Hence the character lattice of $T_{\mathbb{P}^n}$ is

$$(2.1.1) \quad \mathcal{M}_n = \{(a_0, \dots, a_n) \in \mathbb{Z}^{n+1} \mid \sum_{i=0}^n a_i = 0\},$$

and the lattice of one-parameter subgroups \mathcal{N}_n is the quotient

$$\mathcal{N}_n = \mathbb{Z}^{n+1} / \mathbb{Z}(1, \dots, 1).$$

Lattice Points and Projective Toric Varieties. Let T_N be a torus with lattices M and N as usual. In Chapter 1, we used a finite set of lattice points of $\mathcal{A} = \{m_1, \dots, m_s\} \subseteq M$ to create the affine toric variety $Y_{\mathcal{A}}$ as the Zariski closure of the image of the map

$$\Phi_{\mathcal{A}} : T_N \longrightarrow \mathbb{C}^s, \quad t \longmapsto (\chi^{m_1}(t), \dots, \chi^{m_s}(t)).$$

To get a projective toric variety, we regard $\Phi_{\mathcal{A}}$ as a map to $(\mathbb{C}^*)^s$ and compose with the homomorphism $\pi : (\mathbb{C}^*)^s \rightarrow T_{\mathbb{P}^{s-1}}$ to obtain

$$(2.1.2) \quad T_N \xrightarrow{\Phi_{\mathcal{A}}} \mathbb{C}^s \xrightarrow{\pi} T_{\mathbb{P}^{s-1}} \subseteq \mathbb{P}^{s-1}.$$

Definition 2.1.1. Given a finite set $\mathcal{A} \subseteq M$, the **projective toric variety** $X_{\mathcal{A}}$ is the Zariski closure in \mathbb{P}^{s-1} of the image of the map $\pi \circ \Phi_{\mathcal{A}}$ from (2.1.2).

Proposition 2.1.2. $X_{\mathcal{A}}$ is a toric variety of dimension equal to the dimension of the smallest affine subspace of $M_{\mathbb{R}}$ containing \mathcal{A} .

Proof. The proof that $X_{\mathcal{A}} \subseteq \mathbb{P}^{s-1}$ is a toric variety is similar to the proof given in Propostion 1.1.8 of Chapter 1 that $Y_{\mathcal{A}} \subseteq \mathbb{C}^s$ is a toric variety. The assertion concerning the dimension of $X_{\mathcal{A}}$ will follow from Proposition 2.1.6 below. \square

More concretely, $X_{\mathcal{A}}$ is the Zariski closure of the image of the map

$$T_N \longrightarrow \mathbb{P}^{s-1}, \quad t \longmapsto (\chi^{m_1}(t), \dots, \chi^{m_s}(t))$$

given by the characters coming from $\mathcal{A} = \{m_1, \dots, m_s\} \subseteq M$. In particular, if $M = \mathbb{Z}^n$, then χ^{m_i} is the Laurent monomial t^{m_i} and $X_{\mathcal{A}}$ is the Zariski closure of the image of

$$T_N \longrightarrow \mathbb{P}^{s-1}, \quad t \longmapsto (t^{m_1}, \dots, t^{m_s}).$$

In the literature, $\mathcal{A} \subseteq \mathbb{Z}^n$ is often given as an $n \times s$ matrix A with integer entries, so that the elements of \mathcal{A} are the columns of A .

Here is an example where the lattice points themselves are matrices.

Example 2.1.3. Let $M = \mathbb{Z}^{3 \times 3}$ be the lattice of 3×3 integer matrices and let

$$\mathcal{P}_3 = \{3 \times 3 \text{ permutation matrices}\} \subseteq \mathbb{Z}^{3 \times 3}.$$

Write $\mathbb{C}[M] = \mathbb{C}[t_1^{\pm 1}, \dots, t_9^{\pm 1}]$, where the variables give the generic 3×3 matrix

$$\begin{pmatrix} t_1 & t_2 & t_3 \\ t_4 & t_5 & t_6 \\ t_7 & t_8 & t_9 \end{pmatrix}$$

with nonzero entries. Also let \mathbb{P}^5 have homogeneous coordinates x_{ijk} indexed by triples such that $\begin{pmatrix} 1 & 2 & 3 \\ i & j & k \end{pmatrix}$ is a permutation in S_3 . Then $X_{\mathcal{P}_3} \subseteq \mathbb{P}^5$ is the Zariski closure of the image of the map $T_N \rightarrow \mathbb{P}^5$ given by the Laurent monomials $t_i t_j t_k$ for $\begin{pmatrix} 1 & 2 & 3 \\ i & j & k \end{pmatrix} \in S_3$. The ideal of $X_{\mathcal{P}_3}$ is

$$\mathbf{I}(X_{\mathcal{P}_3}) = \langle x_{123}x_{231}x_{312} - x_{132}x_{321}x_{213} \rangle \subseteq \mathbb{C}[x_{ijk}],$$

where the relation comes from the fact that the sum of the permutation matrices corresponding to $x_{123}, x_{231}, x_{312}$ equals the sum of the other three (Exercise 2.1.1). Ideals of the toric varieties arising from permutation matrices have applications to sampling problems in statistics [166, p. 148]. \diamond

The Affine Cone of a Projective Toric Variety. The projective variety $X_{\mathcal{A}} \subseteq \mathbb{P}^{s-1}$ has an affine cone $\widehat{X}_{\mathcal{A}} \subseteq \mathbb{C}^s$. How does $\widehat{X}_{\mathcal{A}}$ relate to the affine toric variety $Y_{\mathcal{A}} \subseteq \mathbb{C}^s$ constructed in Chapter 1?

Recall from Chapter 1 that when $\mathcal{A} = \{m_1, \dots, m_s\} \subseteq M$, the map $e_i \mapsto m_i$ induces an exact sequence

$$(2.1.3) \quad 0 \longrightarrow L \longrightarrow \mathbb{Z}^s \longrightarrow M$$

and that the ideal of $Y_{\mathcal{A}}$ is the toric ideal

$$I_L = \langle x^\alpha - x^\beta \mid \alpha, \beta \in \mathbb{N}^s \text{ and } \alpha - \beta \in L \rangle$$

(Proposition 1.1.9). Then we have the following result.

Proposition 2.1.4. *Given $Y_{\mathcal{A}}$, $X_{\mathcal{A}}$ and I_L as above, the following are equivalent:*

- (a) $Y_{\mathcal{A}} \subseteq \mathbb{C}^s$ is the affine cone $\widehat{X}_{\mathcal{A}}$ of $X_{\mathcal{A}} \subseteq \mathbb{P}^{s-1}$.
- (b) $I_L = \mathbf{I}(X_{\mathcal{A}})$.
- (c) I_L is homogeneous.
- (d) There is $u \in N$ and $k > 0$ in \mathbb{N} such that $\langle m_i, u \rangle = k$ for $i = 1, \dots, s$.

Proof. The equivalence (a) \Leftrightarrow (b) follows from the equalities $\mathbf{I}(X_{\mathcal{A}}) = \mathbf{I}(\widehat{X}_{\mathcal{A}})$ and $I_L = \mathbf{I}(Y_{\mathcal{A}})$, and the implication (b) \Rightarrow (c) is obvious.

For (c) \Rightarrow (d), assume that I_L is a homogeneous ideal and take $x^\alpha - x^\beta \in I_L$ for $\alpha - \beta \in L$. If x^α and x^β had different degrees, then $x^\alpha, x^\beta \in I_L = \mathbf{I}(Y_{\mathcal{A}})$ would vanish on $Y_{\mathcal{A}}$. This is impossible since $(1, \dots, 1) \in Y_{\mathcal{A}}$ by (2.1.2). Hence x^α and x^β have the same degree, which implies that $\ell \cdot (1, \dots, 1) = 0$ for all $\ell \in L$. Now tensor (2.1.3) with \mathbb{Q} and take duals to obtain an exact sequence

$$N_{\mathbb{Q}} \longrightarrow \mathbb{Q}^s \longrightarrow \text{Hom}_{\mathbb{Q}}(L_{\mathbb{Q}}, \mathbb{Q}) \longrightarrow 0.$$

The above argument shows that $(1, \dots, 1) \in \mathbb{Q}^s$ maps to zero in $\text{Hom}_{\mathbb{Q}}(L_{\mathbb{Q}}, \mathbb{Q})$ and hence comes from an element $\tilde{u} \in N_{\mathbb{Q}}$. In other words, $\langle m_i, \tilde{u} \rangle = 1$ for all i . Clearing denominators gives the desired $u \in N$ and $k > 0$ in \mathbb{N} .

Finally, we prove (d) \Rightarrow (b). Since $I_L = \mathbf{I}(Y_{\mathcal{A}})$, it suffices to show that

$$\widehat{X}_{\mathcal{A}} \cap (\mathbb{C}^*)^s \subseteq Y_{\mathcal{A}}.$$

Let $p \in \widehat{X}_{\mathcal{A}} \cap (\mathbb{C}^*)^s$. Since $X_{\mathcal{A}} \cap T_{\mathbb{P}^{s-1}}$ is the torus of $X_{\mathcal{A}}$, it follows that

$$p = \mu \cdot (\chi^{m_1}(t), \dots, \chi^{m_s}(t))$$

for some $\mu \in \mathbb{C}^*$ and $t \in T_N$. The element $u \in N$ from part (d) gives a one-parameter subgroup of T_N , which we write as $\tau \mapsto \lambda^u(\tau)$ for $\tau \in \mathbb{C}^*$. Then $\lambda^u(\tau)t \in T_N$ maps to the point $q \in Y_{\mathcal{A}}$ given by

$$q = (\chi^{m_1}(\lambda^u(\tau)t), \dots, \chi^{m_s}(\lambda^u(\tau)t)) = (\tau^{\langle m_1, u \rangle} \chi^{m_1}(t), \dots, \tau^{\langle m_s, u \rangle} \chi^{m_s}(t)),$$

since $\chi^m(\lambda^u(\tau)) = \tau^{\langle m, u \rangle}$ by the description of $\langle \cdot, \cdot \rangle$ given in §1.1. The hypothesis of part (d) allows us to rewrite q as

$$q = \tau^k \cdot (\chi^{m_1}(t), \dots, \chi^{m_s}(t)).$$

Using $k > 0$, we can choose τ so that $p = q \in Y_{\mathcal{A}}$. This completes the proof. \square

The condition $\langle m_i, u \rangle = k$, $i = 1, \dots, s$, for some $u \in N$ and $k > 0$ in \mathbb{N} means that \mathcal{A} lies in an affine hyperplane of $M_{\mathbb{Q}}$ not containing the origin. When $M = \mathbb{Z}^n$ and \mathcal{A} consists of the columns of an $n \times s$ integer matrix A , this is equivalent to $(1, \dots, 1)$ lying in the row space of A (Exercise 2.1.2).

Example 2.1.5. We will examine the rational normal curve $C_d \subseteq \mathbb{P}^d$ using two different sets of lattice points.

First let \mathcal{A} consist of the columns of the $2 \times (d+1)$ matrix

$$A = \begin{pmatrix} d & d-1 & \cdots & 1 & 0 \\ 0 & 1 & \cdots & d-1 & d \end{pmatrix}.$$

The columns give the Laurent monomials defining the rational normal curve C_d in Example 2.0.1. It follows that C_d is a projective toric variety. The ideal of C_d is the homogeneous ideal given in Example 2.0.1, and the corresponding affine hyperplane of \mathbb{Z}^2 containing \mathcal{A} (= the columns of A) consists of all points (a, b) satisfying $a + b = d$. It is equally easy to see that $(1, \dots, 1)$ is in the row space of A . In particular, we have

$$X_{\mathcal{A}} = C_d \quad \text{and} \quad Y_{\mathcal{A}} = \widehat{C}_d.$$

Now let $\mathcal{B} = \{0, 1, \dots, d-1, d\} \subseteq \mathbb{Z}$. This gives the map

$$\Phi_{\mathcal{B}} : \mathbb{C}^* \longrightarrow \mathbb{P}^d, \quad t \mapsto (1, t, \dots, t^{d-1}, t^d).$$

The resulting projective variety is the rational normal curve, i.e., $X_{\mathcal{B}} = C_d$, but the affine variety of \mathcal{B} is *not* the rational normal cone, i.e., $Y_{\mathcal{B}} \neq \widehat{C}_d$. This is because $\mathbf{I}(Y_{\mathcal{B}}) \subseteq \mathbb{C}[x_0, \dots, x_d]$ is not homogeneous. For example, $x_1^2 - x_2$ vanishes at $(1, t, \dots, t^{d-1}, t^d) \in \mathbb{C}^{d+1}$ for all $t \in \mathbb{C}^*$. Thus $x_1^2 - x_2 \in \mathbf{I}(Y_{\mathcal{B}})$. \diamond

Given any $\mathcal{A} \subseteq M$, there is a standard way to modify \mathcal{A} so that the conditions of Proposition 2.1.4 are met: use $\mathcal{A} \times \{1\} \subseteq M \oplus \mathbb{Z}$. This lattice corresponds to the torus $T_n \times \mathbb{C}^*$, and since

$$(2.1.4) \quad \Phi_{\mathcal{A} \times \{1\}}(t, \mu) = (\chi^{m_1}(t)\mu, \dots, \chi^{m_s}(t)\mu) = \mu \cdot (\chi^{m_1}(t), \dots, \chi^{m_s}(t)),$$

it follows immediately that $X_{\mathcal{A} \times \{1\}} = X_{\mathcal{A}} \subseteq \mathbb{P}^{s-1}$. Since $\mathcal{A} \times \{1\}$ lies in an affine hyperplane missing the origin, Proposition 2.1.4 implies that $X_{\mathcal{A}}$ has affine cone $Y_{\mathcal{A} \times \{1\}} = \widehat{X}_{\mathcal{A}}$. When $M = \mathbb{Z}^n$ and \mathcal{A} is represented by the columns of an $n \times s$ integer matrix A , we obtain $\mathcal{A} \times \{1\}$ by adding the row $(1, \dots, 1)$ to A .

The Torus of a Projective Toric Variety. Our next task is to determine the torus of $X_{\mathcal{A}}$. We will do so by identifying its character lattice. This will also tell us the dimension of $X_{\mathcal{A}}$. Given $\mathcal{A} = \{m_1, \dots, m_s\} \subseteq M$, we set

$$\mathbb{Z}'\mathcal{A} = \left\{ \sum_{i=1}^s a_i m_i \mid a_i \in \mathbb{Z}, \sum_{i=1}^s a_i = 0 \right\}.$$

The rank of $\mathbb{Z}'\mathcal{A}$ is the dimension of the smallest affine subspace of $M_{\mathbb{R}}$ containing the set \mathcal{A} (Exercise 2.1.3).

Proposition 2.1.6. *Let $X_{\mathcal{A}}$ be the projective toric variety of $\mathcal{A} \subseteq M$. Then:*

- (a) *The lattice $\mathbb{Z}'\mathcal{A}$ is the character lattice of the torus of $X_{\mathcal{A}}$.*
- (b) *The dimension of $X_{\mathcal{A}}$ is the dimension of the smallest affine subspace of $M_{\mathbb{R}}$ containing \mathcal{A} . In particular,*

$$\dim X_{\mathcal{A}} = \begin{cases} \text{rank } \mathbb{Z}'\mathcal{A} - 1 & \text{if } \mathcal{A} \text{ satisfies the conditions of Proposition 2.1.4} \\ \text{rank } \mathbb{Z}'\mathcal{A} & \text{otherwise.} \end{cases}$$

Proof. To prove part (a), let M' be the character lattice of the torus $T_{X_{\mathcal{A}}}$ of $X_{\mathcal{A}}$. By (2.1.2), we have the commutative diagram

$$\begin{array}{ccccc} T_N & \longrightarrow & T_{\mathbb{P}^{s-1}} & \hookrightarrow & \mathbb{P}^{s-1} \\ & \searrow & \uparrow & & \\ & & T_{X_{\mathcal{A}}} & & \end{array}$$

which induces the commutative diagram of character lattices

$$\begin{array}{ccc} M & \longleftarrow & \mathcal{M}_{s-1} \\ & \swarrow & \downarrow \\ & & M' \end{array}$$

since $\mathcal{M}_{s-1} = \{(a_1, \dots, a_s) \in \mathbb{Z}^s \mid \sum_{i=0}^s a_i m_i = 0\}$ is the character lattice of $T_{\mathbb{P}^{s-1}}$ by (2.1.1). The map $\mathcal{M}_{s-1} \rightarrow M$ is induced by the map $\mathbb{Z}^s \rightarrow M$ that sends e_i to m_i . Thus $\mathbb{Z}'\mathcal{A}$ is the image of $\mathcal{M}_{s-1} \rightarrow M$ and hence equals M' by the above diagram.

The first assertion of part (b) follows from part (a) and the observation that $\text{rank } \mathbb{Z}'\mathcal{A}$ is the dimension of the smallest affine subspace of $M_{\mathbb{R}}$ containing \mathcal{A} .

Furthermore, if $Y_{\mathcal{A}}$ equals the affine cone of $X_{\mathcal{A}}$, then there is $u \in N$ with $\langle m_i, u \rangle = k > 0$ for all i by Proposition 2.1.4. This implies that $\langle \sum_{i=1}^s a_i m_i, u \rangle = k(\sum_{i=1}^s a_i)$, which gives the exact sequence

$$0 \longrightarrow \mathbb{Z}'_{\mathcal{A}} \longrightarrow \mathbb{Z}_{\mathcal{A}} \xrightarrow{\langle \cdot, u \rangle} k\mathbb{Z} \longrightarrow 0.$$

Then $k > 0$ implies $\text{rank } \mathbb{Z}_{\mathcal{A}} - 1 = \text{rank } \mathbb{Z}'_{\mathcal{A}} = \dim X_{\mathcal{A}}$. However, if $Y_{\mathcal{A}} \neq \widehat{X}_{\mathcal{A}}$, then the ideal I_L is not homogeneous. Thus some generator $x^\alpha - y^\beta$ is not homogeneous, so that $(\alpha - \beta) \cdot (1, \dots, 1) \neq 0$. But $\alpha - \beta \in L$, where L is defined by

$$0 \longrightarrow L \longrightarrow \mathbb{Z}^s \longrightarrow \mathbb{Z}_{\mathcal{A}} \longrightarrow 0.$$

This implies that in the exact sequence

$$0 \longrightarrow \mathcal{M}_{s-1} \longrightarrow \mathbb{Z}^s \longrightarrow \mathbb{Z} \longrightarrow 0$$

(see (2.1.1)), the image of $L \subseteq \mathbb{Z}^s$ is $\ell\mathbb{Z} \subseteq \mathbb{Z}$ for some $\ell > 0$. This gives a diagram

$$\begin{array}{ccccccc} & & 0 & & 0 & & 0 \\ & & \downarrow & & \downarrow & & \downarrow \\ 0 & \rightarrow & L \cap \mathcal{M}_{s-1} & \rightarrow & L & \rightarrow & \ell\mathbb{Z} \rightarrow 0 \\ & & \downarrow & & \downarrow & & \downarrow \\ 0 & \rightarrow & \mathcal{M}_{s-1} & \rightarrow & \mathbb{Z}^s & \rightarrow & \mathbb{Z} \rightarrow 0 \\ & & \downarrow & & \downarrow & & \downarrow \\ 0 & \rightarrow & \mathbb{Z}'_{\mathcal{A}} & \rightarrow & \mathbb{Z}_{\mathcal{A}} & \rightarrow & \mathbb{Z}/\ell\mathbb{Z} \rightarrow 0 \\ & & \downarrow & & \downarrow & & \downarrow \\ & & 0 & & 0 & & 0 \end{array}$$

with exact rows and columns. Hence $\text{rank } \mathbb{Z}_{\mathcal{A}} = \text{rank } \mathbb{Z}'_{\mathcal{A}} = \dim X_{\mathcal{A}}$. □

Example 2.1.7. Let $\mathcal{A} = \{e_1, e_2, e_1 + 2e_2, 2e_1 + e_2\} \subseteq \mathbb{Z}^2$. One computes that $\mathbb{Z}_{\mathcal{A}} = \mathbb{Z}^2$ but $\mathbb{Z}'_{\mathcal{A}} = \{(a, b) \in \mathbb{Z}^2 \mid a + b \equiv 0 \pmod{2}\}$. Thus $\mathbb{Z}'_{\mathcal{A}}$ has index 2 in $\mathbb{Z}_{\mathcal{A}}$. This means that $Y_{\mathcal{A}} \neq \widehat{X}_{\mathcal{A}}$ and the map of tori

$$T_{Y_{\mathcal{A}}} \longrightarrow T_{X_{\mathcal{A}}}$$

is two-to-one, i.e., its kernel has order 2 (Exercise 2.1.4). ◇

Affine Pieces of a Projective Toric Variety. So far, our treatment of projective toric varieties has used lattice points and toric ideals. Where are the semigroups? There are actually lots of semigroups, one for each affine piece of $X_{\mathcal{A}} \subseteq \mathbb{P}^{s-1}$.

The affine open set $U_i = \mathbb{P}^{s-1} \setminus \mathbf{V}(x_i)$ contains the torus $T_{\mathbb{P}^{s-1}}$. Thus

$$T_{X_{\mathcal{A}}} = X_{\mathcal{A}} \cap T_{\mathbb{P}^{s-1}} \subseteq X_{\mathcal{A}} \cap U_i.$$

Since $X_{\mathcal{A}}$ is the Zariski closure of $T_{X_{\mathcal{A}}}$ in \mathbb{P}^{s-1} , it follows that $X_{\mathcal{A}} \cap U_i$ is the Zariski closure of $T_{X_{\mathcal{A}}}$ in $U_i \simeq \mathbb{C}^{s-1}$. Thus $X_{\mathcal{A}} \cap U_i$ is an affine toric variety.

Given $\mathcal{A} = \{m_1, \dots, m_s\} \subseteq M_{\mathbb{R}}$, the affine semigroup associated to $X_{\mathcal{A}} \cap U_i$ is easy to determine. Recall that $U_i \simeq \mathbb{C}^{s-1}$ is given by

$$(a_1, \dots, a_s) \longmapsto (a_1/a_i, \dots, a_{i-1}/a_i, a_{i+1}/a_i, \dots, a_s/a_i).$$

Combining this and $\chi^{m_j}/\chi^{m_i} = \chi^{m_j-m_i}$ with the map (2.1.2), we see that $X_{\mathcal{A}} \cap U_i$ is the Zariski closure of the image of the map

$$T_N \longrightarrow \mathbb{C}^{s-1}$$

given by

$$(2.1.5) \quad t \longmapsto (\chi^{m_1-m_i}(t), \dots, \chi^{m_{i-1}-m_i}(t), \chi^{m_{i+1}-m_i}(t), \dots, \chi^{m_s-m_i}(t)).$$

If we set $\mathcal{A}_i = \mathcal{A} - m_i = \{m_j - m_i \mid j \neq i\}$, it follows that

$$X_{\mathcal{A}} \cap U_i = Y_{\mathcal{A}_i} = \text{Spec}(\mathbb{C}[\mathbb{S}_i]),$$

where $\mathbb{S}_i = \mathbb{N}\mathcal{A}_i$ is the affine semigroup generated by \mathcal{A}_i . We have thus proved the following result.

Proposition 2.1.8. *Let $X_{\mathcal{A}} \subseteq \mathbb{P}^{s-1}$ for $\mathcal{A} = \{m_1, \dots, m_s\} \subseteq M_{\mathbb{R}}$. Then the affine piece $X_{\mathcal{A}} \cap U_i$ is the affine toric variety*

$$X_{\mathcal{A}} \cap U_i = Y_{\mathcal{A}_i} = \text{Spec}(\mathbb{C}[\mathbb{S}_i])$$

where $\mathcal{A}_i = \mathcal{A} - m_i$ and $\mathbb{S}_i = \mathbb{N}\mathcal{A}_i$. □

We also note that the results of Chapter 1 imply that the torus of $X_{\mathcal{A}_i}$ has character lattice $\mathbb{Z}\mathcal{A}_i$. Yet the torus is $T_{X_{\mathcal{A}}}$, which has character lattice $\mathbb{Z}'\mathcal{A}$ by Proposition 2.1.6. These are consistent since $\mathbb{Z}\mathcal{A}_i = \mathbb{Z}'\mathcal{A}$ for all i .

Besides describing the affine pieces $X_{\mathcal{A}} \cap U_i$ of $X_{\mathcal{A}} \subset \mathbb{P}^{s-1}$, we can also describe how they patch together. In other words, we can give a completely toric description of the inclusions

$$X_{\mathcal{A}} \cap U_i \supseteq X_{\mathcal{A}} \cap U_i \cap U_j \subseteq X_{\mathcal{A}} \cap U_j$$

when $i \neq j$. For instance, $U_i \cap U_j$ consists of all points of $X_{\mathcal{A}} \cap U_i$ where $x_j/x_i \neq 0$. In terms of $X_{\mathcal{A}} \cap U_i = \text{Spec}(\mathbb{C}[\mathbb{S}_i])$, this means those points where $\chi^{m_j-m_i} \neq 0$. Thus

$$(2.1.6) \quad X_{\mathcal{A}} \cap U_i \cap U_j = \text{Spec}(\mathbb{C}[\mathbb{S}_i])_{\chi^{m_j-m_i}} = \text{Spec}(\mathbb{C}[\mathbb{S}_i]_{\chi^{m_j-m_i}}),$$

so that if we set $m = m_j - m_i$, then the inclusion $X_{\mathcal{A}} \cap U_i \cap U_j \subseteq X_{\mathcal{A}} \cap U_i$ can be written

$$(2.1.7) \quad \text{Spec}(\mathbb{C}[\mathbb{S}_i])_{\chi^m} \subseteq \text{Spec}(\mathbb{C}[\mathbb{S}_i]).$$

This looks very similar to the inclusion constructed in (1.3.4) using faces of cones. We will see in §2.3 that this is no accident.

We next say a few words about how the polytope $P = \text{Conv}(\mathcal{A}) \subseteq M_{\mathbb{R}}$ relates to $X_{\mathcal{A}}$. As we will learn in §2.2, the dimension of P is the dimension of the smallest affine subspace of $M_{\mathbb{R}}$ containing P , which is the same as the smallest affine subspace of $M_{\mathbb{R}}$ containing \mathcal{A} . It follows from Proposition 2.1.6 that

$$\dim X_{\mathcal{A}} = \dim P.$$

Furthermore, the vertices of P give an especially efficient affine covering of $X_{\mathcal{A}}$.

Proposition 2.1.9. Given $\mathcal{A} = \{m_1, \dots, m_s\} \subseteq M$, let $P = \text{Conv}(\mathcal{A}) \subseteq M_{\mathbb{R}}$ and set $J = \{j \in \{1, \dots, s\} \mid m_j \text{ is a vertex of } P\}$. Then

$$X_{\mathcal{A}} = \bigcup_{j \in J} X_{\mathcal{A}} \cap U_j.$$

Proof. We will prove that if $i \in \{1, \dots, s\}$, then $X_{\mathcal{A}} \cap U_i \subseteq X_{\mathcal{A}} \cap U_j$ for some $j \in J$. The discussion of polytopes from §2.2 below implies that

$$P \cap M_{\mathbb{Q}} = \left\{ \sum_{j \in J} r_j m_j \mid r_j \in \mathbb{Q}_{\geq 0}, \sum_{j \in J} r_j = 1 \right\}.$$

Given $i \in \{1, \dots, s\}$, we have $m_i \in P \cap M$, so that m_i is a convex \mathbb{Q} -linear combination of the vertices m_j . Clearing denominators, we get integers $k > 0$ and $k_j \geq 0$ such that

$$k m_i = \sum_{j \in J} k_j m_j, \quad \sum_{j \in J} k_j = k.$$

Thus $\sum_{j \in J} k_j (m_j - m_i) = 0$, which implies that $m_i - m_j \in S_i$ when $k_j > 0$. Fix such a j . Then $\chi^{m_j - m_i} \in \mathbb{C}[S_i]$ is invertible, so $\mathbb{C}[S_i]_{\chi^{m_j - m_i}} = \mathbb{C}[S_i]$. By (2.1.6), $X_{\mathcal{A}} \cap U_i \cap U_j = \text{Spec}(\mathbb{C}[S_i]) = X_{\mathcal{A}} \cap U_i$, giving $X_{\mathcal{A}} \cap U_i \subseteq X_{\mathcal{A}} \cap U_j$. \square

Projective Normality. An irreducible variety $V \subseteq \mathbb{P}^n$ is called *projectively normal* if its affine cone $\widehat{V} \subseteq \mathbb{C}^{n+1}$ is normal. A projectively normal variety is always normal (Exercise 2.1.5). Here is an example to show that the converse can fail.

Example 2.1.10. Let $\mathcal{A} \subseteq \mathbb{Z}^2$ consist of the columns of the matrix

$$\begin{pmatrix} 4 & 3 & 1 & 0 \\ 0 & 1 & 3 & 4 \end{pmatrix},$$

giving the Laurent monomials s^4, s^3t, st^3, t^4 . The polytope $P = \text{Conv}(\mathcal{A})$ is the line segment connecting $(4, 0)$ and $(0, 4)$, with vertices corresponding to s^4 and t^4 . The affine piece of $X_{\mathcal{A}}$ corresponding to s^4 has coordinate ring

$$\mathbb{C}[s^3t/s^4, st^3/s^4, t^4/s^4] = \mathbb{C}[t/s, (t/s)^3, (t/s)^4] = \mathbb{C}[t/s],$$

which is normal since it is a polynomial ring. Similarly, one sees that the coordinate ring corresponding to t^4 is $\mathbb{C}[s/t]$, also normal. These affine pieces cover $X_{\mathcal{A}}$ by Proposition 2.1.9, so that $X_{\mathcal{A}}$ is normal.

Since $(1, 1, 1, 1)$ is in the row space of the matrix, $Y_{\mathcal{A}}$ is the affine cone of $X_{\mathcal{A}}$ by Proposition 2.1.4. The affine variety $Y_{\mathcal{A}}$ is not normal by Example 1.3.9, so that $X_{\mathcal{A}}$ is normal but not projectively normal. \diamond

The notion of normality used in this example is a bit ad-hoc since we have not formally defined normality for projective varieties. Once we define normality for abstract varieties in Chapter 3, we will see that Example 2.1.10 is fully rigorous.

We will say more about projective normality when we explore the connection with polytopes suggested by the above results.

Exercises for §2.1.

2.1.1. Consider the set $\mathcal{P}_3 \subseteq \mathbb{Z}^{3 \times 3}$ of 3×3 permutation matrices defined in Example 2.1.3.

- Prove the claim made in Example 2.1.3 that three of the permutation matrices sum to the other three and use this to explain why $x_{123}x_{231}x_{312} - x_{132}x_{321}x_{213} \in \mathbf{I}(X_{\mathcal{P}_3})$.
- Show that $\dim X_{\mathcal{P}_3} = 4$ by computing $\mathbb{Z}'\mathcal{P}_3$.
- Conclude that $\mathbf{I}(X_{\mathcal{P}_3}) = \langle x_{123}x_{231}x_{312} - x_{132}x_{321}x_{213} \rangle$.

2.1.2. Let $\mathcal{A} \subseteq \mathbb{Z}^n$ consist of the columns of an $n \times s$ matrix A with integer entries. Prove that the conditions of Proposition 2.1.4 are equivalent to the assertion that $(1, \dots, 1) \in \mathbb{Z}^s$ lies in the row space of A over \mathbb{R} or \mathbb{Q} .

2.1.3. Given a finite set $\mathcal{A} \subseteq M$, prove that the rank of $\mathbb{Z}'\mathcal{A}$ equals the dimension of the smallest affine subspace (over \mathbb{Q} or \mathbb{R}) containing \mathcal{A} .

2.1.4. Verify the claims made in Example 2.1.7. Also compute $\mathbf{I}(Y_{\mathcal{A}})$ and check that it is not homogeneous.

2.1.5. Let $V \subseteq \mathbb{P}^n$ be projectively normal. Use (2.0.6) to prove that the affine pieces $V \cap U_i$ of V are normal.

2.1.6. Fix a finite subset $\mathcal{A} \subseteq M$. Given $m \in M$, let $\mathcal{A} + m = \{m' + m \mid m' \in \mathcal{A}\}$. This is the *translate* of \mathcal{A} by m .

- Prove that \mathcal{A} and its translate $\mathcal{A} + m$ give the same projective toric variety, i.e., $X_{\mathcal{A}} = X_{\mathcal{A} + m}$.
- Give an example to show that the affine toric varieties $Y_{\mathcal{A}}$ and $Y_{\mathcal{A} + m}$ can differ. Hint: Pick \mathcal{A} so that it lies in an affine hyperplane not containing the origin. Then translate \mathcal{A} to the origin.

2.1.7. In Proposition 2.1.4, give a direct proof that (d) \Rightarrow (c).

2.1.8. In Example 2.1.5, the rational normal curve $C_d \subseteq \mathbb{P}^d$ was parametrized using the homogeneous monomials $s^i t^j$, $i + j = d$. Here we will consider the curve parametrized by a subset of these monomials corresponding to the exponent vectors

$$\mathcal{A} = \{(a_0, b_0), \dots, (a_n, b_n)\}$$

where $a_0 > a_1 > \dots > a_n$ and $a_i + b_i = d$ for every i . This gives the projective curve $X_{\mathcal{A}} \subseteq \mathbb{P}^n$. We assume $n \geq 2$.

- If $a_0 < d$ or $a_n > 0$, explain why we can obtain the same projective curve using monomials of strictly smaller degree.
- Assume $a_0 = d$ and $a_n = 0$. Use Proposition 2.1.8 to show that C is smooth if and only if $a_1 = d - 1$ and $a_{n-1} = 1$. Hint: For one direction, it helps to remember that smooth varieties are normal.

§2.2. Lattice Points and Polytopes

Before we can begin our exploration of the rich connections between toric varieties and polytopes, we first need to study polytopes and their lattice points.

Polytopes. Recall from Chapter 1 that a polytope $P \subseteq M_{\mathbb{R}}$ is the convex hull of a finite set $S \subseteq M_{\mathbb{R}}$, i.e., $P = \text{Conv}(S)$. Similar to what we did for cones, our discussion of polytopes will omit proofs. Detailed treatments of polytopes can be found in [24, 74, 175].

The *dimension* of a polytope $P \subseteq M_{\mathbb{R}}$ is the dimension of the smallest affine subspace of $M_{\mathbb{R}}$ containing P . Given a nonzero vector u in the dual space $N_{\mathbb{R}}$ and $b \in \mathbb{R}$, we get the *affine hyperplane* $H_{u,b}$ and *closed half-space* $H_{u,b}^+$ defined by

$$H_{u,b} = \{m \in M_{\mathbb{R}} \mid \langle m, u \rangle = b\} \quad \text{and} \quad H_{u,b}^+ = \{m \in M_{\mathbb{R}} \mid \langle m, u \rangle \geq b\}.$$

A subset $Q \subseteq P$ is a *face* of P , written $Q \preceq P$, if there are $u \in N_{\mathbb{R}} \setminus \{0\}$, $b \in \mathbb{R}$ with

$$Q = H_{u,b} \cap P \quad \text{and} \quad P \subseteq H_{u,b}^+.$$

We say that $H_{u,b}$ is a *supporting affine hyperplane* in this situation. Figure 1 shows a polygon with the supporting lines of its 1-dimensional faces. The arrows in the figure indicate the vectors u .

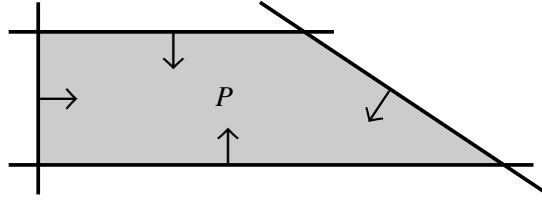

Figure 1. A polygon P and four of its supporting lines

We also regard P as a face of itself. Every face of P is again a polytope, and if $P = \text{Conv}(S)$ and $Q = H_{u,b} \cap P$ as above, then $Q = \text{Conv}(S \cap H_{u,b})$. Faces of P of special interest are *facets*, *edges* and *vertices*, which are faces of dimension $\dim P - 1$, 1 and 0 respectively. Facets will usually be denoted by the letter F .

Here are some properties of faces.

Proposition 2.2.1. *Let $P \subseteq M_{\mathbb{R}}$ be a polytope.*

- (a) P is the convex hull of its vertices.
- (b) If $P = \text{Conv}(S)$, then every vertex of P lies in S .
- (c) If Q is a face of P , then the faces of Q are precisely the faces of P lying in Q .
- (d) Every proper face $Q \prec P$ is the intersection of the facets F containing Q . \square

A polytope $P \subseteq M_{\mathbb{R}}$ can also be written as a finite intersection of closed half-spaces. The converse is true provided the intersection is bounded. In other words, if an intersection

$$P = \bigcap_{i=1}^s H_{u_i, b_i}^+$$

is bounded, then P is a polytope. Here is a famous example.

Example 2.2.2. A $d \times d$ matrix $M \in \mathbb{R}^{d \times d}$ is *doubly-stochastic* if it has nonnegative entries and its row and column sums are all 1. If we regard $\mathbb{R}^{d \times d}$ as the affine space \mathbb{R}^{d^2} with coordinates a_{ij} , then the set \mathcal{M}_d of all doubly-stochastic matrices is defined by the inequalities

$$\begin{aligned} a_{ij} &\geq 0 && \text{(all } i, j) \\ \sum_{i=1}^d a_{ij} &\geq 1, \quad \sum_{i=1}^d a_{ij} \leq 1 && \text{(all } j) \\ \sum_{j=1}^d a_{ij} &\geq 1, \quad \sum_{j=1}^d a_{ij} \leq 1 && \text{(all } i). \end{aligned}$$

(We use two inequalities to get one equality.) These inequalities easily imply that $0 \leq a_{ij} \leq 1$ for all i, j , so that \mathcal{M}_d is bounded and hence is a polytope.

Birkhoff and Von Neumann proved independently that the vertices of \mathcal{M}_d are the $d!$ permutation matrices and that $\dim \mathcal{M}_d = (d-1)^2$. In the literature, \mathcal{M}_d has various names, including the *Birkhoff polytope* and the *transportation polytope*. See [175, p. 20] for more on this interesting polytope. \diamond

When P is *full dimensional*, i.e., $\dim P = \dim M_{\mathbb{R}}$, its presentation as an intersection of closed half-spaces has an especially nice form because each facet F has a *unique* supporting affine hyperplane. We write the supporting affine hyperplane and corresponding closed half-space as

$$H_F = \{m \in M_{\mathbb{R}} \mid \langle m, u_F \rangle = -a_F\} \quad \text{and} \quad H_F^+ = \{m \in M_{\mathbb{R}} \mid \langle m, u_F \rangle \geq -a_F\},$$

where $(u_F, a_F) \in N_{\mathbb{R}} \times \mathbb{R}$ is unique up to multiplication by a positive real number. We call u_F an *inward-pointing facet normal* of the facet F . It follows that

$$(2.2.1) \quad P = \bigcap_{F \text{ facet}} H_F^+ = \{m \in M_{\mathbb{R}} \mid \langle m, u_F \rangle \geq -a_F \text{ for all facets } F \prec P\}.$$

In Figure 1, the supporting lines plus arrows determine the supporting half-planes whose intersection is the polygon P . We write (2.2.1) with minus signs in order to simplify formulas in later chapters.

Here are some important classes of polytopes.

Definition 2.2.3. Let $P \subseteq M_{\mathbb{R}}$ be a polytope of dimension d .

- P is a *simplex* or *d-simplex* if it has $d+1$ vertices.
- P is *simplicial* if every facet of P is a simplex.
- P is *simple* if every vertex is the intersection of precisely d facets.

Examples include the Platonic solids in \mathbb{R}^3 :

- A tetrahedron is a 3-simplex.
- The octahedron and icosahedron are simplicial since their facets are triangles.
- The cube and dodecahedron are simple since three facets meet at every vertex.

Polytopes P_1 and P_2 are *combinatorially equivalent* if there is a bijection

$$\{\text{faces of } P_1\} \simeq \{\text{faces of } P_2\}$$

that preserves dimensions, intersections, and the face relation \preceq . For example, simplices of the same dimension are combinatorially equivalent, and in the plane, the same holds for polygons with the same number of vertices.

Sums, Multiples, and Duals. Given a polytope $P = \text{Conv}(S)$, its multiple $rP = \text{Conv}(rS)$ is again a polytope for any $r \geq 0$. If P is defined by the inequalities

$$\langle m, u_i \rangle \geq a_i, \quad 1 \leq i \leq s,$$

then rP is given by

$$\langle m, u_i \rangle \geq ra_i, \quad 1 \leq i \leq s.$$

In particular, when P is full dimensional, then P and rP have the same inward-pointing facet normals.

The *Minkowski sum* of subsets $A_1, A_2 \subseteq M_{\mathbb{R}}$ is

$$A_1 + A_2 = \{a_1 + a_2 \mid a_1 \in A_1, a_2 \in A_2\}.$$

Given polytopes $P_1 = \text{Conv}(S_1)$ and $P_2 = \text{Conv}(S_2)$, their Minkowski sum $P_1 + P_2 = \text{Conv}(S_1 + S_2)$ is again a polytope. We also have the distributive law

$$rP + sP = (r + s)P.$$

When $P \subseteq M_{\mathbb{R}}$ is full dimensional and 0 is an interior point of P , we define the *dual* or *polar* polytope

$$P^\circ = \{u \in N_{\mathbb{R}} \mid \langle m, u \rangle \geq -1 \text{ for all } m \in P\} \subseteq N_{\mathbb{R}}.$$

Figure 2 shows an example of this in the plane.

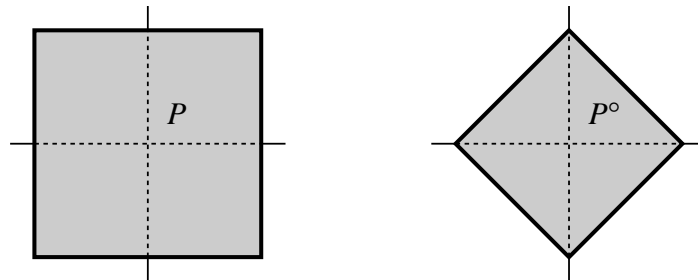

Figure 2. A polygon P and its dual P° in the plane

When we write $P = \{m \in M_{\mathbb{R}} \mid \langle m, u_F \rangle \geq -a_F, F \text{ facet}\}$ as in (2.2.1), we have $a_F > 0$ for all F since 0 is in the interior. Then P° is the convex hull of the vectors $(1/a_F)u_F \in N_{\mathbb{R}}$ (Exercise 2.2.1). We also have $(P^\circ)^\circ = P$ in this situation.

Lattice Polytopes. Now let M and N be dual lattices with associated vector spaces $M_{\mathbb{R}}$ and $N_{\mathbb{R}}$. A *lattice polytope* $P \subseteq M_{\mathbb{R}}$ is the convex hull of a finite set $S \subseteq M$. It follows easily that a polytope in $M_{\mathbb{R}}$ is a lattice polytope if and only if its vertices lie in M (Exercise 2.2.2).

Example 2.2.4. The *standard n -simplex* in \mathbb{R}^n is

$$\Delta_n = \text{Conv}(0, e_1, \dots, e_n).$$

Another simplex in \mathbb{R}^3 is $P = \text{Conv}(0, e_1, e_2, e_1 + e_2 + 3e_3)$, shown in Figure 3.

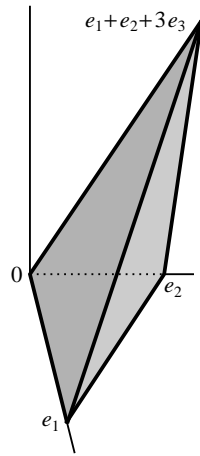

Figure 3. The simplex $P = \text{Conv}(0, e_1, e_2, e_1 + e_2 + 3e_3) \subseteq \mathbb{R}^3$

The lattice polytopes Δ_3 and P are combinatorially equivalent but will give very different projective toric varieties. \diamond

Example 2.2.5. The Birkhoff polytope defined in Example 2.2.2 is a lattice polytope relative to the lattice of integer matrices $\mathbb{Z}^{d \times d}$ since its vertices are the permutation matrices, whose entries are all 0 or 1. \diamond

One can show that faces of lattice polytopes are again lattice polytopes and that Minkowski sums and integer multiples of lattice polytopes are lattice polytopes (Exercise 2.2.2). Furthermore, every lattice polytope is an intersection of closed half-spaces defined over M , i.e., $P = \bigcap_{i=1}^s H_{u_i, b_i}^+$ where $u_i \in N$ and $b_i \in \mathbb{Z}$.

When a lattice polytope P is full dimensional, the facet presentation given in (2.2.1) has an especially nice form. If F is a facet of P , then the inward-pointing facet normals of F lie on a rational ray in $N_{\mathbb{R}}$. Let u_F denote the unique ray generator. The corresponding a_F is integral since $\langle m, u_F \rangle = -a_F$ when m is a vertex of F . It follows that

$$(2.2.2) \quad P = \{m \in M_{\mathbb{R}} \mid \langle m, u_F \rangle \geq -a_F \text{ for all facets } F \prec P\}$$

is the *unique* facet presentation of the lattice polytope P .

Example 2.2.6. Consider the square $P = \text{Conv}(\pm e_1 \pm e_2) \subseteq \mathbb{R}^2$. The facet normals of P are $\pm e_1$ and $\pm e_2$ and the facet presentation of P is given by

$$\begin{aligned}\langle m, \pm e_1 \rangle &\geq -1 \\ \langle m, \pm e_2 \rangle &\geq -1.\end{aligned}$$

Since the a_F are all equal to 1, it follows that $P^\circ = \text{Conv}(\pm e_1, \pm e_2)$ is also a lattice polytope. The polytopes P and P° are pictured in Figure 2.

It is rare that the dual of a lattice polytope is a lattice polytope—this is related to the *reflexive polytopes* that will be studied later in the book.

Example 2.2.7. The 3-simplex $P = \text{Conv}(0, e_1, e_2, e_1 + e_2 + 3e_3) \subseteq \mathbb{R}^3$ pictured in Example 2.2.4 has facet presentation

$$\begin{aligned}\langle m, e_3 \rangle &\geq 0 \\ \langle m, 3e_1 - e_3 \rangle &\geq 0 \\ \langle m, 3e_2 - e_3 \rangle &\geq 0 \\ \langle m, -3e_1 - 3e_2 + e_3 \rangle &\geq -3\end{aligned}$$

(Exercise 2.2.3). However, if we replace -3 with -1 in the last inequality, we get integer inequalities that define $(1/3)P$, which is *not* a lattice polytope. \diamond

The combinatorial type of a polytope is an interesting object of study. This leads to the question “Is every polytope combinatorially equivalent to a lattice polytope?” If the given polytope is simplicial, the answer is “yes”—just wiggle the vertices to make them rational and clear denominators to get a lattice polytope. The same argument works for simple polytopes by wiggling the facet normals. This will enable us to prove results about arbitrary simplicial or simple polytopes using toric varieties. But in general, the answer is “no”—there exist polytopes in every dimension ≥ 8 not combinatorially equivalent to any lattice polytope. An example is described in [175, Ex. 6.21].

Normal Polytopes. The connection between lattice polytopes and toric varieties comes from the lattice points of the polytope. Unfortunately, a lattice polytope might not have enough lattice points. The 3-simplex P from Example 2.2.7 has only four lattice points (its vertices), which implies that the projective toric variety $X_{P \cap \mathbb{Z}^3}$ is just \mathbb{P}^3 (Exercise 2.2.3).

We will explore two notions of what it means for a lattice polytope to “have enough lattice points.” Here is the first.

Definition 2.2.8. A lattice polytope $P \subseteq M_{\mathbb{R}}$ is *normal* if

$$(kP) \cap M + (\ell P) \cap M = ((k + \ell)P) \cap M$$

for all $k, \ell \in \mathbb{N}$.

The inclusion $(kP) \cap M + (\ell P) \cap M \subseteq ((k + \ell)P) \cap M$ is automatic. Thus normality means that all lattice points of $(k + \ell)P$ come from lattice points of kP and ℓP . In particular, a lattice polytope is normal if and only if

$$\underbrace{P \cap M + \cdots + P \cap M}_{k \text{ times}} = (kP) \cap M.$$

for all integers $k \geq 1$. In other words, normality says that P has enough lattice points to generate the lattice points in all integer multiples of P .

Lattice polytopes of dimension 1 are normal (Exercise 2.2.4). Here is another class of normal polytopes.

Definition 2.2.9. A simplex $P \subseteq M_{\mathbb{R}}$ is *basic* if P has a vertex m_0 such that the differences $m - m_0$, for vertices $m \neq m_0$ of P , form a subset of a \mathbb{Z} -basis of M .

This definition is independent of which vertex $m_0 \in P$ is chosen. The standard simplex $\Delta_n \subseteq \mathbb{R}^n$ is basic, and any basic simplex is normal (Exercise 2.2.5). More general simplicies, however, need not be normal.

Example 2.2.10. Let $P = \text{Conv}(0, e_1, e_2, e_1 + e_2 + 3e_3) \subseteq \mathbb{R}^3$. We noted earlier that the only lattice points of P are its vertices. It follows easily that

$$e_1 + e_2 + e_3 = \frac{1}{6}(0) + \frac{1}{3}(2e_1) + \frac{1}{3}(2e_2) + \frac{1}{6}(2e_1 + 2e_2 + 6e_3) \in 2P$$

is not the sum of lattice points of P . This shows that P is not normal. In particular, P is not basic. \diamond

Here is an important result on normality.

Theorem 2.2.11. Let $P \subseteq M_{\mathbb{R}}$ be a full dimensional lattice polytope of dimension $n \geq 2$. Then kP is normal for all $k \geq n - 1$.

Proof. This result was first explicitly stated in [28], though (as noted in [28]), its essential content follows from [51] and [114]. We will use ideas from [114] and [137] to show that

$$(2.2.3) \quad (kP) \cap M + P \cap M = ((k + 1)P) \cap M$$

for all integers $k \geq n - 1$. In Exercise 2.2.6 you will prove that (2.2.3) implies that kP is normal when $k \geq n - 1$. Note also that for (2.2.3), it suffices to show

$$((k + 1)P) \cap M \subseteq (kP) \cap M + P \cap M$$

since the other inclusion is obvious.

First consider the case where P is a simplex with no interior lattice points. Let the vertices of P be m_0, \dots, m_n and take $k \geq n - 1$. Then $(k + 1)P$ has vertices $(k + 1)m_0, \dots, (k + 1)m_n$, so that a point $m \in ((k + 1)P) \cap M$ is a convex combination

$$m = \sum_{i=0}^n \mu_i (k + 1)m_i, \text{ where } \mu_i \geq 0, \sum_{i=0}^n \mu_i = 1.$$

If we set $\lambda_i = (k+1)\mu_i$, then

$$m = \sum_{i=0}^n \lambda_i m_i, \text{ where } \lambda_i \geq 0, \sum_{i=0}^n \lambda_i = k+1.$$

If $\lambda_i \geq 1$ for some i , then one easily sees that $m - m_i \in (kP) \cap M$. Hence $m = (m - m_i) + m_i$ is the desired decomposition. On the other hand, if $\lambda_i < 1$ for all i , then

$$n = (n-1) + 1 \leq k+1 = \sum_{i=0}^n \lambda_i < n+1,$$

so that $k = n-1$ and $\sum_{i=0}^n \lambda_i = n$. Now consider the lattice point

$$\tilde{m} = (m_0 + \cdots + m_n) - m = \sum_{i=0}^n (1 - \lambda_i) m_i.$$

The coefficients are positive since $\lambda_i < 1$ for all i , and their sum is $\sum_{i=0}^n (1 - \lambda_i) = n+1 - n = 1$. Hence \tilde{m} is a lattice point in the interior of P since $1 - \lambda_i > 0$ for all i . This contradicts our assumption on P and completes the proof when P is a lattice simplex containing no interior lattice points.

To prove (2.2.3) for the general case, it suffices to prove that P is a finite union of n -dimensional lattice simplices with no interior lattice points (Exercise 2.2.7). For this, we use Carathéodory's theorem (see [175, Prop. 1.15]), which asserts that for a finite set $\mathcal{A} \subseteq M_{\mathbb{R}}$, we have

$$\text{Conv}(\mathcal{A}) = \bigcup \text{Conv}(\mathcal{B}),$$

where the union is over all subsets $\mathcal{B} \subseteq \mathcal{A}$ consisting of $\dim \text{Conv}(\mathcal{A}) + 1$ affinely independent elements. Thus each $\text{Conv}(\mathcal{B})$ is a simplex. This enables us to write our lattice polytope P as a finite union of n -dimensional lattice simplices.

If an n -dimensional lattice simplex $Q = \text{Conv}(w_0, \dots, w_n)$ has an interior lattice point v , then

$$Q = \bigcup_{i=0}^n Q_i, \quad Q_i = \text{Conv}(w_0, \dots, \hat{w}_i, \dots, w_n, v)$$

is a finite union of n -dimensional lattice simplices, each of which has fewer interior lattice points than Q since v becomes a vertex of each Q_i . By repeating this process on those Q_i that still have interior lattice points, we can eventually write Q and hence our original polytope P as a finite union of n -dimensional lattice simplices with no interior lattice points. You will verify the details in Exercise 2.2.7. \square

This theorem shows that for the non-normal 3-simplex P of Example 2.2.10, its multiple $2P$ is normal. Here is another consequence of Theorem 2.2.11.

Corollary 2.2.12. *Every lattice polygon $P \subseteq \mathbb{R}^2$ is normal.* \square

We can also interpret normality in terms of the cone

$$C(P) = \text{Cone}(P \times \{1\}) \subseteq M_{\mathbb{R}} \times \mathbb{R}$$

introduced in Figure 3 of Chapter 1. The key feature of this cone is that kP is the “slice” of $C(P)$ at height k , as illustrated in Figure 4. It follows that lattice points $m \in kP$ correspond to points $(m, k) \in C(P) \cap (M \times \mathbb{Z})$.

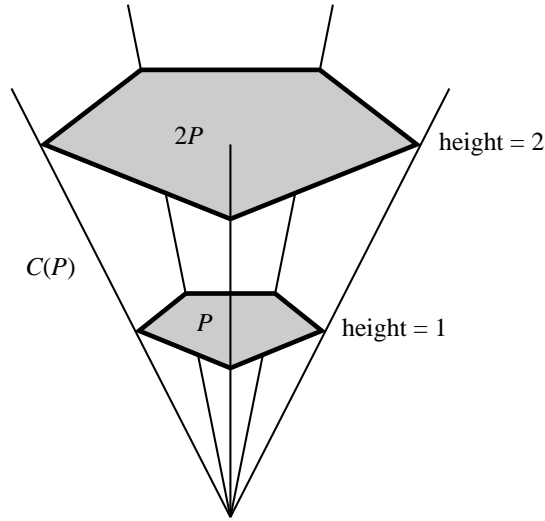

Figure 4. The cone $C(P)$ sliced at heights 1 and 2

In Exercise 2.2.8 you will show that the semigroup $C(P) \cap (M \times \mathbb{Z})$ of lattice points in $C(P)$ relates to normality as follows.

Lemma 2.2.13. *Let $P \subseteq M_{\mathbb{R}}$ be a lattice polytope. Then P is normal if and only if $(P \cap M) \times \{1\}$ generates the semigroup $C(P) \cap (M \times \mathbb{Z})$. \square*

This lemma tells us that $P \subseteq M_{\mathbb{R}}$ is normal if and only if $(P \cap M) \times \{1\}$ is the Hilbert basis of $C(P) \cap (M \times \mathbb{Z})$.

Example 2.2.14. In Example 2.2.10, the simplex $P = \text{Conv}(0, e_1, e_2, e_1 + e_2 + 3e_3)$ gives the cone $C(P) \subseteq \mathbb{R}^4$. The Hilbert basis of $C(P) \cap (M \times \mathbb{Z})$ is

$$(0, 1), (e_1, 1), (e_2, 1), (e_1 + e_2 + 3e_3, 1), (e_1 + e_2 + e_3, 2), (e_1 + e_2 + 2e_3, 2)$$

(Exercise 2.2.3). Since the Hilbert basis has generators of height greater than 1, Lemma 2.2.13 gives another proof that P is not normal.

In Exercise 2.2.9, you will generalize Lemma 2.2.13 as follows.

Lemma 2.2.15. *Let $P \subseteq M_{\mathbb{R}} \simeq \mathbb{R}^n$ be a lattice polytope of dimension $n \geq 2$ and let k_0 be the maximum height of an element of the Hilbert basis of $C(P)$. Then:*

(a) $k_0 \leq n - 1$.

(b) kP is normal for any $k \geq k_0$. \square

The Hilbert basis of the simplex P of Example 2.2.14 has maximum height 2. Then Lemma 2.2.15 gives another proof that $2P$ is normal. The paper [114] gives a version of Lemma 2.2.15 that applies to Hilbert bases of more general cones.

Very Ample Polytopes. Here is a slightly different notion of what it means for a polytope to have enough lattice points.

Definition 2.2.16. A lattice polytope $P \subseteq M_{\mathbb{R}}$ is **very ample** if for every vertex $m \in P$, the semigroup $S_{P,m} = \mathbb{N}(P \cap M - m)$ generated by the set $P \cap M - m = \{m' - m \mid m' \in P \cap M\}$ is saturated in M .

This definition relates to normal polytopes as follows.

Proposition 2.2.17. A normal lattice polytope P is very ample.

Proof. Fix a vertex $m_0 \in P$ and take $m \in M$ such that $km \in S_{P,m_0}$ for some integer $k \geq 1$. To prove that $m \in S_{P,m_0}$, write $km \in S_{P,m_0}$ as

$$km = \sum_{m' \in P \cap M} a_{m'}(m' - m_0), \quad a_{m'} \in \mathbb{N}.$$

Pick $d \in \mathbb{N}$ so that $kd \geq \sum_{m' \in P \cap M} a_{m'}$. Then

$$km + kdm_0 = \sum_{m' \in P \cap M} a_{m'}m' + (kd - \sum_{m' \in P \cap M} a_{m'})m_0 \in kdP.$$

Dividing by k gives $m + dm_0 \in dP$, which by normality implies that

$$m + dm_0 = \sum_{i=1}^d m_i, \quad m_i \in P \cap M \text{ for all } i.$$

We conclude that $m = \sum_{i=1}^d (m_i - m_0) \in S_{P,m_0}$, as desired. \square

Combining this with Theorem 2.2.11 and Corollary 2.2.12 gives the following.

Corollary 2.2.18. Let $P \subseteq M_{\mathbb{R}} \simeq \mathbb{R}^n$ be a full dimensional lattice polytope.

(a) If $\dim P \geq 2$, then kP is very ample for all $k \geq n - 1$. \square

(b) If $\dim P = 2$, then P is very ample.

Part (a) was first proved in [51]. We will soon see that very ampleness is precisely the property needed to define the toric variety of a lattice polytope.

The following example taken from [25, Ex. 5.1] shows that very ample polytopes need not be normal, i.e., the converse of Proposition 2.2.17 is false.

Example 2.2.19. Given $1 \leq i < j < k \leq 6$, let $[ijk]$ denote the vector in \mathbb{Z}^6 with 1 in positions i, j, k and 0 elsewhere. Thus $[123] = (1, 1, 1, 0, 0, 0)$. Then let

$$\mathcal{A} = \{[123], [124], [135], [146], [156], [236], [245], [256], [345], [346]\} \subseteq \mathbb{Z}^6.$$

The lattice polytope $P = \text{Conv}(\mathcal{A})$ lies in the affine hyperplane of \mathbb{R}^6 where the coordinates sum to 3. As explained in [25], this configuration can be interpreted in terms of a triangulation of the real projective plane.

The points of \mathcal{A} of P are the only lattice points of P (Exercise 2.2.10), so that \mathcal{A} is the set of vertices of P . Number the points of \mathcal{A} as m_1, \dots, m_{10} . Then

$$(1, 1, 1, 1, 1, 1) = \frac{1}{5} \sum_{i=1}^{10} m_i = \sum_{i=1}^{10} \frac{1}{10} (2m_i)$$

shows that $v = (1, 1, 1, 1, 1, 1) \in 2P$. Since v is not a sum of lattice points of P (when $[ijk] \in \mathcal{A}$, the vector $v - [ijk]$ is not in \mathcal{A}), we conclude that P is not a normal polytope.

Showing that P is very ample takes more work. The first step is to prove that $\mathcal{A} \times \{1\} \cup \{(v, 2)\} \subseteq \mathbb{R}^6 \times \mathbb{R}$ is a Hilbert basis of the semigroup $C(P) \cap \mathbb{Z}^7$, where $C(P) \subseteq \mathbb{R}^6 \times \mathbb{R}$ is the cone over $P \times \{1\}$. We used the software 4ti2 [83].

Now fix i and let S_{P, m_i} be the semigroup generated by the $m_j - m_i$. Take $m \in \mathbb{Z}^6$ such that $km \in S_{P, m_i}$. As in the proof of Proposition 2.2.17, this implies that $m + dm_i \in dP$ for some $d \in \mathbb{N}$. Thus $(m + dm_i, d) \in C(P) \cap \mathbb{Z}^7$. Expressing this in terms of the above Hilbert basis easily implies that

$$m = a(v - 2m_i) + \sum_{j=1}^{10} a_j(m_j - m_i), \quad a, a_j \in \mathbb{N}.$$

If we can show that $v - 2m_i \in S_{P, m_i}$, then $m \in S_{P, m_i}$ follows immediately and proves that S_{P, m_i} is saturated. When $i = 1$, one can check that

$$v + [123] = [124] + [135] + [236],$$

which implies that

$$v - 2m_1 = (m_2 - m_1) + (m_3 - m_1) + (m_6 - m_1) \in S_{P, m_1}.$$

One obtains similar formulas for $i = 2, \dots, 10$ (Exercise 2.2.10), which completes the proof that P is very ample.

The polytope P has further interesting properties. For example, up to affine equivalence, P can be described as the convex hull of the 10 points in \mathbb{Z}^5 given by

$$\begin{aligned} &(0, 0, 0, 0, 0), (0, 0, 0, 0, 1), (0, 0, 1, 1, 0), (0, 1, 0, 1, 1), (0, 1, 1, 1, 0) \\ &(1, 0, 1, 0, 1), (1, 0, 1, 1, 1), (1, 1, 0, 0, 0), (1, 1, 0, 1, 1), (1, 1, 1, 0, 0). \end{aligned}$$

Of all 5-dimensional polytopes whose vertices lie in $\{0, 1\}^5$, this polytope has the most edges, namely 45 (see [1]). Since it has 10 vertices and $45 = \binom{10}{2}$, every pair of distinct vertices is joined by an edge. Such polytopes are *2-neighborly*. \diamond

Exercises for §2.2.

2.2.1. Let $P \subseteq M_{\mathbb{R}}$ be a polytope of maximal dimension with the origin as an interior point.

- Write $P = \{m \in M_{\mathbb{R}} \mid \langle m, u_F \rangle \geq -a_F \text{ for all facets } F\}$. Prove that $a_F > 0$ for all F and that $P^\circ = \text{Conv}(\{(1/a_F)u_F \mid F \text{ a facet}\})$.
- Prove that the dual of a simplicial polytope is simple and vice versa.

- (c) Prove that $(rP)^\circ = (1/r)P^\circ$ for all $r > 0$.
- (d) Use part (c) to construct an example of a lattice polytope whose dual is not a lattice polytope.

2.2.2. Let $P \subseteq M_{\mathbb{R}}$ be a polytope.

- (a) Prove that P is a lattice polytope if and only if the vertices of P lie in M .
- (b) Prove that P is a lattice polytope if and only if P is the convex hull of its lattice points, i.e., $P = \text{Conv}(P \cap M)$.
- (c) Prove that every face of a lattice polytope is a lattice polytope.
- (d) Prove that Minkowski sums and integer multiples of lattice polytopes are again lattice polytopes.

2.2.3. Let $P = \text{Conv}(0, e_1, e_2, e_1 + e_2 + 3e_3) \subseteq \mathbb{R}^3$ be the simplex studied in Examples 2.2.4, 2.2.7, 2.2.10 and 2.2.14.

- (a) Verify the facet presentation of P given in Example 2.2.7.
- (b) Show that the only lattice points of P are its vertices.
- (c) Show that the toric variety $X_{P \cap \mathbb{Z}^3}$ is \mathbb{P}^3 .
- (d) Show that the vectors given in Example 2.2.14 form the Hilbert basis of the semigroup $C(P) \cap (M \times \mathbb{Z})$.

2.2.4. Prove that every 1-dimensional lattice polytope is normal.

2.2.5. Recall the definition of basic simplex given in Definition 2.2.9.

- (a) Show that if a simplex satisfies Definition 2.2.9 for one vertex, then it satisfies the definition for all vertices.
- (b) Show that the standard simplex Δ_n is basic.
- (c) Prove that a basic simplex is normal.

2.2.6. Let $P \subseteq M_{\mathbb{R}} \simeq \mathbb{R}^n$ be an n -dimensional lattice polytope.

- (a) Prove that (2.2.3) implies that

$$(kP) \cap M + (\ell P) \cap M = ((k + \ell)P) \cap M$$

for all integers $k \geq n - 1$ and $\ell \geq 0$. Hint: When $\ell = 2$, we have

$$(kP) \cap M + P \cap M + P \cap M \subseteq (kP) \cap M + (2P) \cap M \subseteq ((k + 2)P) \cap M.$$

Apply (2.2.3) twice on the right.

- (b) Use part (a) to prove that kP is normal when $k \geq n - 1$ and P satisfies (2.2.3).

2.2.7. Let $P \subseteq M_{\mathbb{R}} \simeq \mathbb{R}^n$ be an n -dimensional lattice polytope.

- (a) Follow the hints given in the text to give a careful proof that P is a finite union of n -dimensional lattice simplices with no interior lattice points.
- (b) In the text, we showed that (2.2.3) holds for an n -dimensional lattice simplex with no interior lattice points. Use this and part (a) to show that (2.2.3) holds for P .

2.2.8. Prove Lemma 2.2.13.

2.2.9. In this exercise you will prove Lemma 2.2.15. As in the lemma, let k_0 be the maximum height of a generator of the Hilbert basis of $C(P)$.

- (a) Adapt the proof of Gordan's Lemma (Proposition 1.2.17) to show that if \mathcal{H} is the Hilbert basis of the semigroup of lattice points in a strongly convex cone $\text{Cone}(\mathcal{A})$, then the lattice points in the cone can be written as the union

$$\mathbb{N}\mathcal{A} \cup \bigcup_{m \in \mathcal{H}} (m + \mathbb{N}\mathcal{A}).$$

- (b) Conclude that

$$C(P) \cap (M \times \mathbb{Z}) = S \cup \bigcup_{i=1}^s ((m_i, h_i) + S),$$

where $S = \mathbb{N}((P \cap M) \times \{1\})$.

- (c) Use part (b) to show that (2.2.3) holds for $k \geq k_0$.

2.2.10. Consider the polytope $P = \text{Conv}(\mathcal{A})$ from Example 2.2.19.

- (a) Prove that \mathcal{A} is the set of lattice points of P .
 (b) Complete the proof begun in the text that P is very ample.

2.2.11. Prove that every proper face of a simplicial polytope is a simplex.

2.2.12. In Corollary 2.2.18 we proved that kP is very ample for $k \geq n - 1$ using Theorem 2.2.11 and Proposition 2.2.17. Give a direct proof of the weaker result that kP is very ample for k sufficiently large. Hint: A vertex $m \in P$ gives the cone $C_{P,m}$ generated by the semigroup $S_{P,m}$ defined in Definition 2.2.16. The cone $C_{P,m}$ is strongly convex since m is a vertex and hence $C_{P,m} \cap M$ has a Hilbert basis. Furthermore, $C_{P,m} = C_{kP,km}$ for all $k \in \mathbb{N}$. Now argue that when k is large, $(kP) \cap M - km$ contains the Hilbert basis of $C_{P,m} \cap M$. A picture will help.

2.2.13. Fix an integer $a \geq 1$ and consider the 3-simplex $P = \text{Conv}(0, ae_1, ae_2, e_3) \subseteq \mathbb{R}^3$.

- (a) Work out the facet presentation of P and verify that the facet normals can be labeled so that $u_0 + u_1 + u_2 + au_3 = 0$.
 (b) Show that P is normal. Hint: Show that $P \cap \mathbb{Z}^3 + (kP) \cap \mathbb{Z}^3 = ((k+1)P) \cap \mathbb{Z}^3$.

We will see later that the toric variety of P is the weighted projective space $\mathbb{P}(1, 1, 1, a)$.

§2.3. Polytopes and Projective Toric Varieties

Our next task is to define the toric variety of a lattice polytope. As noted in §2.2, we need to make sure that the polytope has enough lattice points. Hence we begin with very ample polytopes. Strongly convex rational polyhedral cones will play an important role in our development.

The Very Ample Case. Let $P \subseteq M_{\mathbb{R}}$ be a full dimensional very ample polytope relative to the lattice M , and let $\dim P = n$. If $P \cap M = \{m_1, \dots, m_s\}$, then $X_{P \cap M}$ is the Zariski closure of the image of the map $T_N \rightarrow \mathbb{P}^{s-1}$ given by

$$t \longmapsto (\chi^{m_1}(t), \dots, \chi^{m_s}(t)) \in \mathbb{P}^{s-1}.$$

Fix homogeneous coordinates x_1, \dots, x_s for \mathbb{P}^{s-1} .

We examine the structure of $X_{P \cap M} \subseteq \mathbb{P}^{s-1}$ using Propositions 2.1.8 and 2.1.9. For each $m_i \in P \cap M$ consider the semigroup

$$S_i = \mathbb{N}(P \cap M - m_i)$$

generated by $m_j - m_i$ for $m_j \in P \cap M$. In \mathbb{P}^{s-1} we have the affine open subset $U_i \simeq \mathbb{C}^{s-1}$ consisting of those points where $x_i \neq 0$. Proposition 2.1.8 showed that the affine open piece $X_{P \cap M} \cap U_i$ of X_P is the affine toric variety

$$X_{P \cap M} \cap U_i \simeq \text{Spec}(\mathbb{C}[S_i]),$$

and Proposition 2.1.9 showed that

$$X_{P \cap M} = \bigcup_{m_i \text{ vertex of } P} X_{P \cap M} \cap U_i.$$

Here is our first major result about $X_{P \cap M}$.

Theorem 2.3.1. *Let $X_{P \cap M}$ be the projective toric variety of the very ample polytope $P \subseteq M_{\mathbb{R}}$, and assume that P is full dimensional with $\dim P = n$.*

(a) *For each vertex $m_i \in P \cap M$, the affine piece $X_{P \cap M} \cap U_i$ is the affine toric variety*

$$X_{P \cap M} \cap U_i = U_{\sigma_i} = \text{Spec}(\mathbb{C}[\sigma_i^{\vee} \cap M])$$

where $\sigma_i \subseteq N_{\mathbb{R}}$ is the strongly convex rational polyhedral cone dual to the cone $\text{Cone}(P \cap M - m_i) \subseteq M_{\mathbb{R}}$. Furthermore, $\dim \sigma_i = n$.

(b) *The torus of $X_{P \cap M}$ has character lattice M and hence is the torus T_N .*

Proof. Let $C_i = \text{Cone}(P \cap M - m_i)$. Since m_i is a vertex, it has a supporting hyperplane $H_{u,a}$ such that $P \subseteq H_{u,a}^+$ and $P \cap H_{u,a} = \{m_i\}$. It follows that $H_{u,0}$ is a supporting hyperplane of $0 \in C_i$ (Exercise 2.3.1), so that C_i is strongly convex. It is also easy to see that $\dim C_i = \dim P$ (Exercise 2.3.1). It follows that C_i and $\sigma_i = C_i^{\vee}$ are strongly convex rational polyhedral cones of dimension n .

We have $S_i \subseteq C_i \cap M = \sigma_i^{\vee} \cap M$. By hypothesis, P is very ample, which means that $S_i \subseteq M$ is saturated. Since S_i and $C_i = \sigma_i^{\vee}$ are both generated by $P \cap M - m_i$, part (a) of Exercise 1.3.4 implies $S_i = \sigma_i^{\vee} \cap M$. (This exercise was part of the proof of the characterization of normal affine toric varieties given in Theorem 1.3.5.) Part (a) of the theorem follows immediately.

For part (b), Theorem 1.2.18 implies that T_N is the torus of U_{σ_i} since σ_i is strongly convex. Then $T_N \subseteq U_{\sigma_i} = X_{P \cap M} \cap U_i \subseteq X_{P \cap M}$ shows that T_N is also the torus of $X_{P \cap M}$. \square

The affine pieces $X_{P \cap M} \cap U_i$ and $X_{P \cap M} \cap U_j$ intersect in $X_P \cap U_i \cap U_j$. In order to describe this intersection carefully, we need to study how the cones σ_i and σ_j fit together in $N_{\mathbb{R}}$. This leads to our next topic.

The Normal Fan. The cones $\sigma_i \subseteq N_{\mathbb{R}}$ appearing in Theorem 2.3.1 fit together in a remarkably nice way, giving a structure called the *normal fan of P* .

Let $P \subseteq M_{\mathbb{R}}$ be a full dimensional lattice polytope, not necessarily very ample. Faces, facets and vertices of P will be denoted by Q , F and v respectively. Hence

we write the facet presentation of P as

$$(2.3.1) \quad P = \{m \in M_{\mathbb{R}} \mid \langle m, u_F \rangle \geq -a_F \text{ for all } F\}.$$

A vertex $v \in P$ gives cones

$$C_v = \text{Cone}(P \cap M - v) \subseteq M_{\mathbb{R}} \quad \text{and} \quad \sigma_v = C_v^{\vee} \subseteq N_{\mathbb{R}}.$$

(When $v = m_i$, these are the cones C_i and σ_i studied above.) Faces $Q \subseteq P$ containing v correspond bijectively to faces $\mathcal{Q} \subseteq C_v$ via the maps

$$(2.3.2) \quad \begin{aligned} \mathcal{Q} &\longmapsto \mathbf{Q} = \text{Cone}(\mathcal{Q} \cap M - v) \\ \mathbf{Q} &\longmapsto Q = (\mathbf{Q} + v) \cap P \end{aligned}$$

which are inverses of each other. These maps preserve dimensions, inclusions, and intersections (Exercise 2.3.2), as illustrated in Figure 5.

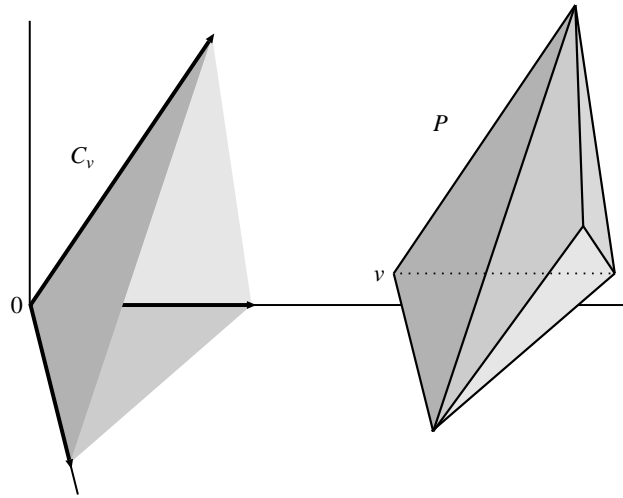

Figure 5. The cone C_v of a vertex $v \in P$

In particular, all facets of C_v come from facets of P containing v , so that

$$C_v = \{m \in M_{\mathbb{R}} \mid \langle m, u_F \rangle \geq 0 \text{ for all } F \text{ containing } v\}.$$

By the duality results of Chapter 1, it follows that the dual cone σ_v is given by

$$\sigma_v = \text{Cone}(u_F \mid F \text{ contains } v).$$

This construction generalizes to arbitrary faces $Q \preceq P$ by setting

$$\sigma_Q = \text{Cone}(u_F \mid F \text{ contains } Q).$$

Thus the cone σ_F is the ray generated by u_F , and $\sigma_P = \{0\}$ since $\{0\}$ is the cone generated by the empty set. Here is our main result about these cones.

Theorem 2.3.2. *Let $P \subseteq M_{\mathbb{R}}$ be a full dimensional lattice polytope and set $\Sigma_P = \{\sigma_Q \mid Q \preceq P\}$. Then:*

- (a) *For all $\sigma_Q \in \Sigma_P$, each face of σ_Q is also in Σ_P .*
- (b) *The intersection $\sigma_Q \cap \sigma_{Q'}$ of any two cones in Σ_P is a face of each.*

A collection of strongly convex rational polyhedral cones satisfying conditions (a) and (b) of Theorem 2.3.2 is called a *fan*. General fans will be introduced in Chapter 3. Since the cones in the above fan Σ_P are built from the inward-pointing normal vectors u_F , we call Σ_P the *normal fan* or *inner normal fan* of P .

The following easy lemma will be useful in the proof of Theorem 2.3.2.

Lemma 2.3.3. *Let Q be a face of P and let $H_{u,b}$ be a supporting affine hyperplane of P . Then $u \in \sigma_Q$ if and only if $Q \subseteq H_{u,b} \cap P$.*

Proof. First suppose that $u \in \sigma_Q$ and write $u = \sum_{Q \subseteq F} \lambda_F u_F$, $\lambda_F \geq 0$. Then setting $b = -\sum_{Q \subseteq F} \lambda_F a_F$ easily implies that $P \subseteq H_{u,b}^+$ and $Q \subseteq H_{u,b} \cap P$. Recall that the integers a_F come from the facet presentation (2.3.1).

Going the other way, suppose that $Q \subseteq H_{u,b} \cap P$. Take a vertex $v \in Q$. Then $P \subseteq H_{u,b}^+$ and $v \in H_{u,b}$ imply that $C_v \subseteq H_{u,0}^+$. Hence $u \in C_v^\vee = \sigma_v$, so that

$$u = \sum_{v \in F} \lambda_F u_F, \quad \lambda_F \geq 0.$$

Let F_0 be a facet of P containing v but not Q , and pick $p \in Q$ with $p \notin F_0$. Then $p, v \in Q \subseteq H_{u,b}$ imply that

$$\begin{aligned} b &= \langle p, u \rangle = \sum_{v \in F} \lambda_F \langle p, u_F \rangle \\ b &= \langle v, u \rangle = \sum_{v \in F} \lambda_F \langle v, u_F \rangle = -\sum_{v \in F} \lambda_F a_F, \end{aligned}$$

where the last equality uses $\langle v, u_F \rangle = -a_F$ for $v \in F$. These equations imply

$$\sum_{v \in F} \lambda_F \langle p, u_F \rangle = -\sum_{v \in F} \lambda_F a_F.$$

However, $p \notin F_0$ gives $\langle p, u_{F_0} \rangle > -a_{F_0}$, and since $\langle p, u_F \rangle \geq -a_F$ for all F , it follows that $\lambda_{F_0} = 0$ whenever $Q \not\subseteq F_0$. This gives $u \in \sigma_Q$ and completes the proof of the lemma. \square

Corollary 2.3.4. *If $Q \preceq P$ and $F \prec P$ is a facet, then $u_F \in \sigma_Q$ if and only if $Q \subseteq F$.*

Proof. One direction is obvious by the definition of σ_Q , and the other direction follows from Lemma 2.3.3 since $H_{u_F, -a_F}$ is a supporting affine hyperplane of P with $H_{u_F, -a_F} \cap P = F$. \square

Theorem 2.3.2 is an immediate corollary of the the following proposition.

Proposition 2.3.5. *Let Q and Q' be faces of a full dimensional lattice polytope $P \subseteq M_{\mathbb{R}}$. Then:*

- (a) *$Q \subseteq Q'$ if and only if $\sigma_{Q'} \subseteq \sigma_Q$.*

- (b) If $Q \subseteq Q'$, then $\sigma_{Q'}$ is a face of σ_Q , and all faces of σ_Q are of this form.
(c) $\sigma_Q \cap \sigma_{Q'} = \sigma_{Q''}$, where Q'' is the smallest face of P containing Q and Q' .

Proof. To prove part (a), note that if $Q \subseteq Q'$, then any facet containing Q' also contains Q , which implies $\sigma_{Q'} \subseteq \sigma_Q$. The other direction follows easily from Corollary 2.3.4 since every face is the intersection of the facets containing it by Proposition 2.2.1.

For part (b), fix a vertex $v \in Q$ and note that by (2.3.2), Q determines a face \mathcal{Q} of C_v . Using the duality of Proposition 1.2.10, \mathcal{Q} gives the dual face

$$\mathcal{Q}^* = C_v^\vee \cap \mathcal{Q}^\perp = \sigma_v \cap \mathcal{Q}^\perp$$

of the cone σ_v . Then using $\sigma_v = \text{Cone}(u_F \mid v \in F)$ and $\mathcal{Q} \subseteq C_v = \sigma_v^\vee$, one obtains

$$\mathcal{Q}^* = \text{Cone}(u_F \mid v \in F, \mathcal{Q} \subseteq H_{u_F,0}).$$

Since $v \in Q$, the inclusion $\mathcal{Q} \subseteq H_{u_F,0}$ is equivalent to $Q \subseteq H_{u_F,-a_F}$, which in turn is equivalent to $Q \subseteq F$. It follows that

$$(2.3.3) \quad \mathcal{Q}^* = \text{Cone}(u_F \mid Q \subseteq F) = \sigma_Q,$$

so that σ_Q is a face of σ_v , and all faces of σ_v arise in this way.

In particular, $Q \subseteq Q'$ means that $\sigma_{Q'}$ is also a face of σ_v , and since $\sigma_{Q'} \subseteq \sigma_Q$ by part (a), we see that $\sigma_{Q'}$ a face of σ_Q . Furthermore, every face of σ_Q is a face of σ_v by Proposition 1.2.6 and hence is of the form $\sigma_{Q'}$ for some face Q' . Using part (a) again, we see that $Q \subseteq Q'$, and part (b) follows.

For part (c), let Q'' be the smallest face of P containing Q and Q' . This exists because a face is the intersection of the facets containing it, so that Q'' is the intersection of all facets containing Q and Q' (if there are no such facets, then $Q'' = P$). By part (b) $\sigma_{Q''}$ is a facet of both σ_Q and $\sigma_{Q'}$. Thus $\sigma_{Q''} \subseteq \sigma_Q \cap \sigma_{Q'}$.

It remains to prove the opposite inclusion. If $\sigma_Q \cap \sigma_{Q'} = \{0\} = \sigma_P$, then $Q'' = P$ and we are done. If $\sigma_Q \cap \sigma_{Q'} \neq \{0\}$, any nonzero u in the intersection lies in both σ_Q and $\sigma_{Q'}$. The proof of Proposition 2.3.6 given below will show that $H_{u,b}$ is a supporting affine hyperplane of P for some $b \in \mathbb{R}$. By Lemma 2.3.3, $u \in \sigma_Q$ and $u \in \sigma_{Q'}$ imply that Q and Q' lie in $H_{u,b} \cap P$. The latter is a face of P containing Q and Q' , so that $Q'' \subseteq H_{u,b} \cap P$ since Q'' is the smallest such face. Applying Lemma 2.3.3 again, we see that $u \in \sigma_{Q''}$. \square

Proposition 2.3.5 shows that there is a bijective correspondence between faces of P and cones of the normal fan Σ_P . Here are some further properties of this correspondence.

Proposition 2.3.6. *Let $P \subseteq M_{\mathbb{R}}$ be a full dimensional lattice polytope of dimension n and consider the cones σ_Q in the normal fan Σ_P of P . Then:*

- (a) $\dim Q + \dim \sigma_Q = n$ for all faces $Q \preceq P$.

$$(b) N_{\mathbb{R}} = \bigcup_{v \text{ vertex of } P} \sigma_v = \bigcup_{\sigma_Q \in \Sigma_P} \sigma_Q.$$

Proof. Suppose $Q \preceq P$ and take a vertex v of Q . By (2.3.2) this gives a face Q of the cone C_v , which has a dual face Q^* of the dual cone $C_v^\vee = \sigma_v$. Since $Q^* = \sigma_Q$ by (2.3.3), we have

$$\dim Q + \dim \sigma_Q = \dim Q + \dim Q^* = n,$$

where the first equality uses Exercise 2.3.2 and the second follows from Proposition 1.2.10. This proves part (a). For part (b), let $u \in N_{\mathbb{R}}$ be nonzero and set $b = \min\{\langle v, u \rangle \mid v \text{ vertex of } P\}$. Then $P \subseteq H_{u,b}^+$ and $v \in H_{u,b}$ for at least one vertex of P , so that $u \in \sigma_v$ by Lemma 2.3.3. The final equality of part (b) follows immediately. \square

A fan satisfying the condition of part (b) of Proposition 2.3.6 is called *complete*. Thus the normal fan of a lattice polytope is always complete. We will learn more about complete fans in Chapter 3.

In general, multiplying a polytope by a positive integer has no effect on its normal fan, and the same is true for translations by lattice points. We record these properties in the following proposition (Exercise 2.3.3).

Proposition 2.3.7. *Let $P \subseteq M_{\mathbb{R}}$ be a full dimensional lattice polytope. Then for any lattice point $m \in M$ and any integer $k \geq 1$, the polytopes $m + P$ and kP have the same normal fan as P .* \square

Examples of Normal Fans. Here are some examples of normal fans.

Example 2.3.8. The 2-simplex $\Delta_2 \subseteq \mathbb{R}^2$ has vertices $0, e_1, e_2$. Let $P = k\Delta_2$ for some positive integer k . Figure 6 shows P and its normal fan Σ_P . At each vertex v_i

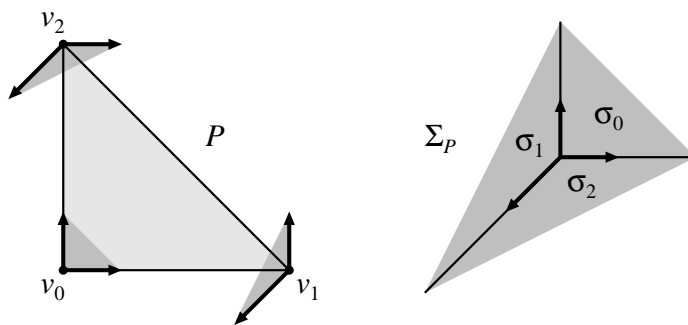

Figure 6. The triangle $P = k\Delta_2 \subseteq \mathbb{R}^2$ and its normal fan Σ_P

of P , we have drawn the normal vectors of the facets containing v_i and shaded the cone σ_i they generate. The reassembled cones appear on the left as Σ_P . \diamond

Example 2.3.9. Figure 7 shows a lattice hexagon P in the plane together with its normal fan. The vertices of P are labeled v_1, \dots, v_6 , with corresponding cone $\sigma_1, \dots, \sigma_6$ in the normal fan. In the figure, P is shown on the left, and at each vertex v_i , we have drawn the normal vectors of the facets containing v_i and shaded the cone σ_i they generate. On the right, these cones are assembled at the origin to give the normal fan.

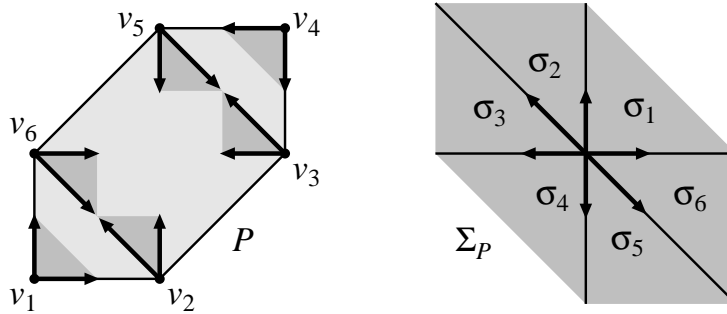

Figure 7. A lattice hexagon P and its normal fan Σ_P

Notice how one can read off the structure of P from the normal fan. For example, two cones σ_i and σ_j share a ray in Σ_P if and only if the vertices v_i and v_j lie on an edge of P . \diamond

Example 2.3.10. Consider the cube $P \subseteq \mathbb{R}^3$ with vertices $(\pm 1, \pm 1, \pm 1)$. The facet normals are $\pm e_1, \pm e_2, \pm e_3$, and the facet presentation of P is

$$\langle m, \pm e_i \rangle \geq -1.$$

The origin is an interior point of P . By Exercise 2.2.1, the facet normals are the vertices of the dual polytope P° , the octahedron in Figure 8 on the next page.

However, the facet normals also give the normal fan of P , and one can check that in the above figure, the maximal cones of the normal fan are the octants of \mathbb{R}^3 , which are just the cones over the facets of the dual polytope P° . \diamond

As noted earlier, it is rare that both P and P° are lattice polytopes. However, whenever $P \subseteq M_{\mathbb{R}}$ is a lattice polytope containing 0 as an interior point, it is still true that maximal cones of the normal fan Σ_P are the cones over the facets of $P^\circ \subseteq N_{\mathbb{R}}$ (Exercise 2.3.4).

The special behavior of the polytopes P and P° discussed in Examples 2.2.6 and 2.3.10 leads to the following definition.

Definition 2.3.11. A full dimensional lattice polytope $P \subseteq M_{\mathbb{R}}$ is *reflexive* if its facet presentation is

$$P = \{m \in M_{\mathbb{R}} \mid \langle m, u_F \rangle \geq -1 \text{ for all facets } F\}.$$

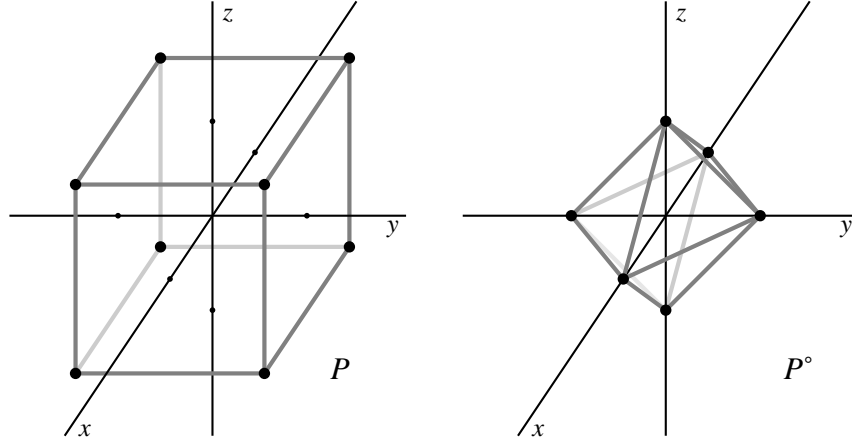

Figure 8. A cube $P \subseteq \mathbb{R}^3$ and its dual octahedron P°

If P is reflexive, then 0 is a lattice point of P and is the *only* interior lattice point of P (Exercise 2.3.5). Since $a_F = 1$ for all F , Exercise 2.2.1 implies that

$$P^\circ = \text{Conv}(u_F \mid F \text{ facet of } P).$$

Thus P° is a lattice polytope and is in fact reflexive (Exercise 2.3.5).

We will see later that reflexive polytopes lead to some very interesting toric varieties that are important for mirror symmetry.

Intersection of Affine Pieces. Let $P \subseteq M_{\mathbb{R}}$ be a full dimensional very ample polytope and set $s = |P \cap M|$. This gives

$$X_{P \cap M} \subseteq \mathbb{P}^{s-1}.$$

If $X_{P \cap M} \cap U_v$ is the affine piece corresponding a vertex $v \in P$, then

$$X_{P \cap M} \cap U_v = U_{\sigma_v} = \text{Spec}(\mathbb{C}[\sigma_v^\vee \cap M])$$

by Theorem 2.3.1. Thus the affine piece $X_{P \cap M} \cap U_v$ is the toric variety of the cone σ_v in the normal fan Σ_P of P .

Our next task is to describe the intersection of two of these affine pieces.

Proposition 2.3.12. *Let $P \subseteq M_{\mathbb{R}}$ be full dimensional and very ample. If $v \neq w$ are vertices of P and Q is the smallest face of P containing v and w , then*

$$X_{P \cap M} \cap U_v \cap U_w = U_{\sigma_Q} = \text{Spec}(\mathbb{C}[\sigma_Q^\vee \cap M])$$

and the inclusions

$$X_{P \cap M} \cap U_v \supseteq X_{P \cap M} \cap U_v \cap U_w \subseteq X_{P \cap M} \cap U_w$$

can be written

$$(2.3.4) \quad U_{\sigma_v} \supseteq (U_{\sigma_v})_{\chi^{w-v}} = U_{\sigma_Q} = (U_{\sigma_w})_{\chi^{v-w}} \subseteq U_{\sigma_w}.$$

Proof. We analyzed the intersection of affine pieces of $X_{P \cap M}$ in §2.1. Translated to the notation being used here, (2.1.6) and (2.1.7) imply that

$$X_{P \cap M} \cap U_v \cap U_w = (U_{\sigma_v})_{\chi^{w-v}} = (U_{\sigma_w})_{\chi^{v-w}}.$$

Thus all we need to show is that

$$(U_{\sigma_v})_{\chi^{w-v}} = U_{\sigma_Q}.$$

However, we have $w - v \in C_v = \sigma_v^\vee$, so that $\tau = H_{w-v} \cap \sigma_v$ is a face of σ_v . In this situation, Proposition 1.3.16 and equation (1.3.4) imply that

$$(U_{\sigma_v})_{\chi^{w-v}} = U_\tau.$$

Thus the proposition will follow once we prove $\tau = \sigma_Q$, i.e., $H_{w-v} \cap \sigma_v = \sigma_Q$. Since $\sigma_Q = \sigma_v \cap \sigma_w$ by Proposition 2.3.5, it suffices to prove that

$$H_{w-v} \cap \sigma_v = \sigma_v \cap \sigma_w.$$

Let $u \in H_{w-v} \cap \sigma_v$. If $u \neq 0$, there is $b \in \mathbb{R}$ such $H_{u,b}$ is a supporting affine hyperplane of P . Then $u \in \sigma_v$ implies $v \in H_{u,b}$ by Lemma 2.3.3, so that $w \in H_{u,b}$ since $u \in H_{w-v}$. Applying Lemma 2.3.3 again, we get $u \in \sigma_w$. Going the other way, let $u \in \sigma_v \cap \sigma_w$. If $u \neq 0$, pick $b \in \mathbb{R}$ as above. Then $u \in \sigma_v \cap \sigma_w$ and Lemma 2.3.3 imply that $v, w \in H_{u,b}$, from which $u \in H_{w-v}$ follows easily. This completes the proof. \square

This proposition and Theorem 2.3.1 have the remarkable result that the normal fan Σ_P completely determines the internal structure of $X_{P \cap M}$: we build $X_{P \cap M}$ from local pieces given by the affine toric varieties U_{σ_v} , glued together via (2.3.4). We do not need the ambient projective space \mathbb{P}^{s-1} for any of this—everything we need to know is contained in the normal fan.

The Toric Variety of a Polytope. We can now give the general definition of the toric variety of a polytope.

Definition 2.3.13. Let $P \subseteq M_{\mathbb{R}}$ be a full dimensional lattice polytope. Then we define the *toric variety of P* to be

$$X_P = X_{(kP) \cap M}$$

where k is any positive integer such that kP is very ample.

Such integers k exist by Corollary 2.2.18, and if k and ℓ are two such integers, then kP and ℓP have the same normal fan by Proposition 2.3.7, namely $\Sigma_{kP} = \Sigma_{\ell P} = \Sigma_P$. It follows that while $X_{(kP) \cap M}$ and $X_{(\ell P) \cap M}$ lie in different projective spaces, they are built from the affine toric varieties U_{σ_v} glued together via (2.3.4). Once we develop the language of abstract varieties in Chapter 3, we will see that X_P is well-defined as an abstract variety.

We will often speak of X_P without regard to the projective embedding. When we want to use a specific embedding, we will say “ X_P is embedded using kP ”,

where we assume that kP is very ample. In Chapter 6 we will use the language of divisors and line bundles to restate this in terms of a divisor D_P on X_P such that kD_P is very ample precisely when kP is.

Here is a simple example to illustrate the difference between X_P as an abstract variety and X_P as sitting in a specific projective space.

Example 2.3.14. Consider the n -simplex $\Delta_n \subseteq \mathbb{R}^n$. We can define X_{Δ_n} using $k\Delta_n$ for any integer $k \geq 1$ since Δ_n is normal and hence very ample. The lattice points in $k\Delta_n$ correspond to the $s_k = \binom{n+k}{k}$ monomials of $\mathbb{C}[t_1, \dots, t_n]$ of total degree $\leq n$. This gives an embedding $X_{\Delta_n} \subseteq \mathbb{P}^{s_k-1}$. When $k = 1$, $\Delta_n \cap \mathbb{Z}^n = \{0, e_1, \dots, e_n\}$ implies that

$$X_{\Delta_n} = \mathbb{P}^n.$$

The normal fan of Δ_n is described in Exercise 2.3.6. For an arbitrary $k \geq 1$, we can regard $X_{\Delta_n} \subseteq \mathbb{P}^{s_k-1}$ as the image of the map

$$\nu_k : \mathbb{P}^n \longrightarrow \mathbb{P}^{s_k-1}$$

defined using all monomials of total degree k in $\mathbb{C}[x_0, \dots, x_n]$ (Exercise 2.3.6). It follows that this map is an embedding, usually called the *Veronese embedding*. But when we forget the embedding, the underlying toric variety is just \mathbb{P}^n .

The Veronese embedding allows us to construct some interesting affine open subsets of \mathbb{P}^n . Let $f \in \mathbb{C}[x_0, \dots, x_n]$ be nonzero and homogeneous of degree k and write $f = \sum_{|\alpha|=k} c_\alpha x^\alpha$. We write the homogeneous coordinates of \mathbb{P}^{s_k-1} as y_α for $|\alpha| = k$. Then $L = \sum_{|\alpha|=k} c_\alpha y_\alpha$ is a nonzero linear form in the variables y_α , so that $\mathbb{P}^{s_k-1} \setminus \mathbf{V}(L)$ is a copy of \mathbb{C}^{s_k-1} (Exercise 2.3.6). It follows that

$$\mathbb{P}^n \setminus \mathbf{V}(f) \simeq \nu_k(\mathbb{P}^n) \cap (\mathbb{P}^{s_k-1} \setminus \mathbf{V}(L))$$

is an affine variety (usually not toric). This shows that \mathbb{P}^n has a richer supply of affine open subsets than just the open sets $U_i = \mathbb{P}^n \setminus \mathbf{V}(x_i)$ considered earlier in the chapter. \diamond

When we explain the Proj construction of \mathbb{P}^n later in the book, we will see the intrinsic reason why $\mathbb{P}^n \setminus \mathbf{V}(f)$ is an affine open subset of \mathbb{P}^n .

Example 2.3.15. The 2-dimensional analog of the rational normal curve C_d is the *rational normal scroll* $S_{a,b}$, which is the toric variety of the polygon

$$P_{a,b} = \text{Conv}(0, ae_1, e_2, be_1 + e_2) \subseteq \mathbb{R}^2,$$

where $a, b \in \mathbb{N}$ satisfy $1 \leq a \leq b$. The polygon $P = P_{2,4}$ and its normal fan are pictured in Figure 9 on the next page.

In general, the polygon $P_{a,b}$ has $a + b + 2$ lattice points and gives the map

$$(\mathbb{C}^*)^2 \longrightarrow \mathbb{P}^{a+b+1}, \quad (s, t) \mapsto (1, s, s^2, \dots, s^a, t, st, s^2t, \dots, s^bt)$$

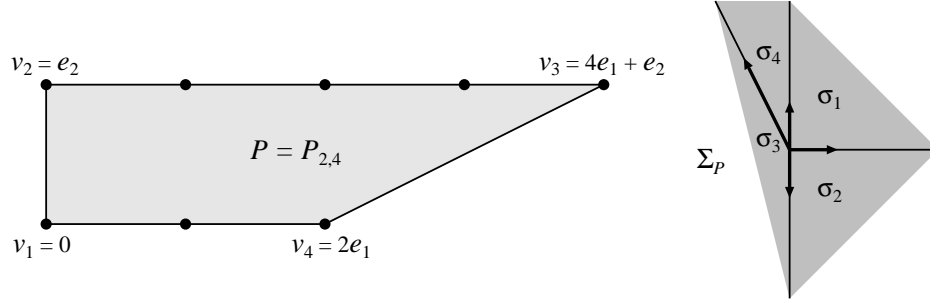

Figure 9. The polygon of a rational normal scroll and its normal fan

such that $S_{a,b} = X_{P_{a,b}}$ is the Zariski closure of the image. To describe the image, we rewrite the map as

$$\mathbb{C} \times \mathbb{P}^1 \longrightarrow \mathbb{P}^{a+b+1}, \quad (s, \lambda, \mu) \mapsto (\lambda, s\lambda, s^2\lambda, \dots, s^a\lambda, \mu, s\mu, s^2\mu, \dots, s^b\mu).$$

When $(\lambda, \mu) = (1, 0)$, the map is $s \mapsto (1, s, s^2, \dots, s^a, 0, \dots, 0)$, which is the rational normal curve C_a mapped to the first $a + 1$ coordinates of \mathbb{P}^{a+b+1} . In the same way, $(\lambda, \mu) = (0, 1)$ gives the rational normal curve C_b mapped to the last $b + 1$ coordinates of \mathbb{P}^{a+b+1} . If we think of these two curves as the “edges” of a scroll, then fixing s gives a point on each edge, and letting $(\lambda, \mu) \in \mathbb{P}^1$ vary gives the line of the scroll connecting the two points. So it really is a scroll!

An important observation is that the normal fan depends *only* on the difference $b - a$, since this determines the slope of the slanted edge of $P_{a,b}$. If we denote the difference by $r \in \mathbb{N}$, it follows that as abstract toric varieties, we have

$$X_{P_{1,r+1}} = X_{P_{2,r+2}} = X_{P_{3,r+3}} = \dots$$

since they are all constructed from the same normal fan. In Chapter 3, we will see that this is the Hirzebruch surface \mathcal{H}_r .

But if we think of the projective surface $S_{a,b} \subseteq \mathbb{P}^{a+b+1}$, then a and b have a unique meaning. For example, they have a strong influence on the defining equations of $S_{a,b}$. Let the homogeneous coordinates of \mathbb{P}^{a+b+1} be $x_0, \dots, x_a, y_0, \dots, y_b$ and consider the $2 \times (a + b)$ matrix

$$\left(\begin{array}{cccc|cccc} x_0 & x_1 & \cdots & x_{a-1} & y_0 & y_1 & \cdots & y_{b-1} \\ x_1 & x_2 & \cdots & x_a & y_1 & y_2 & \cdots & y_b \end{array} \right).$$

One can show that $\mathbf{I}(S_{a,b}) \subseteq \mathbb{C}[x_0, \dots, x_a, y_0, \dots, y_b]$ is generated by the 2×2 minors of this matrix (see [76, Ex. 9.11], for example). \diamond

Example 2.3.15 is another example of a determinantal variety, as is the rational normal curve from Example 2.0.1. Note that the rational normal curve C_d comes from the polytope $[0, d] = d\Delta_1$, where the underlying toric variety is just \mathbb{P}^1 .

Exercises for §2.3.

2.3.1. This exercise will use the same notation as the proof of Theorem 2.3.1.

- (a) Let $H_{u,a}$ be a supporting hyperplane of a vertex $m_i \in P$. Prove that $H_{u,0}$ is a supporting hyperplane of $0 \in C_i$
- (b) Prove that $\dim C_i = \dim P$.

2.3.2. Consider the maps defined in (2.3.2).

- (a) Show that these maps are inverses of each other and define a bijection between the faces of the cone C_v and the faces of P containing v .
- (b) Prove that these maps preserve dimensions, inclusions, and intersections.
- (c) Explain how this exercise relates to Exercise 2.3.1.

2.3.3. Prove Proposition 2.3.7.

2.3.4. Let $P \subseteq M_{\mathbb{R}}$ be a full dimensional lattice polytope containing 0 as an interior point, and let $P^\circ \subseteq N_{\mathbb{R}}$ be its dual polytope. Prove that the normal fan Σ_P consists of the cones over the faces of P° . Hint: Exercise 2.2.1 will be useful.

2.3.5. Let $P \subseteq M_{\mathbb{R}}$ be a reflexive polytope.

- (a) Prove that 0 is the only interior lattice point of P .
- (b) Prove that $P^\circ \subseteq N_{\mathbb{R}}$ is reflexive.

2.3.6. This exercise is concerned with Example 2.3.14

- (a) Let e_1, \dots, e_n be the standard basis of \mathbb{R}^n . Prove that the normal fan of the standard n -simplex consists of the cones $\text{Cone}(S)$ for all proper subsets $S \subseteq \{e_0, e_1, \dots, e_n\}$, where $e_0 = -\sum_{i=1}^n e_i$. Draw pictures of the normal fan for $n = 1, 2, 3$.
- (b) For an integer $k \geq 1$, show that the toric variety $X_{k\Delta_n} \subseteq \mathbb{P}^{s_k-1}$ is given by the map $\nu_k : \mathbb{P}^n \rightarrow \mathbb{P}^{s_k-1}$ defined using all monomials of total degree k in $\mathbb{C}[x_0, \dots, x_n]$.

2.3.7. Let $P \subseteq M_{\mathbb{R}} \simeq \mathbb{R}^n$ be an n -dimensional lattice polytope and let $Q \subseteq P$ be a face. Prove the following intrinsic description of the cone $\sigma_Q \in \Sigma_P$:

$$\sigma_Q = \{u \in N_{\mathbb{R}} \mid \langle m, u \rangle \leq \langle m', u \rangle \text{ for all } m \in Q, m' \in P\}.$$

2.3.8. Prove that all lattice rectangles in the plane with edges parallel to the coordinate axes have the same normal fan.

§2.4. Properties of Projective Toric Varieties

We conclude this chapter by studying when the projective toric variety X_P of a polytope P is smooth or normal.

Normality. Recall from §2.1 that a projective variety is *projectively normal* if its affine cone is normal.

Theorem 2.4.1. *Let $P \subseteq M_{\mathbb{R}}$ be a full dimensional lattice polytope. Then:*

- (a) X_P is normal.
- (b) X_P is projectively normal under the embedding given by kP if and only if kP is normal.

Proof. Part (a) is immediate since X_P is the union of affine pieces U_{σ_v} , v a vertex of P , and U_{σ_v} is normal by Theorem 1.3.5. In Chapter 3 we will give an intrinsic definition of normality that will make this argument completely rigorous.

For part (b), the discussion following (2.1.4) shows that the projective embedding of X_P given by $X_{(kP) \cap M}$ has affine cone given by $Y_{((kP) \cap M) \times \{1\}}$. By Theorem 1.3.5, this is normal if and only if the semigroup $\mathbb{N}(((kP) \cap M) \times \{1\})$ is saturated in $M \times \mathbb{Z}$, and since $((kP) \cap M) \times \{1\}$ generates the cone $C(P)$, this is equivalent to saying that $(kP) \cap M \times \{1\}$ generates the semigroup $C(P) \cap (M \times \mathbb{Z})$. Then we are done by Lemma 2.2.13. \square

Smoothness. Given the results of Chapter 1, the smoothness of X_P is equally easy to determine. We need one definition.

Definition 2.4.2. Let $P \subseteq M_{\mathbb{R}}$ be a lattice polytope.

- (a) Given a vertex v of P and an edge E containing v , let w_E be the first lattice point of E different from v encountered as one transverses E starting at v . In other words, $w_E - v$ is the ray generator of the ray $\text{Cone}(E - v)$.
- (b) P is **smooth** if for every vertex v , the vectors $w_E - v$, where E is an edge of P containing v , form a subset of a basis of M . In particular, if $\dim P = \dim M_{\mathbb{R}}$, then the vectors $w_E - v$ form a basis of M .

We can now characterize when X_P is smooth.

Theorem 2.4.3. Let $P \subseteq M_{\mathbb{R}}$ be a full dimensional lattice polytope. Then the following are equivalent:

- (a) X_P is a smooth projective variety.
- (b) Σ_P is a smooth fan, meaning that every cone in Σ_P is smooth in the sense of Definition 1.2.16.
- (c) P is a smooth polytope.

Proof. Smoothness is a local condition, so that a variety is smooth if and only if its local pieces are smooth. Thus X_P is smooth if and only if U_{σ_v} is smooth for every vertex v of P , and U_{σ_v} is smooth if and only if σ_v is smooth by Theorem 1.3.12. Since faces of smooth cones are smooth and Σ_P consists of the σ_v and their faces, the equivalence (a) \Leftrightarrow (b) follows immediately.

For (b) \Leftrightarrow (c), first observe that σ_v is smooth if and only if its dual $C_v = \sigma_v^{\vee}$ is smooth. The discussion following (2.3.2) makes it easy to see that the ray generators of C_v are the vectors $w_E - v$ from Definition 2.4.2. It follows immediately that P is smooth if and only if C_v is smooth for every vertex v , and we are done. \square

The theorem makes it easy to check the smoothness of simple examples such as the toric variety of the hexagon in Example 2.3.9 or the rational normal scroll $S_{a,b}$ of Example 2.3.15 (Exercise 2.4.1).

We also note the following useful fact, which you will prove in Exercise 2.4.2.

Proposition 2.4.4. *Every smooth full dimensional lattice polytope $P \subseteq M_{\mathbb{R}}$ is very ample.* \square

One can also ask whether every smooth lattice polytope is normal. This is an important open problem in the study of lattice polytopes.

Here is an example of a smooth reflexive polytope whose dual is not smooth.

Example 2.4.5. Let $P = (n + 1)\Delta_n - (1, \dots, 1) \subseteq \mathbb{R}^n$, where Δ_n is the standard n -simplex. Proposition 2.3.7 implies that P and Δ_n have the same normal fan, so that P and X_P are smooth. Note also that $X_P = X_{\Delta_n} = \mathbb{P}^n$.

The polytope P has the following interesting properties (Exercise 2.4.3). First, P has the facet presentation

$$\begin{aligned} x_i &\geq -1, \quad i = 1, \dots, n, \\ -x_1 - \dots - x_n &\geq -1, \end{aligned}$$

so that P is reflexive with dual

$$P^\circ = \text{Conv}(e_0, e_1, \dots, e_n), \quad e_0 = -e_1 - \dots - e_n.$$

The normal fan of P° consists of cones over the faces of P . In particular, the cone of Σ_{P° corresponding to the vertex $e_0 \in P^\circ$ is the cone

$$\sigma_{e_0} = \text{Conv}(v_1, \dots, v_n), \quad v_i = e_0 + (n + 1)e_i.$$

Figure 10 shows P and the cone σ_{e_0} when $n = 2$.

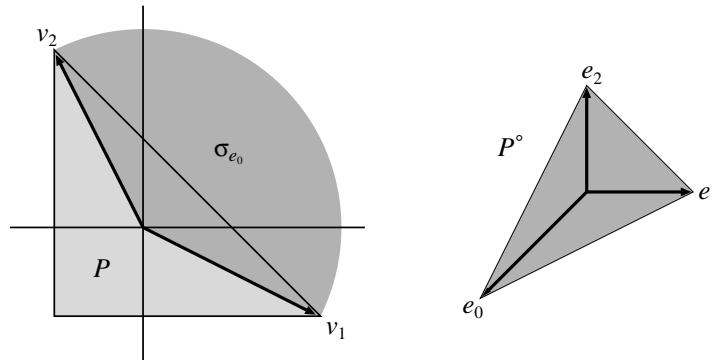

Figure 10. The cone σ_{e_0} of the normal fan of P°

For general n , observe that $v_i - v_j = (n + 1)(e_i - e_j)$. This makes it easy to see that $\mathbb{Z}v_1 + \dots + \mathbb{Z}v_n$ has index $(n + 1)^{n-1}$ in \mathbb{Z}^n . Thus σ_{e_0} is not smooth when $n \geq 2$. It follows that the “dual” toric variety X_{P° is singular for $n \geq 2$. Later we will construct X_{P° as the quotient of \mathbb{P}^n under the action of a finite group $G \simeq (\mathbb{Z}/(n + 1)\mathbb{Z})^{n-1}$. \diamond

Example 2.4.6. Consider $P = \text{Conv}(0, 2e_1, e_2) \subseteq \mathbb{R}^2$. Since P is very ample, the lattice points $P \cap \mathbb{Z}^2 = \{0, e_1, 2e_1, e_2\}$ give the map $(\mathbb{C}^*)^2 \rightarrow \mathbb{P}^3$ defined by

$$(s, t) \longmapsto (1, s, s^2, t)$$

such that X_P is the Zariski closure of the image. If \mathbb{P}^3 has homogeneous coordinates y_0, y_1, y_2, y_3 , then we have

$$X_P = \mathbf{V}(y_0 y_2 - y_1^2) \subseteq \mathbb{P}^3.$$

Comparing this to Example 2.0.5, we see that X_P is the weighted projective space $\mathbb{P}(1, 1, 2)$. Later we will learn the systematic reason why this is true.

The variety X_P is not smooth. By working on the affine piece $X_P \cap U_3$, one can check directly that $(0, 0, 0, 1)$ is a singular point of X_P .

We can also use Theorem 2.4.3 and the normal fan of P , shown in Figure 11. One can check that the cones σ_0 and σ_1 are smooth, but σ_2 is not, so that Σ_P

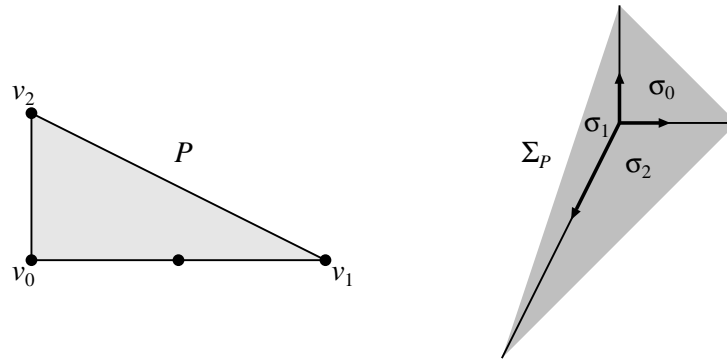

Figure 11. The polygon giving $\mathbb{P}(1, 1, 2)$ and its normal fan

is not a smooth fan. In terms of P , note that the vectors from v_2 to the first lattice points along the edges containing v_2 do not generate \mathbb{Z}^2 . Either way, Theorem 2.4.3 implies that X_P is not smooth.

If you look carefully, you will see that σ_2 is the *only* nonsmooth cone of the normal fan Σ_P . Once we study the correspondence between cones and orbits in Chapter 3, we will see that the non-smooth cone σ_2 corresponds to the singular point $(0, 0, 0, 1)$ of X_P . \diamond

Products of Projective Toric Varieties. Our final task is to understand the toric variety of a product of polytopes. Let $P_i \subseteq (M_i)_{\mathbb{R}} \simeq \mathbb{R}^{n_i}$ be lattice polytopes with $\dim P_i = n_i$ for $i = 1, 2$. This gives a lattice polytope $P_1 \times P_2 \subseteq (M_1 \times M_2)_{\mathbb{R}}$ of dimension $n_1 + n_2$.

Replacing P_1 and P_2 with suitable multiples, we can assume that P_1 and P_2 are very ample. This gives projective embeddings

$$X_{P_i} \hookrightarrow \mathbb{P}^{s_i-1}, \quad s_i = |P_i \cap M_i|,$$

so that by Proposition 2.0.4, $X_{P_1} \times X_{P_2}$ is a subvariety of $\mathbb{P}^{s_1-1} \times \mathbb{P}^{s_2-1}$. Using the Segre embedding

$$\mathbb{P}^{s_1-1} \times \mathbb{P}^{s_2-1} \hookrightarrow \mathbb{P}^{s-1}, \quad s = s_1 s_2,$$

we get an embedding

$$(2.4.1) \quad X_{P_1} \times X_{P_2} \hookrightarrow \mathbb{P}^{s-1}.$$

We can understand this projective variety as follows.

Theorem 2.4.7. *If P_1 and P_2 are very ample, then*

(a) $P_1 \times P_2 \subseteq (M_1 \times M_2)_{\mathbb{R}}$ is a very ample polytope with lattice points

$$(P_1 \times P_2) \cap (M_1 \times M_2) = (P_1 \cap M_1) \times (P_2 \cap M_2).$$

Thus the integer s defined above is $s = |(P_1 \times P_2) \cap (M_1 \times M_2)|$.

(b) The image of the embedding $X_{P_1} \times X_{P_2} \hookrightarrow \mathbb{P}^{s-1}$ coming from the very ample polytope $P_1 \times P_2$ equals the image of (2.4.1).

(c) $X_{P_1 \times P_2} \simeq X_{P_1} \times X_{P_2}$.

Proof. For part (a), the assertions about lattice points are clear. The vertices of $P_1 \times P_2$ consist of ordered pairs (v_1, v_2) where v_i is a vertex of P_i (Exercise 2.4.4). Given such a vertex, we have

$$(P_1 \times P_2) \cap (M_1 \times M_2) - (v_1, v_2) = (P_1 \cap M_1 - v_1) \times (P_2 \cap M_2 - v_2).$$

Since P_i is very ample, we know that $\mathbb{N}(P_i \cap M_i - v_i)$ is saturated in M_i . From here, it follows easily that $P_1 \times P_2$ is very ample.

For part (b), let T_{N_i} be the torus of X_{P_i} . Since T_{N_i} is Zariski dense in X_{P_i} , it follows that $T_{N_1} \times T_{N_2}$ is Zariski dense in $X_{P_1} \times X_{P_2}$ (Exercise 2.4.4). When combined with the Segre embedding, it follows that $X_{P_1} \times X_{P_2}$ is the Zariski closure of the image of the map

$$T_{N_1} \times T_{N_2} \longrightarrow \mathbb{P}^{s_1 s_2 - 1}$$

given by the characters $\chi^m \chi^{m'}$, where m ranges over the s_1 elements of $P_1 \cap M_1$ and m' ranges over the s_2 elements of $P_2 \cap M_2$. When we identify $T_{N_1} \times T_{N_2}$ with $T_{N_1 \times N_2}$, the product $\chi^m \chi^{m'}$ becomes the character $\chi^{(m, m')}$, so that the above map coincides with the map

$$T_{N_1 \times N_2} \longrightarrow \mathbb{P}^{s-1}$$

coming from the product polytope $P_1 \times P_2 \subseteq (M_1 \times M_2)_{\mathbb{R}}$. Part (b) follows, and part (c) is an immediate consequence. \square

Here is an obvious example.

Example 2.4.8. Since \mathbb{P}^n is the toric variety of the standard n -simplex Δ_n , it follows that $\mathbb{P}^n \times \mathbb{P}^m$ is the toric variety of $\Delta_n \times \Delta_m$.

This also works for more than two factors. Thus $\mathbb{P}^1 \times \mathbb{P}^1 \times \mathbb{P}^1$ is the toric variety of the cube pictured in Figure 8. \diamond

To have a complete theory of products, we need to know what happens to the normal fan. Here is the result, whose proof is left to the reader (Exercise 2.4.5).

Proposition 2.4.9. Let $P_i \subseteq (M_i)_{\mathbb{R}}$ be full dimensional lattice polytopes for $i = 1, 2$. Then

$$\Sigma_{P_1 \times P_2} = \Sigma_{P_1} \times \Sigma_{P_2}. \quad \square$$

Here is an easy example.

Example 2.4.10. The normal fan of an interval $[a, b] \subseteq \mathbb{R}$, where $a < b$ in \mathbb{Z} , is given by

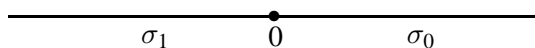

The corresponding toric variety is \mathbb{P}^1 . The cartesian product of two such intervals is a lattice rectangle whose toric variety is $\mathbb{P}^1 \times \mathbb{P}^1$ by Theorem 2.4.7. If we set $\sigma_{ij} = \sigma_i \times \sigma_j$, then Proposition 2.4.9 gives the normal fan given in Figure 12.

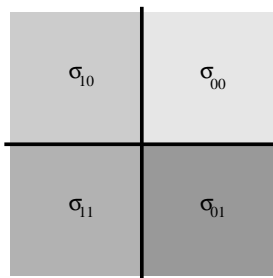

Figure 12. The normal fan of a lattice rectangle giving $\mathbb{P}^1 \times \mathbb{P}^1$

We will revisit this example in Chapter 3 when we construct toric varieties directly from fans. \diamond

Proposition 2.4.9 suggests a different way to think about the product. Let v_i range over the vertices of P_i . Then the σ_{v_i} are the maximal cones in the normal fan Σ_{P_i} , which implies that

$$(2.4.2) \quad X_{P_i} = \bigcup_{v_i} U_{\sigma_{v_i}}.$$

Thus

$$\begin{aligned} X_{P_1} \times X_{P_2} &= \left(\bigcup_{v_1} U_{\sigma_{v_1}} \right) \times \left(\bigcup_{v_2} U_{\sigma_{v_2}} \right) \\ &= \bigcup_{(v_1, v_2)} U_{\sigma_{v_1}} \times U_{\sigma_{v_2}} \\ &= \bigcup_{(v_1, v_2)} U_{\sigma_{v_1} \times \sigma_{v_2}} \\ &= \bigcup_{(v_1, v_2)} U_{\sigma_{(v_1, v_2)}} = X_{P_1 \times P_2}. \end{aligned}$$

In this sequence of equalities, the first follows from (2.4.2), the second is obvious, the third uses Exercise 1.3.13, the fourth uses Proposition 2.4.9, and the last follows since (v_1, v_2) ranges over all vertices of $P_1 \times P_2$.

This argument shows that we can construct cartesian products of varieties using affine open covers, which reduces to the cartesian product of affine varieties defined in Chapter 1. We will use this idea in Chapter 3 to define the cartesian product of abstract varieties.

Exercises for §2.4.

2.4.1. Show that the hexagon $P = \text{Conv}(0, e_1, e_2, 2e_1 + e_2, e_1 + 2e_2, 2e_1 + 2e_2)$ pictured in Figure 6 and the trapezoid $P_{a,b}$ pictured in Figure 9 are smooth polygons. Also, of the polytopes shown in Figure 8, determine which ones are smooth.

2.4.2. Prove Proposition 2.4.4.

2.4.3. Consider the polytope $P = (n+1)\Delta_n - (1, \dots, 1)$ from Example 2.4.5.

- Verify the facet presentation of P given in the example.
- What is the facet presentation of P° ? Hint: You know the vertices of P .
- Let $v_i = e_0 + (n+1)e_i$, where $i = 1, \dots, n$ and $e_0 = -e_1 - \dots - e_n$, and then set $L = \mathbb{Z}v_1 + \dots + \mathbb{Z}v_n$. Use the hint given in the text to prove $\mathbb{Z}^n/L \simeq (\mathbb{Z}/(n+1)\mathbb{Z})^{n-1}$. This shows that the index of L in \mathbb{Z}^n is $(n+1)^{n-1}$, as claimed in the text.

2.4.4. Let $P_i \subseteq (M_i)_{\mathbb{R}} \simeq \mathbb{R}^{m_i}$ be lattice polytopes with $\dim P_i = n_i$ for $i = 1, 2$. Also let S_i be the set of vertices of P_i .

- Use supporting hyperplanes to prove that every element of $S_1 \times S_2$ is a vertex of $P_1 \times P_2$.
- Prove that $P_1 \times P_2 = \text{Conv}(S_1 \times S_2)$ and conclude that $S_1 \times S_2$ is the set of vertices of $P_1 \times P_2$.

2.4.5. The goal of this exercise is to prove Proposition 2.4.9. We know from Exercise 2.4.4 that the vertices of $P_1 \times P_2$ are the ordered pairs (v_1, v_2) where v_i is a vertex of P_i .

- Adapt the argument of part (a) of Theorem 2.4.7 to show that $C_{(v_1, v_2)} = C_{v_1} \times C_{v_2}$. Taking duals, we see that the maximal cones of $\Sigma_{P_1 \times P_2}$ are $\sigma_{(v_1, v_2)} = \sigma_{v_1} \times \sigma_{v_2}$.
- Given rational polyhedral cones $\sigma_i \subseteq (N_i)_{\mathbb{R}}$ and faces $\tau_i \subseteq \sigma_i$, prove that $\tau_1 \times \tau_2$ is a face of $\sigma_1 \times \sigma_2$ and that all faces of $\sigma_1 \times \sigma_2$ arise this way.
- Prove that $\Sigma_{P_1 \times P_2} = \Sigma_{P_1} \times \Sigma_{P_2}$.

2.4.6. Consider positive integers $1 = q_0 \leq q_2 \leq \dots \leq q_n$ with the property that $q_i \mid \sum_{j=0}^n q_j$ for $i = 0, \dots, n$. Set $k_i = (\sum_{j=0}^n q_j) / q_i$ for $i = 1, \dots, n$ and let

$$P_{q_0, \dots, q_n} = \text{Conv}(0, k_1 e_1, k_2 e_2, \dots, k_n e_n) - (1, \dots, 1).$$

Prove that P_{q_0, \dots, q_n} is reflexive and explain how it relates to Example 2.4.5. We will prove later that the toric variety of this polytope is the weighted projective space $\mathbb{P}(q_0, \dots, q_n)$.

2.4.7. The *Sylvester sequence* is defined by $a_0 = 2$ and $a_{k+1} = 1 + a_1 a_2 \cdots a_k$. It begins $2, 3, 7, 43, 1807, \dots$ and is described in [157, A000058]. Now fix a positive integer $n \geq 3$ and define q_0, \dots, q_n by $q_0 = q_1 = 1$ and $q_i = 2(a_{n-1} - 1)/a_{n-i}$ for $i = 2, \dots, n$. For $n = 3$ and 4 this gives $1, 1, 4, 6$ and $1, 1, 12, 28, 42$. Prove that q_0, \dots, q_n satisfies the conditions of Exercise 2.4.6 and hence gives a reflexive simplex, denoted $S_{Q'_n}$ in [132]. This paper proves that when $n \geq 4$, $S_{Q'_n}$ has the largest volume of all n -dimensional reflexive simplices and conjectures that it also has the largest number of lattice points.

Normal Toric Varieties

§3.0. Background: Abstract Varieties

The projective toric varieties studied in Chapter 2 are unions of Zariski open sets, each of which is an affine variety. We begin with a general construction of abstract varieties obtained by gluing together affine varieties in an analogous way. The resulting varieties will be *abstract* in the sense that they do not come with any given ambient affine or projective space. We will see that this is exactly the idea needed to construct a toric variety using the combinatorial data contained in a fan.

Sheaf theory, while important for later chapters, will make only a modest appearance here. For a more general approach to the concept of abstract variety, we recommend standard books such as [48], [77] or [152].

Regular Functions. Let $V = \text{Spec}(R)$ be an affine variety. In §1.0, we defined the Zariski open subset $V_f = V \setminus \mathbf{V}(f) \subseteq V$ for $f \in R$ and showed that $V_f = \text{Spec}(R_f)$, where R_f is the localization of R at f . The open sets V_f form a *basis* for the Zariski topology on V in the sense that every open set U is a (finite) union $U = \bigcup_{f \in S} V_f$ for some $S \subseteq R$ (Exercise 3.0.1).

For an affine variety, a morphism $V \rightarrow \mathbb{C}$ is called a *regular map*, so that the coordinate ring of V consists of all regular maps from V to \mathbb{C} . We now define what it means to be regular on an open subset of V .

Definition 3.0.1. Given an affine variety $V = \text{Spec}(R)$ and a Zariski open $U \subseteq V$, we say a function $\phi : U \rightarrow \mathbb{C}$ is **regular** if for all $p \in U$, there exists $f_p \in R$ such that $p \in V_{f_p} \subseteq U$ and $\phi|_{V_{f_p}} \in R_{f_p}$. Then define

$$\mathcal{O}_V(U) = \{\phi : U \rightarrow \mathbb{C} \mid \phi \text{ is regular}\}.$$

The condition $p \in V_{f_p}$ means that $f_p(p) \neq 0$, and saying $\phi|_{V_{f_p}} \in R_{f_p}$ means that $\phi = a_p/f_p^{n_p}$ for some $a_p \in R$ and $n_p \geq 0$.

Here are some cases where $\mathcal{O}_V(U)$ is easy to compute.

Proposition 3.0.2. *Let $V = \text{Spec}(R)$ be an affine variety.*

- (a) $\mathcal{O}_V(V) = R$.
- (b) If $f \in R$, then $\mathcal{O}_V(V_f) = R_f$.

Proof. It is clear from Definition 3.0.1 that elements of R define regular functions on V , hence elements of $\mathcal{O}_V(V)$. Conversely, if $\phi \in \mathcal{O}_V(V)$, then for all $p \in V$ there is $f_p \in R$ such that $p \in V_{f_p}$ and $\phi = a_p/f_p^{n_p} \in R_{f_p}$. The ideal $I = \langle f_p^{n_p} \mid p \in V \rangle \subseteq R$ satisfies $\mathbf{V}(I) = \emptyset$ since $f_p(p) \neq 0$ for all $p \in V$. Hence the Nullstellensatz implies that $\sqrt{I} = \mathbf{I}(\mathbf{V}(I)) = R$, so there exists a finite set $S \subseteq V$ and polynomials g_p for $p \in S$ such that

$$1 = \sum_{p \in S} g_p f_p^{n_p}.$$

Hence $\phi = \sum_{p \in S} g_p f_p^{n_p} \phi = \sum_{p \in S} g_p a_p \in R$, as desired.

For part (b), let $U \subseteq V_f$ be Zariski open. Then U is Zariski open in V , and whenever $g \in R$ satisfies $V_g \subseteq U$, we have $V_g = V_{fg}$ with coordinate ring

$$R_{fg} = (R_f)_{g/f^\ell}$$

for all $\ell \geq 0$. These observations easily imply that

$$(3.0.1) \quad \mathcal{O}_V(U) = \mathcal{O}_{V_f}(U).$$

Then setting $U = V_f$ gives

$$\mathcal{O}_V(V_f) = \mathcal{O}_{V_f}(V_f) = R_f,$$

where the last equality follows by applying part (a) to $V_f = \text{Spec}(R_f)$. □

Local Rings. When $V = \text{Spec}(R)$ is an irreducible affine variety, we can describe regular functions using the *local rings* $\mathcal{O}_{V,p}$ introduced in §1.0. A rational function in $\mathbb{C}(V)$ is contained in the local ring $\mathcal{O}_{V,p}$ precisely when it is regular in a neighborhood of p . It follows that whenever $U \subseteq V$ is open, we have

$$\bigcap_{p \in U} \mathcal{O}_{V,p} = \mathcal{O}_V(U).$$

Thus regular functions on U are rational functions on V that are defined everywhere on U . In particular, when $U = V$, Proposition 3.0.2 implies that

$$(3.0.2) \quad \bigcap_{p \in V} \mathcal{O}_{V,p} = \mathcal{O}_V(V) = R = \mathbb{C}[V].$$

The Structure Sheaf of an Affine Variety. Given an affine variety V , the operation

$$U \mapsto \mathcal{O}_V(U), \quad U \subseteq V \text{ open,}$$

has the following useful properties:

- When $W \subseteq U$, Definition 3.0.1 shows that there is an obvious restriction map

$$\rho_{U,W} : \mathcal{O}_V(U) \rightarrow \mathcal{O}_V(W)$$

defined by $\rho_{U,W}(\phi) = \phi|_W$. It follows that $\rho_{U,U}$ is the identity map and that $\rho_{V,W} \circ \rho_{U,V} = \rho_{U,W}$ whenever $W \subseteq V \subseteq U$.

- If $\{U_\alpha\}$ is an open cover of $U \subseteq V$, then the sequence

$$0 \longrightarrow \mathcal{O}_V(U) \longrightarrow \prod_{\alpha} \mathcal{O}_V(U_\alpha) \rightrightarrows \prod_{\alpha,\beta} \mathcal{O}_V(U_\alpha \cap U_\beta)$$

is exact. Here, the second arrow is defined by the restrictions ρ_{U,U_α} and the double arrow is defined by $\rho_{U_\alpha, U_\alpha \cap U_\beta}$ and $\rho_{U_\beta, U_\alpha \cap U_\beta}$. Exactness at $\mathcal{O}_V(U)$ means that regular functions are determined locally (that is, two regular functions on U are equal if their restrictions to all U_α are equal), and exactness at $\prod_{\alpha} \mathcal{O}_V(U_\alpha)$ means that regular functions on the U_α agreeing on the overlaps $U_\alpha \cap U_\beta$ patch together to give a regular function on U .

In the language of sheaf theory, these properties imply that \mathcal{O}_V is a *sheaf* of \mathbb{C} -algebras, called the *structure sheaf* of V . We call (V, \mathcal{O}_V) a *ringed space over \mathbb{C}* . Also, since (3.0.1) holds for all open sets $U \subseteq V_f$, we write

$$\mathcal{O}_V|_{V_f} = \mathcal{O}_{V_f}.$$

In terms of ringed spaces, this means $(V_f, \mathcal{O}_V|_{V_f}) = (V_f, \mathcal{O}_{V_f})$.

Morphisms. By §1.0, a polynomial mapping $\Phi : V_1 \rightarrow V_2$ between affine varieties corresponds to the \mathbb{C} -algebra homomorphism $\Phi^* : \mathbb{C}[V_2] \rightarrow \mathbb{C}[V_1]$ defined by $\Phi^*(g) = g \circ \Phi$ for $g \in \mathbb{C}[V_2]$. We now extend this to open sets of affine varieties.

Definition 3.0.3. Let $U_i \subseteq V_i$ be Zariski open subsets of affine varieties for $i = 1, 2$. A function $\Phi : U_1 \rightarrow U_2$ is a **morphism** if $\phi \mapsto \phi \circ \Phi$ defines a map

$$\Phi^* : \mathcal{O}_{V_2}(U_2) \longrightarrow \mathcal{O}_{V_1}(U_1).$$

Thus $\Phi : U_1 \rightarrow U_2$ is a morphism if composing Φ with regular functions on U_2 gives regular functions on U_1 . Note also that Φ^* is a \mathbb{C} -algebra homomorphism since it comes from composition of functions.

Example 3.0.4. Suppose that $\Phi : V_1 \rightarrow V_2$ is a morphism according to Definition 3.0.3. If $V_i = \text{Spec}(R_i)$, then the above map Φ^* gives the \mathbb{C} -algebra homomorphism

$$R_2 = \mathcal{O}_{V_2}(V_2) \longrightarrow \mathcal{O}_{V_1}(V_1) = R_1.$$

By Chapter 1, the \mathbb{C} -algebra homomorphism $R_2 \rightarrow R_1$ gives a map of affine varieties $V_2 \rightarrow V_1$. In Exercise 3.0.3 you will show that this is the original map $\Phi : V_1 \rightarrow V_2$ we started with. \diamond

Example 3.0.4 shows that when we apply Definition 3.0.3 to maps between affine varieties, we get the same morphisms as in Chapter 1. In Exercise 3.0.3 you will verify the following properties of morphisms:

- If U is open in an affine variety V , then

$$\mathcal{O}_V(U) = \{\phi : U \rightarrow \mathbb{C} \mid \phi \text{ is a morphism}\}.$$

Hence regular functions on U are just morphisms from U to \mathbb{C} .

- A composition of morphisms is a morphism.
- An inclusion of open sets $W \subseteq U$ of an affine variety V is a morphism.
- Morphisms are continuous in the Zariski topology.

We say that a morphism $\Phi : U_1 \rightarrow U_2$ is an *isomorphism* if Φ is bijective and its inverse function $\Phi^{-1} : U_2 \rightarrow U_1$ is also a morphism.

Gluing Together Affine Varieties. We now are ready to define abstract varieties by gluing together open subsets of affine varieties. The model is what happens for \mathbb{P}^n . Recall from §2.0 of that \mathbb{P}^n is covered by open sets

$$U_i = \mathbb{P}^n \setminus \mathbf{V}(x_i) = \text{Spec}\left(\mathbb{C}\left[\frac{x_0}{x_i}, \dots, \frac{x_{i-1}}{x_i}, \frac{x_{i+1}}{x_i}, \dots, \frac{x_n}{x_i}\right]\right)$$

for $i = 0, \dots, n$. Each U_i is a copy of \mathbb{C}^n that uses a different set of variables. For $i \neq j$, we “glue together” these copies as follows. We have open subsets

$$(3.0.3) \quad (U_i)_{\frac{x_j}{x_i}} \subseteq U_i \quad \text{and} \quad (U_j)_{\frac{x_i}{x_j}} \subseteq U_j,$$

and we also have the isomorphism

$$(3.0.4) \quad g_{ji} : (U_i)_{\frac{x_j}{x_i}} \xrightarrow{\sim} (U_j)_{\frac{x_i}{x_j}}$$

since both give the same open set $U_i \cap U_j$ in \mathbb{P}^n . The notation g_{ji} was chosen so that $g_{ji}(x)$ means $x \in U_i$ since the index i is closest to x , hence $g_{ji}(x) \in U_j$. At the level of coordinate rings, g_{ji} comes from the isomorphism

$$g_{ji}^* : \mathbb{C}\left[\frac{x_0}{x_j}, \dots, \frac{x_{j-1}}{x_j}, \frac{x_{j+1}}{x_j}, \dots, \frac{x_n}{x_j}\right]_{\frac{x_i}{x_j}} \simeq \mathbb{C}\left[\frac{x_0}{x_i}, \dots, \frac{x_{i-1}}{x_i}, \frac{x_{i+1}}{x_i}, \dots, \frac{x_n}{x_i}\right]_{\frac{x_j}{x_i}}$$

defined by

$$\frac{x_k}{x_j} \longmapsto \frac{x_k}{x_i} / \frac{x_j}{x_i} \quad (k \neq j) \quad \text{and} \quad \left(\frac{x_i}{x_j}\right)^{-1} \longmapsto \frac{x_j}{x_i}.$$

We can turn this around and start from the affine varieties $U_i \simeq \mathbb{C}^n$ given above and glue together the open sets in (3.0.3) using the isomorphisms g_{ji} from (3.0.4). This gluing is consistent since $g_{ij} = g_{ji}^{-1}$ and $g_{ki} = g_{kj} \circ g_{ji}$ wherever all three maps are defined. The result of this gluing is the projective space \mathbb{P}^n .

To generalize this, suppose we have a finite collection $\{V_\alpha\}_\alpha$ of affine varieties and for all pairs α, β we have Zariski open sets $V_{\beta\alpha} \subseteq V_\alpha$ and isomorphisms $g_{\beta\alpha} : V_{\beta\alpha} \simeq V_{\alpha\beta}$ satisfying the following compatibility conditions:

- $g_{\alpha\beta} = g_{\beta\alpha}^{-1}$ for all pairs α, β .
- $g_{\beta\alpha}(V_{\beta\alpha} \cap V_{\gamma\alpha}) = V_{\alpha\beta} \cap V_{\gamma\beta}$ and $g_{\gamma\alpha} = g_{\gamma\beta} \circ g_{\beta\alpha}$ on $V_{\beta\alpha} \cap V_{\gamma\alpha}$ for all α, β, γ .

The notation $g_{\beta\alpha}$ means that in the expression $g_{\beta\alpha}(x)$, the point x lies in V_α since α is the index closest to x , and the result $g_{\beta\alpha}(x)$ lies in V_β .

We are now ready to glue. Let Y be the disjoint union of the V_α and define a relation \sim on Y by $a \sim b$ if and only if $a \in V_\alpha$, $b \in V_\beta$ for some α, β with $b = g_{\beta\alpha}(a)$. The first compatibility condition shows that \sim is reflexive and symmetric; the second shows that it is transitive. Hence \sim is an equivalence relation and we can form the quotient space $X = Y / \sim$ with the quotient topology. For each α , let

$$U_\alpha = \{[a] \in X \mid a \in V_\alpha\}.$$

Then $U_\alpha \subseteq X$ is an open set and the map $h_\alpha(a) = [a]$ defines a homeomorphism $h_\alpha : V_\alpha \simeq U_\alpha \subseteq X$. Thus X locally looks like an affine variety.

Definition 3.0.5. We call X the *abstract variety* determined by the above data.

An abstract variety X comes equipped with the Zariski topology whose open sets are those sets that restrict to open sets in each U_α . The Zariski closed subsets $Y \subseteq X$ are called *subvarieties* of X . We say that X is *irreducible* if it is not the union of two proper subvarieties. One can show that X is a finite union of irreducible subvarieties $X = Y_1 \cup \cdots \cup Y_s$ such that $Y_i \not\subseteq Y_j$ for $i \neq j$. We call the Y_i the *irreducible components* of X .

Here are some examples of Definition 3.0.5.

Example 3.0.6. We saw above that \mathbb{P}^n can be obtained by gluing together the open sets (3.0.3) using the isomorphisms g_{ij} from (3.0.4). This shows that \mathbb{P}^n is an abstract variety with affine open subset $U_i \subseteq \mathbb{P}^n$. More generally, given a projective variety $V \subseteq \mathbb{P}^n$, we can cover V with affine open subset $V \cap U_i$, and the gluing implicit in equation (2.0.8). We conclude that projective varieties are also abstract varieties. \diamond

Example 3.0.7. In a similar way, $\mathbb{P}^n \times \mathbb{C}^m$ can be viewed as gluing affine spaces $U_i \times \mathbb{C}^m \simeq \mathbb{C}^{n+m}$ along suitable open subsets. Thus $\mathbb{P}^n \times \mathbb{C}^m$ is an abstract variety, and the same is true for subvarieties $V \subseteq \mathbb{P}^n \times \mathbb{C}^m$. \diamond

Example 3.0.8. Let $V_0 = \mathbb{C}^2 = \text{Spec}(\mathbb{C}[u, v])$ and $V_1 = \mathbb{C}^2 = \text{Spec}(\mathbb{C}[w, z])$, with

$$\begin{aligned} V_{10} &= V_0 \setminus \mathbf{V}(v) = \text{Spec}(\mathbb{C}[u, v]_v) \\ V_{01} &= V_1 \setminus \mathbf{V}(z) = \text{Spec}(\mathbb{C}[w, z]_z) \end{aligned}$$

and gluing data

$$\begin{aligned} g_{10} : V_{10} &\rightarrow V_{01} \text{ coming from the } \mathbb{C}\text{-algebra homomorphism} \\ g_{01}^* : \mathbb{C}[w, z]_z &\rightarrow \mathbb{C}[u, v]_v \text{ defined by } w \mapsto uv \text{ and } z \mapsto 1/v \end{aligned}$$

and

$$\begin{aligned} g_{01} : V_{01} &\rightarrow V_{01} \text{ coming from the } \mathbb{C}\text{-algebra homomorphism} \\ g_{01}^* : \mathbb{C}[u, v]_v &\rightarrow \mathbb{C}[w, z]_z \text{ defined by } u \mapsto wz \text{ and } v \mapsto 1/z. \end{aligned}$$

One checks that $g_{01} = g_{10}^{-1}$, and the other compatibility condition is satisfied since there are only two V_i . It follows that we get an abstract variety X .

The variety X has another description. Consider the product $\mathbb{P}^1 \times \mathbb{C}^2$ with homogeneous coordinates (x_0, x_1) on \mathbb{P}^1 and coordinates (x, y) on \mathbb{C}^2 . We will identify X with the subvariety $W = \mathbf{V}(x_0y - x_1x) \subseteq \mathbb{P}^1 \times \mathbb{C}^2$, called the *blowup of \mathbb{C}^2 at the origin*, and denoted $\text{Bl}_0(\mathbb{C}^2)$. First note that $\mathbb{P}^1 \times \mathbb{C}^2$ is covered by

$$U_0 \times \mathbb{C}^2 = \text{Spec}(\mathbb{C}[x_1/x_0, x, y]) \quad \text{and} \quad U_1 \times \mathbb{C}^2 = \text{Spec}(\mathbb{C}[x_0/x_1, x, y]).$$

Then W is covered by $W_0 = W \cap (U_0 \times \mathbb{C}^2)$ and $W_1 = W \cap (U_1 \times \mathbb{C}^2)$. Also,

$$W_0 = \mathbf{V}(y - (x_1/x_0)x) \subseteq U_0 \times \mathbb{C}^2,$$

which gives the coordinate ring

$$\mathbb{C}[x_1/x_0, x, y]/\langle y - (x_1/x_0)x \rangle \simeq \mathbb{C}[x, x_1/x_0] \quad \text{via } y \mapsto (x_1/x_0)x.$$

Similarly, $W_1 = \mathbf{V}(x - (x_0/x_1)y) \subseteq U_1 \times \mathbb{C}^2$ has coordinate ring

$$\mathbb{C}[x_0/x_1, x, y]/\langle x - (x_0/x_1)y \rangle \simeq \mathbb{C}[y, x_0/x_1] \quad \text{via } x \mapsto (x_0/x_1)y.$$

You can check that these are glued together in W in exactly the same way V_0 and V_1 are glued together in X . We will generalize this example in Exercise 3.0.8. \diamond

Morphisms Between Abstract Varieties. Let X and Y be abstract varieties with affine open covers $X = \bigcup_{\alpha} U_{\alpha}$ and $Y = \bigcup_{\beta} U'_{\beta}$. A *morphism* $\Phi : X \rightarrow Y$ is a Zariski continuous mapping such that the restrictions

$$\Phi|_{U_{\alpha} \cap \Phi^{-1}(U'_{\beta})} : U_{\alpha} \cap \Phi^{-1}(U'_{\beta}) \longrightarrow U'_{\beta}$$

are morphisms in the sense of Definition 3.0.3.

The Structure Sheaf of an Abstract Variety. Let U be an open subset of an abstract variety X and set $W_{\alpha} = h_{\alpha}^{-1}(U \cap U_{\alpha}) \subseteq V_{\alpha}$. Then a function $\phi : U \rightarrow \mathbb{C}$ is *regular* if

$$\phi \circ h_{\alpha}|_{W_{\alpha}} : W_{\alpha} \longrightarrow \mathbb{C}$$

is regular for all α . The compatibility conditions ensure that this is well-defined, so that one can define

$$\mathcal{O}_X(U) = \{\phi : U \rightarrow \mathbb{C} \mid \phi \text{ is regular}\}.$$

This gives the *structure sheaf* \mathcal{O}_X of X . Thus an abstract variety is really a ringed space (X, \mathcal{O}_X) with a finite open covering $\{U_\alpha\}_\alpha$ such that $(U_\alpha, \mathcal{O}_X|_{U_\alpha})$ is isomorphic to the ringed space $(V_\alpha, \mathcal{O}_{V_\alpha})$ of the affine variety V_α . (We leave the definition of isomorphism of ringed spaces to the reader.)

Open and Closed Subvarieties. Given an abstract variety X and an open subset U , we note that U has a natural structure of an abstract variety. For an affine open subset $U_\alpha \subseteq X$, $U \cap U_\alpha$ is open in U_α and hence can be written as a union $U \cap U_\alpha = \bigcup_{f \in S} (U_\alpha)_f$ for a finite subset $S \subseteq \mathbb{C}[U_\alpha]$. It follows that U is covered by finitely many affine open subsets and thus is an abstract variety. The structure sheaf \mathcal{O}_U is simply the restriction of \mathcal{O}_X to U , i.e., $\mathcal{O}_U = \mathcal{O}_X|_U$. Note also that a function $\phi : U \rightarrow \mathbb{C}$ is regular if and only if ϕ is a morphism as defined above.

In a similar way, a closed subset $Y \subseteq X$ also gives an abstract variety. For an affine open set $U \subseteq X$, $Y \cap U$ is closed in U and hence is an affine variety. Thus Y is covered by finitely many affine open subsets and thus is an abstract variety. This justifies the term “subvariety” for closed subsets of an abstract variety. The structure sheaf \mathcal{O}_Y is related to \mathcal{O}_X as follows. The inclusion $i : Y \hookrightarrow X$ is a morphism. Let $i_*\mathcal{O}_Y$ be the sheaf on X defined by $i_*\mathcal{O}_Y(U) = \mathcal{O}_Y(U \cap Y)$. Restricting functions on X to functions on Y gives a map of sheaves $\mathcal{O}_X \rightarrow i_*\mathcal{O}_Y$ whose kernel is the subsheaf $\mathcal{I}_Y \subseteq \mathcal{O}_X$ of functions vanishing on Y , meaning

$$\mathcal{I}_Y(U) = \{f \in \mathcal{O}_X(U) \mid f(p) = 0 \text{ for all } p \in Y \cap U\}.$$

In the language of Chapter 6, we have an exact sequence of sheaves

$$0 \longrightarrow \mathcal{I}_Y \longrightarrow \mathcal{O}_X \longrightarrow i_*\mathcal{O}_Y \longrightarrow 0.$$

All of the types of “variety” introduced so far can be subsumed under the concept of “abstract variety.” From now on, we will usually be thinking of abstract varieties. Hence we will usually say “variety” rather than “abstract variety.”

Local Rings and Rational Functions. Let p be a point of an affine variety V . Elements of the local ring $\mathcal{O}_{V,p}$ are quotients f/g in a suitable localization with $f, g \in \mathbb{C}[V]$ and $g(p) \neq 0$. It follows that V_g is a neighborhood of p in V and f/g is a regular function on V_g . In this way, we can think of elements of $\mathcal{O}_{V,p}$ as regular functions defined in a neighborhood of p .

This idea extends to the abstract case. Given a point p of an variety X and neighborhoods U_1, U_2 of p , regular functions $f_i : U_i \rightarrow \mathbb{C}$ are *equivalent at p* , written $f_1 \sim f_2$, if there is a neighborhood $p \in U \subseteq U_1 \cap U_2$ such that $f_1|_U = f_2|_U$.

Definition 3.0.9. Let p be a point of a variety X . Then

$$\mathcal{O}_{X,p} = \{f : U \rightarrow \mathbb{C} \mid U \text{ is a neighborhood of } p \text{ in } X\} / \sim$$

is the *local ring of X at p* .

Every $\phi \in \mathcal{O}_{X,p}$ has a well-defined value $\phi(p)$. It is not difficult to see that $\mathcal{O}_{X,p}$ is a local ring with unique maximal ideal

$$\mathfrak{m}_{X,p} = \{\phi \in \mathcal{O}_{X,p} \mid \phi(p) = 0\}.$$

The local ring $\mathcal{O}_{X,p}$ can also be defined as the direct limit

$$\mathcal{O}_{X,p} = \varinjlim_{p \in U} \mathcal{O}_X(U)$$

over all neighborhoods of p in X (see Definition 6.0.1).

When X is irreducible, we can also define the field of rational functions $\mathbb{C}(X)$. A *rational function* on X is a regular function $f : U \rightarrow \mathbb{C}$ defined on a nonempty Zariski open set $U \subseteq X$, and two rational functions on X are *equivalent* if they agree on a nonempty Zariski open subset. In Exercise 3.0.4 you will show that this relation is an equivalence relation and that the set of equivalence classes is a field, called the *function field* of X , denoted $\mathbb{C}(X)$.

Normal Varieties. We return to the notion of normality introduced in Chapter 1.

Definition 3.0.10. An variety X is called **normal** if it is irreducible and the local rings $\mathcal{O}_{X,p}$ are normal for all $p \in X$.

At first glance, this looks different from the definition given for affine varieties in Definition 1.0.3. In fact, the two notions are equivalent in the affine case.

Proposition 3.0.11. *Let V be an irreducible affine variety. Then $\mathbb{C}[V]$ is normal if and only if the local rings $\mathcal{O}_{V,p}$ are normal for all $p \in V$.*

Proof. If $\mathcal{O}_{V,p}$ is normal for all p , then (3.0.2) shows that $\mathbb{C}[V]$ is an intersection of normal domains, all of which have the same field of fractions. Since such an intersection is normal by Exercise 1.0.7, it follows that $\mathbb{C}[V]$ is normal.

For the converse, suppose that $\mathbb{C}[V]$ is normal and let $\alpha \in \mathbb{C}(V)$ satisfy

$$\alpha^k + a_1\alpha^{k-1} + \cdots + a_k = 0, \quad a_i \in \mathcal{O}_{V,p}.$$

Write $a_i = g_i/f_i$ with $g_i, f_i \in \mathbb{C}[V]$ and $f_i(p) \neq 0$. The product $f = f_1 \cdots f_k$ has the properties that $a_i \in \mathbb{C}[V]_f$ and $f(p) \neq 0$. The localization $\mathbb{C}[V]_f$ is normal by Exercise 1.0.7 and is contained in $\mathcal{O}_{V,p}$ since $f(p) \neq 0$. Hence $\alpha \in \mathbb{C}[V]_f \subseteq \mathcal{O}_{V,p}$. This completes the proof. \square

Here is a consequence of Proposition 3.0.11 and Definition 3.0.10.

Proposition 3.0.12. *Let X be an irreducible variety with a cover consisting of affine open sets V_α . Then X is normal if and only if each V_α is normal.* \square

Smooth Varieties. For an affine variety V , the definition of a *smooth point* $p \in V$ (Definition 1.0.7) used $T_p(V)$, the Zariski tangent space of V at p , and $\dim_p V$, the maximum dimension of an irreducible component of V containing p . You will show in Exercise 3.0.2 that $T_p(X)$ and $\dim_p X$ are well-defined for a point $p \in X$ of a general variety.

Definition 3.0.13. Let X be a variety. A point $p \in X$ is *smooth* if $\dim T_p(X) = \dim_p X$, and X is *smooth* if every point of X is smooth.

Products of Varieties. As another example of abstract varieties and gluing, we indicate why the product $X_1 \times X_2$ of varieties X_1 and X_2 also has the structure of a variety. In §1.0 we constructed the product of affine varieties. From here, it is relatively routine to see that if X_1 is obtained by gluing together affine varieties U_α and X_2 is obtained by gluing together affines U'_β , then $X_1 \times X_2$ is obtained by gluing together the $U_\alpha \times U'_\beta$ in the corresponding fashion. Furthermore, $X_1 \times X_2$ has the correct universal mapping property. Namely, given a diagram

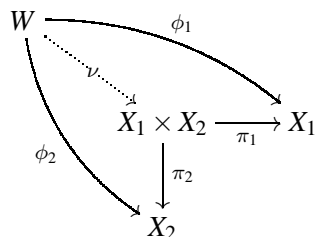

where $\phi_i : W \rightarrow X_i$ are morphisms, there is a unique morphism $\nu : W \rightarrow X_1 \times X_2$ (the dotted arrow) that makes the diagram commute.

Example 3.0.14. Let us construct the product $\mathbb{P}^1 \times \mathbb{C}^2$. Write $\mathbb{P}^1 = V_0 \cup V_1$ where $V_0 = \text{Spec}(\mathbb{C}[u])$ and $V_1 = \text{Spec}(\mathbb{C}[v])$, with the gluing given by

$$\mathbb{C}[v]_v \simeq \mathbb{C}[u]_u, \quad v \mapsto 1/u.$$

Then $\mathbb{P}^1 \times \mathbb{C}^2$ is constructed from

$$U_0 \times \mathbb{C}^2 = \text{Spec}(\mathbb{C}[u] \otimes_{\mathbb{C}} \mathbb{C}[x, y]) \simeq \mathbb{C}^3$$

$$U_1 \times \mathbb{C}^2 = \text{Spec}(\mathbb{C}[v] \otimes_{\mathbb{C}} \mathbb{C}[x, y]) \simeq \mathbb{C}^3,$$

with gluing given by

$$(U_0 \times \mathbb{C}^2)_u \simeq (U_1 \times \mathbb{C}^2)_v$$

corresponding to the obvious isomorphism of coordinate rings. ◇

Separated Varieties. From the point of view of the classical topology, arbitrary gluings can lead to varieties with some strange properties.

Example 3.0.15. In Example 3.0.14 we saw how to construct \mathbb{P}^1 from affine varieties $V_0 = \text{Spec}(\mathbb{C}[u]) \simeq \mathbb{C}$ and $V_1 = \text{Spec}(\mathbb{C}[v]) \simeq \mathbb{C}$ with the gluing given by $v \mapsto 1/u$ on open sets $\mathbb{C}^* \simeq (V_0)_u \subseteq V_0$ and $\mathbb{C}^* \simeq (V_1)_v \subseteq V_1$. This expresses \mathbb{P}^1 as

consisting of \mathbb{C}^* plus two additional points. But now consider the abstract variety arising from the gluing map

$$(V_0)_u \longrightarrow (V_1)_v$$

that corresponds to the map of \mathbb{C} -algebras defined by $v \mapsto u$. As before, the glued variety X consists of \mathbb{C}^* together with two additional points. However here we have a morphism $\pi : X \rightarrow \mathbb{C}$ whose fiber $\pi^{-1}(a)$ over $a \in \mathbb{C}^*$ contains one point, but whose fiber over 0 consists of two points, p_1 corresponding to $0 \in V_0$ and p_2 corresponding to $0 \in V_1$. If U_1, U_2 are classical open sets in X with $p_1 \in U_1$ and $p_2 \in U_2$, then $U_1 \cap U_2 \neq \emptyset$. So the *classical* topology on X is not Hausdorff. \diamond

Since varieties are rarely Hausdorff in the Zariski topology (Exercise 3.0.5), we need a different way to think about Example 3.0.15. Consider the product $X \times X$ and the *diagonal mapping* $\Delta : X \rightarrow X \times X$ defined by $\Delta(p) = (p, p)$ for $p \in X$. For X from Example 3.0.15, there is a morphism $X \times X \rightarrow \mathbb{C}$ whose fiber over 0 consists of the four points (p_i, p_j) . Any Zariski closed subset of $X \times X$ containing one of these four points must contain all of them. The image of the diagonal mapping contains (p_1, p_1) and (p_2, p_2) , but not the other two, so the diagonal is not Zariski closed. This example motivates the following definition.

Definition 3.0.16. We say a variety X is *separated* if the image of the diagonal map $\Delta : X \rightarrow X \times X$ is Zariski closed in $X \times X$.

For instance, \mathbb{C}^n is separated because the image of the diagonal in $\mathbb{C}^n \times \mathbb{C}^n = \text{Spec}(\mathbb{C}[x_1, \dots, x_n, y_1, \dots, y_n])$ is the affine variety $\mathbf{V}(x_1 - y_1, \dots, x_n - y_n)$. Similarly, any affine variety is separated.

The connection between failure of separatedness and failure of the Hausdorff property in the classical topology seen in Example 3.0.15 is a general phenomenon.

Theorem 3.0.17. *A variety is separated if and only if it is Hausdorff in the classical topology.* \square

Here are some additional properties of separated varieties (Exercise 3.0.6).

Proposition 3.0.18. *Let X be a separated variety.*

- (a) *If $f, g : Y \rightarrow X$ are morphisms, then $\{y \in Y \mid f(y) = g(y)\}$ is Zariski closed in Y .*
- (b) *If U, V are affine open subsets of X , then $U \cap V$ is also affine.* \square

The requirement that X be separated is often included in the *definition* of an abstract variety. When this is done, what we have called a variety is sometimes called a *pre-variety*.

Fiber Products. Finally in this section, we will discuss fiber products of varieties, a construction required for the discussion of proper morphisms in §3.4. First, if we

have mappings of sets $f : X \rightarrow S$ and $g : Y \rightarrow S$, then the *fiber product* $X \times_S Y$ is defined to be

$$(3.0.5) \quad X \times_S Y = \{(x, y) \in X \times Y \mid f(x) = g(y)\}.$$

The fiber product construction gives a very flexible language for describing ordinary products, intersections of subsets, fibers of mappings, the set where two mappings agree, and so forth:

- If S is a point, then $X \times_S Y$ is the ordinary product $X \times Y$.
- If X, Y are subsets of S and f, g are the inclusions, then $X \times_S Y \simeq X \cap Y$.
- If $Y = \{s\} \subseteq S$, then $X \times_S Y \simeq f^{-1}(\{s\})$.

The third property is the reason for the name. All are easy exercises that we leave to the reader.

In analogy with the universal mapping property of the product discussed above, the fiber product has the following universal property. Whenever we have mappings $\phi_1 : W \rightarrow X$ and $\phi_2 : W \rightarrow Y$ such that $f \circ \phi_1 = g \circ \phi_2$, there is a unique $\nu : W \rightarrow X \times_S Y$ that makes the following diagram commute.

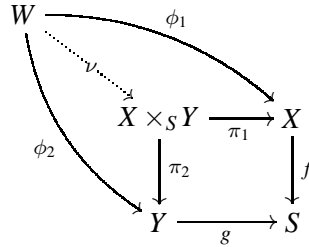

Equation (3.0.5) defines $X \times_S Y$ as a set. To prove that $X \times_S Y$ is a variety, we assume for simplicity that S is separated. Then $f : X \rightarrow S$ and $g : Y \rightarrow S$ give a morphism $(f, g) : X \times Y \rightarrow S \times S$, and one easily checks that

$$X \times_S Y = (f, g)^{-1}(\Delta(S)),$$

where $\Delta(S) \subseteq S \times S$ is the diagonal. This is closed in $S \times S$ since S is separated, and it follows that $X \times_S Y$ is closed in $X \times Y$ and hence has a natural structure as a variety. From here, it is straightforward to show that $X \times_S Y$ has the desired universal mapping property. Proving that $X \times_S Y$ is a variety when S is not separated takes more work and will not be discussed here.

In the affine case, we can also describe the coordinate ring of $X \times_S Y$. Let $X = \text{Spec}(R_1)$, $Y = \text{Spec}(R_2)$, and $S = \text{Spec}(R)$. The morphisms f, g correspond to ring homomorphisms $f^* : R \rightarrow R_1$, $g^* : R \rightarrow R_2$. Hence both R_1, R_2 have the structure of R -modules, and we have the tensor product $R_1 \otimes_R R_2$. This is also a finitely generated \mathbb{C} -algebra, though it may have nilpotents (Exercise 3.0.9). To get a coordinate ring, we need to take the quotient by the ideal N of all nilpotents.

Then one can prove that

$$X \times_S Y = \text{Spec}(R_1 \otimes_R R_2/N).$$

We can avoid worrying about nilpotents by constructing $X \times_S Y$ as the *affine scheme* $\text{Spec}(R_1 \otimes_R R_2)$. Interested readers can learn about the construction of fiber products as schemes in [48, I.3.1] and [77, pp. 87–89].

Exercises for §3.0.

3.0.1. Let $V = \text{Spec}(R)$ be an affine variety.

- Show that every ideal $I \subseteq R$ can be written in the form $I = \langle f_1, \dots, f_s \rangle$, where $f_i \in R$. (This is the Hilbert Basis Theorem in R .)
- Let $W \subseteq V$ be a subvariety. Show that the complement of W in V can be written as a union of a finite collection of open affine sets of the form V_f .
- Deduce that every open cover of V (in the Zariski topology) has a finite subcover. (This says that affine varieties are *quasicompact* in the Zariski topology.)

3.0.2. As in the affine case, we want to say a variety X is smooth at p if $\dim T_p(X) = \dim_p X$. In this exercise, you will show that this is a well-defined notion.

- Show that if $p \in X$ is in the intersection of two affine open sets $V_\alpha \cap V_\beta$, then the Zariski tangent spaces $T_{V_\alpha, p}$ and $T_{V_\beta, p}$ are isomorphic as vector spaces over \mathbb{C} .
- Show that $\dim_p X$ is a well-defined integer.
- Deduce that the proposed notion of smoothness at p is well-defined.

3.0.3. This exercise explores some properties of the morphisms defined in Definition 3.0.3.

- Prove the claim made in Example 3.0.4. Hint: Take a point $p \in V_1$ and define $\mathfrak{m}_p = \{f \in R_1 \mid f(p) = 0\}$. Then describe $(\Phi^*)^{-1}(\mathfrak{m}_p)$ in terms of $\Phi(p)$.
- Prove the properties of morphisms listed on page 96.

3.0.4. Let X be an irreducible abstract variety.

- Let f, g be rational functions on X . Show that $f \sim g$ if $f|_U = g|_U$ for some nonempty open set $U \subseteq X$ is an equivalence relation.
- Show that the set of equivalence classes of the relation in part (a) is a field.
- Show that if $U \subseteq X$ is a nonempty open subset of X , then $\mathbb{C}(U) \simeq \mathbb{C}(X)$.

3.0.5. Show that a variety is Hausdorff in the Zariski topology if and only if it consists of finitely many points.

3.0.6. Consider Proposition 3.0.18.

- Prove part (a) of the proposition. Hint: Show first that if $F : Y \rightarrow X \times X$ is defined by $F(y) = (f(y), g(y))$, then $Z = F^{-1}(\Delta(X))$.
- Prove part (b) of the proposition. Hint: Show first that $U \cap V$ can be identified with $\Delta(X) \cap (U \times V) \subseteq X \times X$.

3.0.7. Let $V = \text{Spec}(R)$ be an affine variety. The diagonal mapping $\Delta : V \rightarrow V \times V$ corresponds to a \mathbb{C} -algebra homomorphism $R \otimes_{\mathbb{C}} R \rightarrow R$. Which one? Hint: Consider the universal mapping property of $V \times V$.

3.0.8. In this exercise, we will study an important variety in $\mathbb{P}^{n-1} \times \mathbb{C}^n$, the *blowup* of \mathbb{C}^n at the origin, denoted $\text{Bl}_0(\mathbb{C}^n)$. This generalizes $\text{Bl}_0(\mathbb{C}^2)$ from Example 3.0.8. Write the homogeneous coordinates on \mathbb{P}^{n-1} as x_0, \dots, x_{n-1} , and the affine coordinates on \mathbb{C}^n as y_1, \dots, y_n . Let

$$(3.0.6) \quad W = \text{Bl}_0(\mathbb{C}^n) = \mathbf{V}(x_{i-1}y_j - x_{j-1}y_i \mid 1 \leq i < j \leq n) \subseteq \mathbb{P}^{n-1} \times \mathbb{C}^n.$$

Let U_{i-1} , $i = 1, \dots, n$, be the standard affine opens in \mathbb{P}^{n-1} :

$$U_{i-1} = \mathbb{P}^{n-1} \setminus \mathbf{V}(x_{i-1}),$$

$i = 1, \dots, n$ (note the slightly non-standard indexing). So the $U_{i-1} \times \mathbb{C}^n$ form a cover of $\mathbb{P}^{n-1} \times \mathbb{C}^n$.

(a) Show that for each $i = 1, \dots, n$, $W_{i-1} = W \cap (U_{i-1} \times \mathbb{C}^n) \simeq$

$$\text{Spec} \left(\mathbb{C} \left[\frac{x_0}{x_{i-1}}, \dots, \frac{x_{i-2}}{x_{i-1}}, \frac{x_i}{x_{i-1}}, \dots, \frac{x_{n-1}}{x_{i-1}}, y_i \right] \right)$$

using the equations (3.0.6) defining W .

(b) Give the gluing data for identifying the subsets $W_{i-1} \setminus \mathbf{V}(x_{j-1})$ and $W_{j-1} \setminus \mathbf{V}(x_{i-1})$.

3.0.9. Let $V = \mathbf{V}(y^2 - x) \subseteq \mathbb{C}^2$ and consider the morphism $\pi : V \rightarrow \mathbb{C}$ given by projection onto the x -axis. We will study the fibers of π .

(a) As noted in the text, the fiber $\pi^{-1}(0) = \{(0, 0)\}$ can be represented as the fiber product $\{0\} \times_{\mathbb{C}} V$. In terms of coordinate rings, we have $\{0\} = \text{Spec}(\mathbb{C}[x]/\langle x \rangle)$, $\mathbb{C} = \text{Spec}(\mathbb{C}[x])$ and $V = \text{Spec}(\mathbb{C}[x, y]/\langle y^2 - x \rangle)$. Prove that

$$\mathbb{C}[x]/\langle x \rangle \otimes_{\mathbb{C}[x]} \mathbb{C}[x, y]/\langle y^2 - x \rangle \simeq \mathbb{C}[y]/\langle y^2 \rangle.$$

Thus, the coordinate rings $\mathbb{C}[x]/\langle x \rangle$, $\mathbb{C}[x]$ and $\mathbb{C}[x, y]/\langle y^2 - x \rangle$ lead to a tensor product that has nilpotents and hence cannot be a coordinate ring.

(b) If $a \neq 0$ in \mathbb{C} , then $\pi^{-1}(a) = \{(a, \pm\sqrt{a})\}$. Show that the analogous tensor product is

$$\begin{aligned} \mathbb{C}[x]/\langle x - a \rangle \otimes_{\mathbb{C}[x]} \mathbb{C}[x, y]/\langle y^2 - x \rangle &\simeq \mathbb{C}[y]/\langle y^2 - a \rangle \\ &\simeq \mathbb{C}[y]/\langle y - \sqrt{a} \rangle \oplus \mathbb{C}[y]/\langle y + \sqrt{a} \rangle. \end{aligned}$$

This has no nilpotents and hence is the coordinate ring of $\pi^{-1}(a)$.

What happens in part (a) is that the two square roots coincide, so that we get only one point with “multiplicity 2.” The multiplicity information is recorded in the affine scheme $\text{Spec}(\mathbb{C}[y]/\langle y^2 \rangle)$. This is an example of the power of schemes.

§3.1. Fans and Normal Toric Varieties

In this section we construct the toric variety X_{Σ} corresponding to a fan Σ . We will also relate the varieties X_{Σ} to many of the examples encountered previously, and we will see how properties of the fan correspond to properties such as smoothness and compactness of X_{Σ} .

The Toric Variety of a Fan. A toric variety continues to mean the same thing as in Chapters 1 and 2, although we now allow abstract varieties as in §3.0.

Definition 3.1.1. A *toric variety* is an irreducible variety X containing a torus $T_N \simeq (\mathbb{C}^*)^n$ as a Zariski open subset such that the action of T_N on itself extends to an algebraic action of T_N on X . (By algebraic action, we mean an action $T_N \times X \rightarrow X$ given by a morphism.)

The other ingredient in this section is a fan in the vector space $N_{\mathbb{R}}$.

Definition 3.1.2. A *fan* Σ in $N_{\mathbb{R}}$ is a finite collection of cones σ such that:

- (a) Every $\sigma \in \Sigma$ is a strongly convex rational polyhedral cone.
- (b) For all $\sigma \in \Sigma$, each face of σ is also in Σ .
- (c) For all $\sigma_1, \sigma_2 \in \Sigma$, the intersection $\sigma_1 \cap \sigma_2$ is a face of each (hence also in Σ).

Furthermore, if Σ is a fan, then:

- The *support* of Σ is $|\Sigma| = \bigcup_{\sigma \in \Sigma} \sigma \subseteq N_{\mathbb{R}}$.
- $\Sigma(r)$ is the set of r -dimensional cones of Σ .

We have already seen some examples of fans. Theorem 2.3.2 shows that the normal fan Σ_P of a full dimensional lattice polytope $P \subseteq M_{\mathbb{R}}$ is a fan in the sense of Definition 3.1.2. However, there exist fans that are not equal to the normal fan of any lattice polytope. An example of such a fan will be given in Example 4.2.13.

We now show how the cones in any fan give the combinatorial data necessary to glue a collection of affine toric varieties together to yield an abstract toric variety. By Theorem 1.2.18, each cone σ in Σ gives the affine toric variety

$$U_{\sigma} = \text{Spec}(\mathbb{C}[S_{\sigma}]) = \text{Spec}(\mathbb{C}[\sigma^{\vee} \cap M]).$$

Recall from Definition 1.2.5 that a face $\tau \preceq \sigma$ is given by $\tau = \sigma \cap H_m$, where $m \in \sigma^{\vee}$ and $H_m = \{u \in N_{\mathbb{R}} \mid \langle m, u \rangle = 0\}$ is the hyperplane defined by m . In Chapter 1, we proved two useful facts:

First, Proposition 1.3.16 used the equality

$$(3.1.1) \quad S_{\tau} = S_{\sigma} + \mathbb{Z}(-m)$$

to show that $\mathbb{C}[S_{\tau}]$ is the localization $\mathbb{C}[S_{\sigma}]_{\chi^m}$. Thus $U_{\tau} = (U_{\sigma})_{\chi^m}$ when $\tau \preceq \sigma$.

Second, if $\tau = \sigma_1 \cap \sigma_2$, then Lemma 1.2.13 implies that

$$(3.1.2) \quad \sigma_1 \cap H_m = \tau = \sigma_2 \cap H_m,$$

for some $m \in \sigma_1^{\vee} \cap (-\sigma_2)^{\vee} \cap M$. This shows that

$$(3.1.3) \quad U_{\sigma_1} \supseteq (U_{\sigma_1})_{\chi^m} = U_{\tau} = (U_{\sigma_2})_{\chi^{-m}} \subseteq U_{\sigma_2}.$$

The following proposition gives an additional property of the S_{σ} and their semigroup rings that we will need.

Proposition 3.1.3. *If $\sigma_1, \sigma_2 \in \Sigma$ and $\tau = \sigma_1 \cap \sigma_2$, then*

$$S_\tau = S_{\sigma_1} + S_{\sigma_2}.$$

Proof. The inclusion $S_{\sigma_1} + S_{\sigma_2} \subseteq S_\tau$ follows directly from the general fact that $\sigma_1^\vee + \sigma_2^\vee = (\sigma_1 \cap \sigma_2)^\vee = \tau^\vee$. For the reverse inclusion, take $p \in S_\tau$ and assume that $m \in \sigma_1^\vee \cap (-\sigma_2)^\vee \cap M$ satisfies (3.1.2). Then (3.1.1) applied to σ_1 gives $p = q + \ell(-m)$ for some $q \in S_{\sigma_1}$ and $\ell \in \mathbb{Z}_{\geq 0}$. But $-m \in \sigma_2^\vee$ implies $-m \in S_{\sigma_2}$, so that $p \in S_{\sigma_1} + S_{\sigma_2}$. \square

This result is sometimes called the *Separation Lemma* and is a key ingredient in showing that the toric varieties X_Σ are separated in the sense of Definition 3.0.16.

Example 3.1.4. Let $\sigma_1 = \text{Cone}(e_1 + e_2, e_2)$ (as in Exercise 1.2.11), and let $\sigma_2 = \text{Cone}(e_1, e_1 + e_2)$ in $N_{\mathbb{R}} = \mathbb{R}^2$. Then $\tau = \sigma_1 \cap \sigma_2 = \text{Cone}(e_1 + e_2)$. We show the dual cones $\sigma_1^\vee = \text{Cone}(e_1, -e_1 + e_2)$, $\sigma_2^\vee = \text{Cone}(e_1 - e_2, e_2)$, and $\tau^\vee = \sigma_1^\vee + \sigma_2^\vee$ in Figure 1.

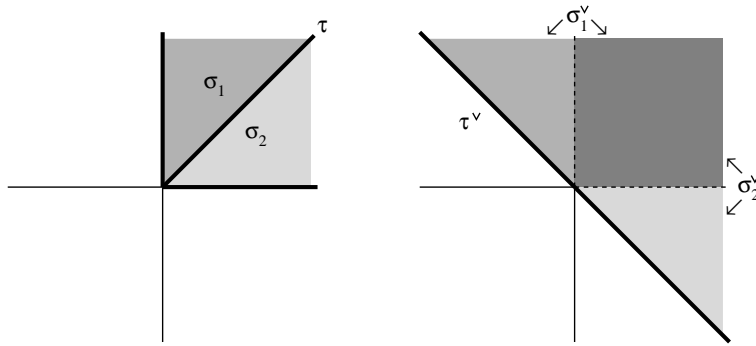

Figure 1. The cones σ_1, σ_2, τ and their duals

The dark shaded region on the right is $\sigma_1^\vee \cap \sigma_2^\vee$. Note $\tau = \sigma_1 \cap H_m = \sigma_2 \cap H_{-m}$, where $m = -e_1 + e_2 \in \sigma_1^\vee$ and $-m = e_1 - e_2 \in \sigma_2^\vee$. Since S_τ is the set of all sums $m + m'$ with $m \in \sigma_1^\vee \cap M$ and $m' \in \sigma_2^\vee \cap M$, we see that $S_\tau = S_{\sigma_1} + S_{\sigma_2}$. \diamond

Now consider the collection of affine toric varieties $U_\sigma = \text{Spec}(\mathbb{C}[S_\sigma])$, where σ runs over all cones in a fan Σ . Let σ_1 and σ_2 be any two of these cones and let $\tau = \sigma_1 \cap \sigma_2$. By (3.1.3), we have an isomorphism

$$g_{\sigma_2, \sigma_1} : (U_{\sigma_1})_{\chi^m} \simeq (U_{\sigma_2})_{\chi^{-m}}$$

which is the identity on U_τ . By Exercise 3.1.1, the compatibility conditions as in §3.0 for gluing the affine varieties U_σ along the subvarieties $(U_\sigma)_{\chi^m}$ are satisfied. Hence we obtain an abstract variety X_Σ associated to the fan Σ .

Theorem 3.1.5. *Let Σ be a fan in $N_{\mathbb{R}}$. The variety X_Σ is a normal separated toric variety.*

Proof. Since each cone in Σ is strongly convex, $\{0\} \subseteq N$ is a face of all $\sigma \in \Sigma$. Hence we have $T_N = \text{Spec}(\mathbb{C}[M]) \simeq (\mathbb{C}^*)^n \subseteq U_\sigma$ for all σ . These tori are all identified by the gluing, so we have $T_N \subseteq X_\Sigma$. We know from Chapter 1 that each U_σ has an action of T_N . The gluing isomorphism g_{σ_2, σ_1} reduces to the identity mapping on $\mathbb{C}[S_{\sigma_1 \cap \sigma_2}]$. Hence the actions are compatible on the intersections of every pair of sets in the open affine cover, and patch together to give an algebraic action of T_N on X_Σ .

The variety X_Σ is irreducible because all of the U_σ are irreducible affine toric varieties containing the torus T_N . Furthermore, U_σ is a normal affine variety by Theorem 1.3.5. Hence the variety X_Σ is normal by Proposition 3.0.12.

To see that X_Σ is separated it suffices to show that for each pair of cones σ_1, σ_2 in Σ , the image of the diagonal map

$$\Delta : U_\tau \rightarrow U_{\sigma_1} \times U_{\sigma_2}, \quad \tau = \sigma_1 \cap \sigma_2$$

is Zariski closed (Exercise 3.1.2). But Δ comes from the \mathbb{C} -algebra homomorphism

$$\Delta^* : \mathbb{C}[S_{\sigma_1}] \otimes_{\mathbb{C}} \mathbb{C}[S_{\sigma_2}] \longrightarrow \mathbb{C}[S_\tau]$$

defined by $\chi^m \otimes \chi^n \mapsto \chi^{m+n}$. By Proposition 3.1.3, Δ^* is surjective, so that

$$\mathbb{C}[S_\tau] \simeq (\mathbb{C}[S_{\sigma_1}] \otimes_{\mathbb{C}} \mathbb{C}[S_{\sigma_2}]) / \ker(\Delta^*).$$

Hence the image of Δ is a Zariski closed subset of $U_{\sigma_1} \times U_{\sigma_2}$. \square

Toric varieties were originally known as *torus embeddings*, and the variety X_Σ would be written $T_N \text{emb}(\Sigma)$ in older references such as [134]. Other commonly used notations are $X(\Sigma)$, or $X(\Delta)$, if the fan is denoted by Δ . When we want to emphasize the dependence on the lattice N , we will write X_Σ as $X_{\Sigma, N}$.

Many of the toric varieties encountered in Chapters 1 and 2 come from fans. For example, Theorem 1.3.5 implies that a normal affine toric variety comes from a fan consisting of a single cone σ together with all of its faces. Furthermore, the projective toric variety associated to a lattice polytope in Chapter 2 comes from a fan. Here is the precise result.

Proposition 3.1.6. *Let $P \subseteq M_{\mathbb{R}}$ be a full dimensional lattice polytope. Then the projective toric variety $X_P \simeq X_{\Sigma_P}$, where Σ_P is the normal fan of P .*

Proof. When P is very ample, this follows immediately from the description of the intersections of the affine open pieces of X_P in Proposition 2.3.12 and the definition of the normal fan Σ_P . The general case follows since the normal fans of P and kP are the same for all positive integers k . \square

In general, every separated normal toric varieties comes from a fan. This is a consequence of a theorem of Sumihiro from [167].

Theorem 3.1.7 (Sumihiro). *Let the torus T_N act on a normal separated variety X . Then every point $p \in X$ has a T_N -invariant affine open neighborhood.* \square

Corollary 3.1.8. *Let X be a normal separated toric variety with torus T_N . Then there exists a fan Σ in $N_{\mathbb{R}}$ such that $X \simeq X_{\Sigma}$.*

Proof. The proof will be sketched in Exercise 3.2.11 after we have developed the properties of T_N -orbits on toric varieties. \square

Examples. We now turn to some concrete examples. Many of these are toric varieties already encountered in previous chapters.

Example 3.1.9. Consider the fan Σ in $N_{\mathbb{R}} = \mathbb{R}^2$ in Figure 2, where $N = \mathbb{Z}^2$ has standard basis e_1, e_2 . This is the normal fan of the simplex Δ_2 as in Example 2.3.8. Here we show all points in the cones inside a rectangular viewing box (all figures of fans in the plane in this chapter will be drawn using the same convention.)

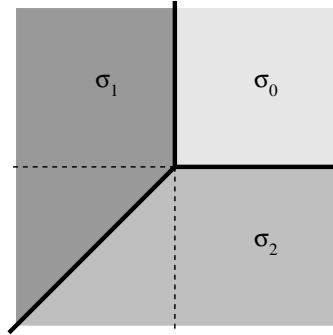

Figure 2. The fan Σ for \mathbb{P}^2

From the discussion in Chapter 2, we expect $X_{\Sigma} \simeq \mathbb{P}^2$, and we will show this in detail. The fan Σ has three 2-dimensional cones $\sigma_0 = \text{Cone}(e_1, e_2)$, $\sigma_1 = \text{Cone}(-e_1 - e_2, e_2)$, and $\sigma_2 = \text{Cone}(e_1, -e_1 - e_2)$, together with the three rays $\tau_{ij} = \sigma_i \cap \sigma_j$ for $i \neq j$, and the origin. The toric variety X_{Σ} is covered by the affine opens

$$\begin{aligned} U_{\sigma_0} &= \text{Spec}(\mathbb{C}[S_{\sigma_0}]) \simeq \text{Spec}(\mathbb{C}[x, y]) \\ U_{\sigma_1} &= \text{Spec}(\mathbb{C}[S_{\sigma_1}]) \simeq \text{Spec}(\mathbb{C}[x^{-1}, x^{-1}y]) \\ U_{\sigma_2} &= \text{Spec}(\mathbb{C}[S_{\sigma_2}]) \simeq \text{Spec}(\mathbb{C}[xy^{-1}, y^{-1}]). \end{aligned}$$

Moreover, by Proposition 3.1.3, the gluing data on the coordinate rings is given by

$$\begin{aligned} g_{10}^* &: \mathbb{C}[x, y]_x \simeq \mathbb{C}[x^{-1}, x^{-1}y]_{x^{-1}} \\ g_{20}^* &: \mathbb{C}[x, y]_y \simeq \mathbb{C}[xy^{-1}, y^{-1}]_{y^{-1}} \\ g_{21}^* &: \mathbb{C}[x^{-1}, x^{-1}y]_{x^{-1}y} \simeq \mathbb{C}[xy^{-1}, y^{-1}]_{xy^{-1}}. \end{aligned}$$

It is easy to see that if we use the usual homogeneous coordinates (x_0, x_1, x_2) on \mathbb{P}^2 , then $x \mapsto \frac{x_1}{x_0}$ and $y \mapsto \frac{x_2}{x_0}$ identifies the standard affine open $U_i \subseteq \mathbb{P}^2$ with $U_{\sigma_i} \subseteq X_\Sigma$. Hence we have recovered \mathbb{P}^2 as the toric variety X_Σ . \diamond

Example 3.1.10. Generalizing Example 3.1.9, let $N_{\mathbb{R}} = \mathbb{R}^n$, where $N = \mathbb{Z}^n$ has standard basis e_1, \dots, e_n . Set

$$e_0 = -e_1 - e_2 - \cdots - e_n$$

and let Σ be the fan in $N_{\mathbb{R}}$ consisting of the cones generated by all proper subsets of $\{e_0, \dots, e_n\}$. This is the normal fan of the n -simplex Δ_n , and $X_\Sigma \simeq \mathbb{P}^n$ by Example 2.3.14 and Exercise 2.3.6. You will check the details to verify that this gives the usual affine open cover of \mathbb{P}^n in Exercise 3.1.3.

Example 3.1.11. We classify all 1-dimensional normal toric varieties as follows. We may assume $N = \mathbb{Z}$ and $N_{\mathbb{R}} = \mathbb{R}$. The only cones are the intervals $\sigma_0 = [0, \infty)$ and $\sigma_1 = (-\infty, 0]$ and the trivial cone $\tau = \{0\}$. It follows that there are only four possible fans, which gives the following list of toric varieties:

$$\begin{aligned} &\{\tau\}, \text{ which gives } \mathbb{C}^* \\ &\{\sigma_0, \tau\} \text{ and } \{\sigma_1, \tau\}, \text{ both of which give } \mathbb{C} \\ &\{\sigma_0, \sigma_1, \tau\}, \text{ which gives } \mathbb{P}^1. \end{aligned}$$

Here is a picture of the fan for \mathbb{P}^1 :

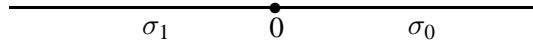

This is the fan of Example 3.1.10 when $n = 1$. \diamond

Example 3.1.12. By Example 2.4.8, $\mathbb{P}^n \times \mathbb{P}^m$ is the toric variety of the polytope $\Delta_n \times \Delta_m$. The normal fan of $\Delta_n \times \Delta_m$ is the product of the normal fans of each factor (Proposition 2.4.9). These normal fans are described in Example 3.1.10. It follows that the product fan Σ gives $X_\Sigma \simeq \mathbb{P}^n \times \mathbb{P}^m$.

When $n = m = 1$, we obtain the fan $\Sigma \subseteq \mathbb{R}^2 \simeq N_{\mathbb{R}}$ pictured in Figure 3 on the next page. Here, we can use an elementary gluing argument to show that this fan gives $\mathbb{P}^1 \times \mathbb{P}^1$. Label the 2-dimensional cones $\sigma_{ij} = \sigma_i \times \sigma'_j$ as above. Then

$$\begin{aligned} \text{Spec}(\mathbb{C}[S_{\sigma_{00}}]) &\simeq \mathbb{C}[x, y] \\ \text{Spec}(\mathbb{C}[S_{\sigma_{10}}]) &\simeq \mathbb{C}[x^{-1}, y] \\ \text{Spec}(\mathbb{C}[S_{\sigma_{11}}]) &\simeq \mathbb{C}[x^{-1}, y^{-1}] \\ \text{Spec}(\mathbb{C}[S_{\sigma_{01}}]) &\simeq \mathbb{C}[x, y^{-1}]. \end{aligned}$$

We see that if U_0 and U_1 are the standard affine open sets in \mathbb{P}^1 , then $U_{\sigma_{ij}} \simeq U_i \times U_j$ and it is easy to check that the gluing makes $X_\Sigma \simeq \mathbb{P}^1 \times \mathbb{P}^1$. \diamond

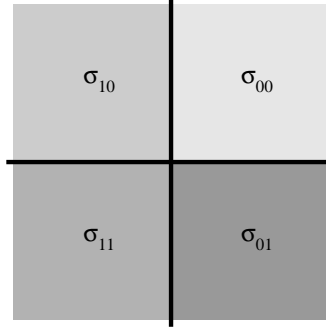

Figure 3. A fan Σ with $X_\Sigma \simeq \mathbb{P}^1 \times \mathbb{P}^1$

Example 3.1.13. Let $N = N_1 \times N_2$, with $N_1 = \mathbb{Z}^n$ and $N_2 = \mathbb{Z}^m$. Let Σ_1 in $(N_1)_{\mathbb{R}}$ be the fan giving \mathbb{P}^n , but let Σ_2 be the fan consisting of the cone $\text{Cone}(e_1, \dots, e_m)$ together with all its faces. Then $\Sigma = \Sigma_1 \times \Sigma_2$ is a fan in $N_{\mathbb{R}}$ and the corresponding toric variety is $X_\Sigma \simeq \mathbb{P}^n \times \mathbb{C}^m$. The case $\mathbb{P}^1 \times \mathbb{C}^2$ was studied in Example 3.0.14. \diamond

Examples 3.1.12 and 3.1.13 are special cases of the following general construction, whose proof will be left to the reader (Exercise 3.1.4).

Proposition 3.1.14. *Suppose we have fans Σ_1 in $(N_1)_{\mathbb{R}}$ and Σ_2 in $(N_2)_{\mathbb{R}}$. Then*

$$\Sigma_1 \times \Sigma_2 = \{\sigma_1 \times \sigma_2 \mid \sigma_i \in \Sigma_i\}$$

is a fan in $N_1 \times N_2$ and

$$X_{\Sigma_1 \times \Sigma_2} \simeq X_{\Sigma_1} \times X_{\Sigma_2}. \quad \square$$

Example 3.1.15. The two cones σ_1 and σ_2 in $N_{\mathbb{R}} = \mathbb{R}^2$ from Example 3.1.4 (see Figure 1), together with their faces, form a fan Σ . By comparing the descriptions of the coordinate rings of V_{σ_i} given there with what we did in Example 3.0.8, it is easy to check that $X_\Sigma \simeq W$, where $W \subseteq \mathbb{P}^1 \times \mathbb{C}^2$ is the blowup of \mathbb{C}^2 at the origin, defined as $W = \mathbf{V}(x_0y - x_1x)$ (Exercise 3.1.5).

Generalizing this, let $N = \mathbb{Z}^n$ with standard basis e_1, \dots, e_n and then set $e_0 = e_1 + \dots + e_n$. Let Σ be the fan in $N_{\mathbb{R}}$ consisting of the cones generated by all subsets of $\{e_0, \dots, e_n\}$ not containing $\{e_1, \dots, e_n\}$. Then the toric variety X_Σ is isomorphic to the blowup of \mathbb{C}^n at the origin (Exercise 3.0.8). \diamond

Example 3.1.16. Let $r \in \mathbb{Z}_{\geq 0}$ and consider the fan Σ_r in $N_{\mathbb{R}} = \mathbb{R}^2$ consisting of the four cones σ_i shown in Figure 4 on the next page, together with all of their faces.

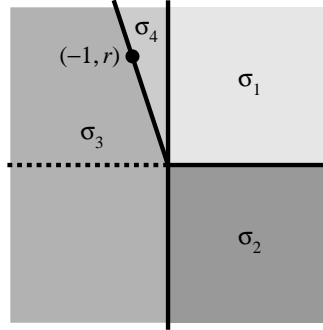

Figure 4. A fan Σ_r with $X_{\Sigma_r} \simeq \mathcal{H}_r$

The corresponding toric variety X_{Σ_r} is covered by open affine subsets,

$$U_{\sigma_1} = \text{Spec}(\mathbb{C}[x, y]) \simeq \mathbb{C}^2$$

$$U_{\sigma_2} = \text{Spec}(\mathbb{C}[x, y^{-1}]) \simeq \mathbb{C}^2$$

$$U_{\sigma_3} = \text{Spec}(\mathbb{C}[x^{-1}, x^{-r}y^{-1}]) \simeq \mathbb{C}^2$$

$$U_{\sigma_4} = \text{Spec}(\mathbb{C}[x^{-1}, x^r y]) \simeq \mathbb{C}^2,$$

and glued according to (3.1.3). We call X_{Σ_r} the *Hirzebruch surface* \mathcal{H}_r .

Example 2.3.15 constructed the *rational normal scroll* $S_{a,b}$ using the polygon $P_{a,b}$ with $b \geq a \geq 1$. The normal fan of $P_{a,b}$ is the fan Σ_{b-a} defined above, so that as an abstract variety, $S_{a,b} \simeq \mathcal{H}_{b-a}$. Note also that $\mathcal{H}_0 \simeq \mathbb{P}^1 \times \mathbb{P}^1$. \diamond

The Hirzebruch surfaces \mathcal{H}_r will play an important role in the classification of smooth projective toric surfaces given in Chapter 10.

Example 3.1.17. Let $q_0, \dots, q_n \in \mathbb{Z}_{>0}$ satisfy $\gcd(q_0, \dots, q_n) = 1$. Consider the weighted projective space $\mathbb{P}(q_0, \dots, q_n)$ introduced in Chapter 2. Define the lattice $N = \mathbb{Z}^{n+1} / \mathbb{Z} \cdot (q_0, \dots, q_n)$ and let $u_i, i = 0, \dots, n$, be the images in N of the standard basis vectors in \mathbb{Z}^{n+1} , so the relation

$$q_0 u_0 + \dots + q_n u_n = 0$$

holds in N . Let Σ be the fan made up of the cones generated by all the proper subsets of $\{u_0, \dots, u_n\}$. When $q_i = 1$ for all i , we obtain $X_\Sigma \simeq \mathbb{P}^n$ by Example 3.1.10. And indeed, $X_\Sigma \simeq \mathbb{P}(q_0, \dots, q_n)$ in general. This will be proved in Chapter 5 using the toric generalization of homogeneous coordinates in \mathbb{P}^n .

Here, we will consider the special case $\mathbb{P}(1, 1, 2)$, where $u_0 = -u_1 - 2u_2$. The fan Σ in $N_{\mathbb{R}}$ is pictured in Figure 5 on the next page, using the plane spanned by u_1, u_2 . This example is different from the ones we have seen so far. Consider $\sigma_2 = \text{Cone}(u_0, u_1) = \text{Cone}(-u_1 - 2u_2, u_1)$. Then $\sigma_2^\vee = \text{Cone}(-u_2, 2u_1 - u_2) \subseteq M$, so the situation is similar to the case studied in Example 1.2.21. Indeed, there is a change

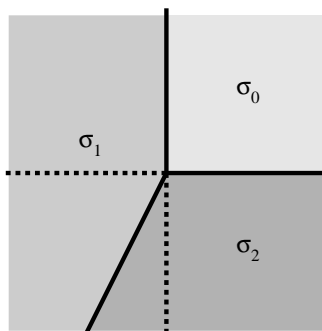

Figure 5. A fan Σ with $X_\Sigma \simeq \mathbb{P}(1, 1, 2)$

of coordinates defined by a matrix in $\mathrm{GL}(2, \mathbb{Z})$ that takes σ to the cone with $d = 2$ from that example. It follows that there is an isomorphism $U_{\sigma_2} \simeq \mathbf{V}(xz - y^2) \subseteq \mathbb{C}^3$ (Exercise 3.1.6). This is the rational normal cone \widehat{C}_2 , hence has a singular point at the origin. The toric variety X_Σ is singular because of the singular point in this affine open subset.

In Example 2.4.6, we saw that the polytope $P = \mathrm{Conv}(0, 2e_1, e_2) \subseteq \mathbb{R}^2$ gives $X_P \simeq \mathbb{P}(1, 1, 2)$ and that the normal fan Σ_P coincides with the fan shown above. \diamond

There is a dictionary between properties of X_Σ and properties of Σ that generalizes Theorem 1.3.12 and Example 1.3.20. We begin with some terminology. The first two items parallel Definition 1.2.16.

Definition 3.1.18. Let $\Sigma \subseteq N_{\mathbb{R}}$ be a fan.

- (a) We say Σ is *smooth* (or *regular*) if every cone σ in Σ is smooth (or regular).
- (b) We say Σ is *simplicial* if every cone σ in Σ is simplicial.
- (c) We say Σ is *complete* if its support $|\Sigma| = \bigcup_{\sigma \in \Sigma} \sigma$ is all of $N_{\mathbb{R}}$.

Theorem 3.1.19. Let X_Σ be the toric variety defined by a fan $\Sigma \subseteq N_{\mathbb{R}}$.

- (a) X_Σ is a smooth variety if and only if the fan Σ is smooth.
- (b) X_Σ is an orbifold (that is, X_Σ has only finite quotient singularities) if and only if the fan Σ is simplicial.
- (c) X_Σ is compact in the classical topology if and only if Σ is complete.

Proof. Part (a) follows from the corresponding statement for affine toric varieties, Theorem 1.3.12, because smoothness is a local property (Definition 3.0.13). In part (b), Example 1.3.20 gives one implication. The other implication will be proved in Chapter 11. A proof of part (c) will be given in §3.4. \square

The blowup of \mathbb{C}^2 at the origin (Example 3.1.15) is not compact, since the support of the cones in the corresponding fan is not all of \mathbb{R}^2 . The Hirzebruch

surfaces \mathcal{H}_r from Example 3.1.16 are smooth and compact because every cone in the corresponding fan is smooth, and the union of the cones is \mathbb{R}^2 . The variety $\mathbb{P}(1, 1, 2)$ from Example 3.1.17 is compact but not smooth. It is an orbifold (it has only finite quotient singularities) since the corresponding fan is simplicial.

Exercises for §3.1.

3.1.1. Let Σ be a fan in $N_{\mathbb{R}}$. Show that the isomorphisms g_{σ_1, σ_2} satisfy the compatibility conditions from §0 for gluing the U_{σ} together to create X_{Σ} .

3.1.2. Let X be a variety obtained by gluing affine open subsets $\{V_{\alpha}\}$ along open subsets $V_{\alpha\beta} \subseteq V_{\alpha}$ by isomorphisms $g_{\alpha\beta} : V_{\alpha\beta} \simeq V_{\beta\alpha}$. Show that X is separated when the image of $\Delta : V_{\alpha\beta} \rightarrow V_{\alpha} \times V_{\beta}$ defined by $\Delta(p) = (p, g_{\alpha\beta}(p))$ is Zariski closed for all α, β .

3.1.3. Verify that if Σ is the fan given in Example 3.1.10, then $X_{\Sigma} \simeq \mathbb{P}^n$.

3.1.4. Prove Proposition 3.1.14.

3.1.5. Let $N \simeq \mathbb{Z}^n$, let $e_1, \dots, e_n \in N$ be the standard basis and let $e_0 = e_1 + \dots + e_n$. Let Σ be the set of cones generated by all subsets of $\{e_0, \dots, e_n\}$ not containing $\{e_1, \dots, e_n\}$.

- Show that Σ is a fan in $N_{\mathbb{R}}$.
- Construct the affine open subsets covering the corresponding toric variety X_{Σ} , and give the gluing isomorphisms.
- Show that X_{Σ} is isomorphic to the blowup of \mathbb{C}^n at the origin, described earlier in Exercise 3.0.8. Hint: The blowup is the subvariety of $\mathbb{P}^{n-1} \times \mathbb{C}^n$ given by $W = \mathbf{V}(x_i y_j - x_j y_i \mid 1 \leq i < j \leq n)$. Cover W by affine open subsets $W_i = W_{x_i}$ and compare those affines with your answer to part (b).

3.1.6. In this exercise, you will verify the claims made in Example 3.1.17.

- Show that there is a matrix $A \in \text{GL}(2, \mathbb{Z})$ defining a change of coordinates that takes the cone in this example to the cone from Example 1.2.21, and find the mapping that takes σ_2^{\vee} to the dual cone.
- Show that $\text{Spec}(\mathbb{C}[S_{\sigma_2}]) \simeq \mathbf{V}(xz - y^2) \subseteq \mathbb{C}^3$.

3.1.7. In $N_{\mathbb{R}} = \mathbb{R}^2$, consider the fan Σ with cones $\{0\}$, $\text{Cone}(e_1)$, and $\text{Cone}(-e_1)$. Show that $X_{\Sigma} \simeq \mathbb{P}^1 \times \mathbb{C}^*$.

§3.2. The Orbit-Cone Correspondence

In this section, we will study the orbits for the action of T_N on the toric variety X_{Σ} . Our main result will show that there is a bijective correspondence between cones in Σ and T_N -orbits in X_{Σ} . The connection comes ultimately from looking at limit points of *one-parameter subgroups* of T_N defined in §1.1.

A First Example. We introduce the key features of the correspondence between orbits and cones by looking at a concrete example.

Example 3.2.1. Consider $\mathbb{P}^2 \simeq X_\Sigma$ for the fan Σ from Figure 2 of §3.1. The torus $T_N = (\mathbb{C}^*)^2 \subseteq \mathbb{P}^2$ consists of points with homogeneous coordinates $(1, s, t)$, $s, t \neq 0$. For each $u = (a, b) \in N = \mathbb{Z}^2$, we have the corresponding curve in \mathbb{P}^2 :

$$\lambda^u(t) = (1, t^a, t^b).$$

We are abusing notation slightly; strictly speaking, the one-parameter subgroup λ^u is a curve in $(\mathbb{C}^*)^2$, but we view it as a curve in \mathbb{P}^2 via the inclusion $(\mathbb{C}^*)^2 \subseteq \mathbb{P}^2$.

We start by analyzing the limit of $\lambda^u(t)$ as $t \rightarrow 0$. The limit point in \mathbb{P}^2 depends on $u = (a, b)$. It is easy to check that the pattern is as follows:

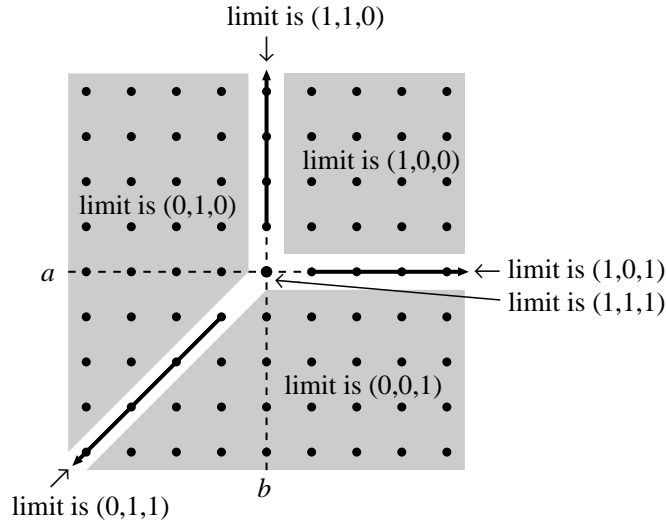

Figure 6. $\lim_{t \rightarrow 0} \lambda^u(t)$ for $u = (a, b) \in \mathbb{Z}^2$

For instance, suppose $a, b > 0$ in \mathbb{Z} . These points lie in the first quadrant. Here, it is obvious that $\lim_{t \rightarrow 0} (1, t^a, t^b) = (1, 0, 0)$. Next suppose that $a = b < 0$ in \mathbb{Z} , corresponding to points on the diagonal in the third quadrant. Note that

$$(1, t^a, t^b) = (1, t^a, t^a) \sim (t^{-a}, 1, 1)$$

since we are using homogeneous coordinates in \mathbb{P}^2 . Then $-a > 0$ implies that $\lim_{t \rightarrow 0} (t^{-a}, 1, 1) = (0, 1, 1)$. You will check the remaining cases in Exercise 3.2.1.

The regions of N described in Figure 6 correspond to cones of the fan Σ . In each case, the set of u giving one of the limit points equals $N \cap \text{Relint}(\sigma)$, where $\text{Relint}(\sigma)$ is the *relative interior* of a cone $\sigma \in \Sigma$. In other words, we have recovered the structure of the fan Σ by considering these limits!

Now we relate this to the T_N -orbits in \mathbb{P}^2 . By considering the description $\mathbb{P}^2 \simeq (\mathbb{C}^3 \setminus \{0\})/\mathbb{C}^*$, you will see in Exercise 3.2.1 that there are exactly seven T_N -orbits

in \mathbb{P}^2 :

$$\begin{aligned}
O_1 &= \{(x_0, x_1, x_2) \mid x_i \neq 0 \text{ for all } i\} \ni (1, 1, 1) \\
O_2 &= \{(x_0, x_1, x_2) \mid x_2 = 0, \text{ and } x_0, x_1 \neq 0\} \ni (1, 1, 0) \\
O_3 &= \{(x_0, x_1, x_2) \mid x_1 = 0, \text{ and } x_0, x_2 \neq 0\} \ni (1, 0, 1) \\
O_4 &= \{(x_0, x_1, x_2) \mid x_0 = 0, \text{ and } x_1, x_2 \neq 0\} \ni (0, 1, 1) \\
O_5 &= \{(x_0, x_1, x_2) \mid x_1 = x_2 = 0, \text{ and } x_0 \neq 0\} = \{(1, 0, 0)\} \\
O_6 &= \{(x_0, x_1, x_2) \mid x_0 = x_2 = 0, \text{ and } x_1 \neq 0\} = \{(0, 1, 0)\} \\
O_7 &= \{(x_0, x_1, x_2) \mid x_0 = x_1 = 0, \text{ and } x_2 \neq 0\} = \{(0, 0, 1)\}.
\end{aligned}$$

This list shows that each orbit contains a unique limit point. Hence we obtain a correspondence between cones σ and orbits O by

$$\sigma \text{ corresponds to } O \iff \lim_{t \rightarrow 0} \lambda^u(t) \in O \text{ for all } u \in \text{Relint}(\sigma).$$

We will soon see that these observations generalize to all toric varieties X_Σ . \diamond

Points and Semigroup Homomorphisms. It will be convenient to use the intrinsic description of the points of an affine toric variety U_σ given in Proposition 1.3.1. We recall how this works and make some additional observations:

- Points of U_σ are in bijective correspondence with semigroup homomorphisms $\gamma : S_\sigma \rightarrow \mathbb{C}$. Recall that $S_\sigma = \sigma^\vee \cap M$ and $U_\sigma = \text{Spec}(\mathbb{C}[S_\sigma])$.
- For each cone σ we have a point of U_σ defined by

$$m \in S_\sigma \longmapsto \begin{cases} 1 & m \in S_\sigma \cap \sigma^\perp = \sigma^\perp \cap M \\ 0 & \text{otherwise.} \end{cases}$$

This is a semigroup homomorphism since $\sigma^\vee \cap \sigma^\perp$ is a face of σ^\vee . Thus, if $m, m' \in S_\sigma$ and $m + m' \in S_\sigma \cap \sigma^\perp$, then $m, m' \in S_\sigma \cap \sigma^\perp$. We denote this point by γ_σ and call it the *distinguished point* corresponding to σ .

- The point γ_σ is fixed under the T_N -action if and only if $\dim \sigma = \dim M_{\mathbb{R}}$ (Corollary 1.3.3).
- If $\tau \preceq \sigma$ is a face, then $\gamma_\tau \in U_\sigma$. This follows since $\sigma^\perp \subseteq \tau^\perp$.

Limits of One-Parameter Subgroups. In Example 3.2.1, the limit points of one-parameter subgroups are exactly the distinguished points for the cones in the fan of \mathbb{P}^2 (Exercise 3.2.1). We now show that this is true for all affine toric varieties.

Proposition 3.2.2. *Let $\sigma \subseteq N_{\mathbb{R}}$ be a strongly convex rational polyhedral cone and let $u \in N$. Then*

$$u \in \sigma \iff \lim_{t \rightarrow 0} \lambda^u(t) \text{ exists in } U_\sigma.$$

Moreover, if $u \in \text{Relint}(\sigma)$, then $\lim_{t \rightarrow 0} \lambda^u(t) = \gamma_\sigma$.

Proof. Given $u \in N$, we have

$$\begin{aligned} \lim_{t \rightarrow 0} \lambda^u(t) \text{ exists in } U_\sigma &\iff \lim_{t \rightarrow 0} \chi^m(\lambda^u(t)) \text{ exists in } \mathbb{C} \text{ for all } m \in S_\sigma \\ &\iff \lim_{t \rightarrow 0} t^{\langle m, u \rangle} \text{ exists in } \mathbb{C} \text{ for all } m \in S_\sigma \\ &\iff \langle m, u \rangle \geq 0 \text{ for all } m \in \sigma^\vee \cap M \\ &\iff u \in (\sigma^\vee)^\vee = \sigma, \end{aligned}$$

where the first equivalence is proved in Exercise 3.2.2 and the other equivalences are clear. This proves the first assertion of the proposition.

In Exercise 3.2.2 you will also show that when $u \in \sigma \cap N$, $\lim_{t \rightarrow 0} \lambda^u(t)$ is the point corresponding to the semigroup homomorphism $S_\sigma \rightarrow \mathbb{C}$ defined by

$$m \in \sigma^\vee \cap M \longmapsto \lim_{t \rightarrow 0} t^{\langle m, u \rangle}.$$

If $u \in \text{Relint}(\sigma)$, then $\langle m, u \rangle > 0$ for all $m \in S_\sigma \setminus \sigma^\perp$ (Exercise 1.2.2), and $\langle m, u \rangle = 0$ if $m \in S_\sigma \cap \sigma^\perp$. Hence the limit point is precisely the distinguished point γ_σ . \square

Using this proposition, we can recover the fan Σ from X_Σ cone by cone as in Example 3.2.1. This is also the key observation needed for the proof of Corollary 3.1.8 from the previous section.

Let us apply Proposition 3.2.2 to a familiar example.

Example 3.2.3. Consider the affine toric variety $V = \mathbf{V}(xy - zw)$ studied in a number of examples from Chapter 1. For instance, in Example 1.1.18, we showed that V is the normal toric variety corresponding to a cone σ whose dual cone is

$$(3.2.1) \quad \sigma^\vee = \text{Cone}(e_1, e_2, e_3, e_1 + e_2 - e_3),$$

and $V = \text{Spec}(\mathbb{C}[\sigma^\vee \cap M])$.

In Example 1.1.18, we introduced the torus $T = (\mathbb{C}^*)^3$ of V as the image of

$$(3.2.2) \quad (t_1, t_2, t_3) \mapsto (t_1, t_2, t_3, t_1 t_2 t_3^{-1}).$$

Given $u = (a, b, c) \in N = \mathbb{Z}^3$, we have the one-parameter subgroup

$$(3.2.3) \quad \lambda^u(t) = (t^a, t^b, t^c, t^{a+b-c})$$

contained in V , and we proceed to examine limit points using Proposition 3.2.2. Clearly, $\lim_{t \rightarrow 0} \lambda^u(t)$ exists in V if and only if $a, b, c \geq 0$ and $a + b \geq c$. These conditions determine the cone $\sigma \subseteq N_\mathbb{R}$ given by

$$(3.2.4) \quad \sigma = \text{Cone}(e_1, e_2, e_1 + e_3, e_2 + e_3).$$

One easily checks that (3.2.1) is the dual of this cone (Exercise 3.2.3). Note also that $u \in \text{Relint}(\sigma)$ means $a, b, c > 0$ and $a + b > c$, in which case the limit $\lim_{t \rightarrow 0} \lambda^u(t) = (0, 0, 0, 0)$, which is the distinguished point γ_σ . \diamond

The Torus Orbits. Now we turn to the T_N -orbits in X_Σ . We saw above that each cone $\sigma \in \Sigma$ has a distinguished point $\gamma_\sigma \in U_\sigma \subseteq X_\Sigma$. This gives the torus orbit

$$O(\sigma) = T_N \cdot \gamma_\sigma \subseteq X_\Sigma.$$

In order to determine the structure of $O(\sigma)$, we need the following lemma, which you will prove in Exercise 3.2.4.

Lemma 3.2.4. *Let σ be a strongly convex rational polyhedral cone in $N_\mathbb{R}$. Let N_σ be the sublattice of N spanned by the points in $\sigma \cap N$, and let $N(\sigma) = N/N_\sigma$.*

(a) *There is a perfect pairing*

$$\langle \cdot, \cdot \rangle : \sigma^\perp \cap M \times N(\sigma) \rightarrow \mathbb{Z},$$

induced by the dual pairing $\langle \cdot, \cdot \rangle : M \times N \rightarrow \mathbb{Z}$.

(b) *The pairing of part (a) induces a natural isomorphism*

$$\mathrm{Hom}_\mathbb{Z}(\sigma^\perp \cap M, \mathbb{C}^*) \simeq T_{N(\sigma)},$$

where $T_{N(\sigma)} = N(\sigma) \otimes_\mathbb{Z} \mathbb{C}^$ is the torus associated to $N(\sigma)$. \square*

To study $O(\sigma) \subseteq U_\sigma$, we recall how $t \in T_N$ acts on semigroup homomorphisms. If $p \in U_\sigma$ is represented by $\gamma : S_\sigma \rightarrow \mathbb{C}$, then by Exercise 1.3.1, the point $t \cdot p$ is represented by the semigroup homomorphism

$$(3.2.5) \quad t \cdot \gamma : m \mapsto \chi^m(t) \gamma(m).$$

Lemma 3.2.5. *Let σ be a strongly convex rational polyhedral cone in $N_\mathbb{R}$. Then*

$$\begin{aligned} O(\sigma) &= \{ \gamma : S_\sigma \rightarrow \mathbb{C} \mid \gamma(m) \neq 0 \Leftrightarrow m \in \sigma^\perp \cap M \} \\ &\simeq \mathrm{Hom}_\mathbb{Z}(\sigma^\perp \cap M, \mathbb{C}^*) \simeq T_{N(\sigma)}, \end{aligned}$$

where $N(\sigma)$ is the lattice defined in Lemma 3.2.4.

Proof. The set $O' = \{ \gamma : S_\sigma \rightarrow \mathbb{C} \mid \gamma(m) \neq 0 \Leftrightarrow m \in \sigma^\perp \cap M \}$ contains γ_σ and is invariant under the action of T_N described in (3.2.5).

Next observe that σ^\perp is the largest vector subspace of $M_\mathbb{R}$ contained in σ^\vee . Hence $\sigma^\perp \cap M$ is a subgroup of $S_\sigma = \sigma^\vee \cap M$. If $\gamma \in O'$, then restricting γ to $m \in S_\sigma \cap \sigma^\perp = \sigma^\perp \cap M$ yields a group homomorphism $\hat{\gamma} : \sigma^\perp \cap M \rightarrow \mathbb{C}^*$ (Exercise 3.2.5). Conversely, if $\hat{\gamma} : \sigma^\perp \cap M \rightarrow \mathbb{C}^*$ is a group homomorphism, we obtain a semigroup homomorphism $\gamma \in O'$ by defining

$$\gamma(m) = \begin{cases} \hat{\gamma}(m) & \text{if } m \in \sigma^\perp \cap M \\ 0 & \text{otherwise.} \end{cases}$$

It follows that $O' \simeq \mathrm{Hom}_\mathbb{Z}(\sigma^\perp \cap M, \mathbb{C}^*)$.

Now consider the exact sequence

$$(3.2.6) \quad 0 \longrightarrow N_\sigma \longrightarrow N \longrightarrow N(\sigma) \longrightarrow 0.$$

Tensoring with \mathbb{C}^* and using Lemma 3.2.4, we obtain a surjection

$$T_N = N \otimes_{\mathbb{Z}} \mathbb{C}^* \longrightarrow T_{N(\sigma)} = N(\sigma) \otimes_{\mathbb{Z}} \mathbb{C}^* \simeq \text{Hom}_{\mathbb{Z}}(\sigma^\perp \cap M, \mathbb{C}^*).$$

The bijections

$$T_{N(\sigma)} \simeq \text{Hom}_{\mathbb{Z}}(\sigma^\perp \cap M, \mathbb{C}^*) \simeq \mathcal{O}'$$

are compatible with the T_N -action, so that T_N acts transitively on \mathcal{O}' . Then $\gamma_\sigma \in \mathcal{O}'$ implies that $\mathcal{O}' = T_N \cdot \gamma_\sigma = \mathcal{O}(\sigma)$, as desired. \square

The Orbit-Cone Correspondence. Our next theorem is the major result of this section. Recall that the face relation $\tau \preceq \sigma$ holds when τ is a face of σ .

Theorem 3.2.6 (Orbit-Cone Correspondence). *Let X_Σ be the toric variety of the fan Σ in $N_{\mathbb{R}}$.*

(a) *There is a bijective correspondence*

$$\begin{aligned} \{\text{cones } \sigma \text{ in } \Sigma\} &\longleftrightarrow \{T_N\text{-orbits in } X_\Sigma\} \\ \sigma &\longleftrightarrow \mathcal{O}(\sigma) \simeq \text{Hom}_{\mathbb{Z}}(\sigma^\perp \cap M, \mathbb{C}^*). \end{aligned}$$

(b) *Let $n = \dim N_{\mathbb{R}}$. For each cone $\sigma \in \Sigma$, $\dim \mathcal{O}(\sigma) = n - \dim \sigma$.*

(c) *The affine open subset U_σ is the union of orbits*

$$U_\sigma = \bigcup_{\tau \preceq \sigma} \mathcal{O}(\tau).$$

(d) *$\tau \preceq \sigma$ if and only if $\mathcal{O}(\sigma) \subseteq \overline{\mathcal{O}(\tau)}$, and*

$$\overline{\mathcal{O}(\tau)} = \bigcup_{\tau \preceq \sigma} \mathcal{O}(\sigma),$$

where $\overline{\mathcal{O}(\tau)}$ denotes the closure in both the classical and Zariski topologies.

For instance, Example 3.2.1 tells us that for \mathbb{P}^2 , there are three types of cones and torus orbits:

- The trivial cone $\sigma = \{(0,0)\}$ corresponds to the orbit $\mathcal{O}(\sigma) = T_N \subseteq \mathbb{P}^2$, which satisfies $\dim \mathcal{O}(\sigma) = 2 = 2 - \dim \sigma$. This is a face of all the other cones in Σ , and hence all the other orbits are contained in the closure of this one by part (d). Note also that $U_\sigma = \mathcal{O}(\sigma) \simeq (\mathbb{C}^*)^2$ by part (c), since there are no cones properly contained in σ .
- The three 1-dimensional cones τ give the torus orbits of dimension 1. Each is isomorphic to \mathbb{C}^* . The closures of these orbits are the coordinate axes $\mathbf{V}(x_i)$ in \mathbb{P}^2 , each a copy of \mathbb{P}^1 . Note that each τ is contained in two maximal cones.
- The three maximal cones σ_i in the fan Σ correspond to the three fixed points $(1,0,0), (0,1,0), (0,0,1)$ of the torus action on \mathbb{P}^2 . There are two of these in the closure of each of the 1-dimensional torus orbits.

Proof of Theorem 3.2.6. Let O be a T_N -orbit in X_Σ . Since X_Σ is covered by the T_N -invariant affine open subsets $U_\sigma \subseteq X_\Sigma$ and $U_{\sigma_1} \cap U_{\sigma_2} = U_{\sigma_1 \cap \sigma_2}$, there is a unique minimal cone $\sigma \in \Sigma$ with $O \subseteq U_\sigma$. We claim that $O = O(\sigma)$. Note that part (a) will follow immediately once we prove this claim.

To prove the claim, let $\gamma \in O$ and consider those $m \in S_\sigma$ satisfying $\gamma(m) \neq 0$. In Exercise 3.2.6, you will show that these m 's lie on a face of σ^\vee . But faces of σ^\vee are all of the form $\sigma^\vee \cap \tau^\perp$ for some face $\tau \preceq \sigma$ by Proposition 1.2.10. In other words, there is a face $\tau \preceq \sigma$ such that

$$\{m \in S_\sigma \mid \gamma(m) \neq 0\} = \sigma^\vee \cap \tau^\perp \cap M.$$

This easily implies $\gamma \in U_\tau$ (Exercise 3.2.6), and then $\tau = \sigma$ by the minimality of σ . Hence $\{m \in S_\sigma \mid \gamma(m) \neq 0\} = \sigma^\perp \cap M$, and then $\gamma \in O(\sigma)$ by Lemma 3.2.5. This implies $O = O(\sigma)$ since two orbits are either equal or disjoint.

Part (b) follows from Lemma 3.2.5 and (3.2.6).

Next consider part (c). We know that U_σ is a union of orbits. If τ is a face of σ , then $O(\tau) \subseteq U_\tau \subseteq U_\sigma$ implies that $O(\tau)$ is an orbit contained in U_σ . Furthermore, the analysis of part (a) easily implies that any orbit contained in U_σ must equal $O(\tau)$ for some face $\tau \preceq \sigma$.

We now turn to part (d). We begin with the closure of $O(\tau)$ in the classical topology, which we denote $\overline{O(\tau)}$. This is invariant under T_N (Exercise 3.2.6) and hence is a union of orbits. Suppose that $O(\sigma) \subseteq \overline{O(\tau)}$. Then $O(\tau) \subseteq U_\sigma$, since otherwise $O(\tau) \cap U_\sigma = \emptyset$, which would imply $\overline{O(\tau)} \cap U_\sigma = \emptyset$ since U_σ is open in the classical topology. Once we have $O(\tau) \subseteq U_\sigma$, it follows that $\tau \preceq \sigma$ by part (c). Conversely, assume $\tau \preceq \sigma$. To prove that $O(\sigma) \subseteq \overline{O(\tau)}$, it suffices to show that $\overline{O(\tau)} \cap O(\sigma) \neq \emptyset$. We will do this by using limits of one-parameter subgroups as in Proposition 3.2.2.

Let γ_τ be the semigroup homomorphism corresponding to the distinguished point of U_τ , so $\gamma_\tau(m) = 1$ if $m \in \tau^\perp \cap M$, and 0 otherwise. Let $u \in \text{Relint}(\sigma)$, and for $t \in \mathbb{C}^*$ define $\gamma(t) = \lambda^u(t) \cdot \gamma_\tau$. As a semigroup homomorphism, $\gamma(t)$ is

$$m \longmapsto \chi^m(\lambda^u(t)) \gamma_\tau(m) = t^{\langle m, u \rangle} \gamma_\tau(m).$$

Note that $\gamma(t) \in O(\tau)$ for all $t \in \mathbb{C}^*$ since the orbit of γ_τ is $O(\tau)$. Now let $t \rightarrow 0$. Since $u \in \text{Relint}(\sigma)$, $\langle m, u \rangle > 0$ if $m \in \sigma^\vee \setminus \sigma^\perp$, and $= 0$ if $m \in \sigma^\perp$. It follows that $\gamma(0) = \lim_{t \rightarrow 0} \gamma(t)$ exists as a point in U_σ by Proposition 3.2.2, and represents a point in $O(\sigma)$. But it is also in the closure of $O(\tau)$ by construction, so that $O(\sigma) \cap \overline{O(\tau)} \neq \emptyset$. This establishes the first assertion of (d), and

$$\overline{O(\tau)} = \bigcup_{\tau \preceq \sigma} O(\sigma)$$

follows immediately for the classical topology.

It remains to show that this set is also the Zariski closure. If we intersect $\overline{O(\tau)}$ with an affine open subset $U_{\sigma'}$, parts (c) and (d) imply that

$$\overline{O(\tau)} \cap U_{\sigma'} = \bigcup_{\tau \preceq \sigma' \preceq \sigma} O(\sigma).$$

In Exercise 3.2.6, you will show that this is the subvariety $\mathbf{V}(I) \subseteq U_{\sigma'}$ for the ideal

$$(3.2.7) \quad I = \langle \chi^m \mid m \in \tau^\perp \cap (\sigma')^\vee \cap M \rangle \subseteq \mathbb{C}[(\sigma')^\vee \cap M] = S_{\sigma'}.$$

This easily implies that the classical closure $\overline{O(\tau)}$ is a subvariety of X_Σ and hence is the Zariski closure of $O(\tau)$. \square

Orbit Closures as Toric Varieties. In the example of \mathbb{P}^2 , the orbit closures $\overline{O(\tau)}$ also have the structure of toric varieties. This holds in general. We use the notation

$$V(\tau) = \overline{O(\tau)}.$$

By part (d) of Theorem 3.2.6, we have $\tau \preceq \sigma$ if and only if $O(\sigma) \subseteq V(\tau)$, and

$$V(\tau) = \bigcup_{\tau \preceq \sigma} O(\sigma).$$

The torus $O(\tau) = T_{N(\tau)}$ is an open subset of $V(\tau)$, where $N(\tau)$ is defined in Lemma 3.2.4. We will show that $V(\tau)$ is a normal toric variety by constructing its fan. For each cone $\sigma \in \Sigma$ containing τ , let $\bar{\sigma}$ be the image cone in $N(\tau)_\mathbb{R}$ under the quotient map

$$N_\mathbb{R} \longrightarrow N(\tau)_\mathbb{R}$$

in (3.2.6). Then

$$(3.2.8) \quad \text{Star}(\tau) = \{\bar{\sigma} \subseteq N(\tau)_\mathbb{R} \mid \tau \preceq \sigma \in \Sigma\}$$

is a fan in $N(\tau)_\mathbb{R}$ (Exercise 3.2.7).

Proposition 3.2.7. *For any $\tau \in \Sigma$, the orbit closure $V(\tau) = \overline{O(\tau)}$ is isomorphic to the toric variety $X_{\text{Star}(\tau)}$.*

Proof. This follows from parts (a) and (d) of Theorem 3.2.6 (Exercise 3.2.7). \square

Example 3.2.8. Consider the fan Σ in $N_\mathbb{R} = \mathbb{R}^3$ shown in Figure 7 on the next page. The support of Σ is the cone in Figure 2 of Chapter 1, and Σ is obtained from this cone by adding a new 1-dimensional cone τ in the center and subdividing. The orbit $O(\tau)$ has dimension 2 by Theorem 3.2.6. By Proposition 3.2.7, the orbit closure $V(\tau)$ is constructed from the cones of Σ containing τ and then collapsing τ to a point in $N(\tau)_\mathbb{R} = (N/N_\tau)_\mathbb{R} \simeq \mathbb{R}^2$. This clearly gives the fan for $\mathbb{P}^1 \times \mathbb{P}^1$, so that $V(\tau) \simeq \mathbb{P}^1 \times \mathbb{P}^1$. \diamond

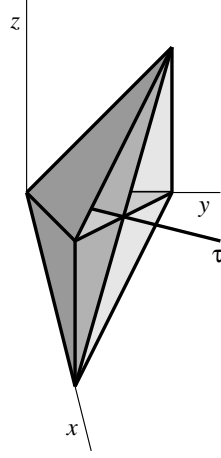

Figure 7. The fan Σ and its 1-dimensional cone τ

A nice example of orbit closures comes from the toric variety X_P of a full dimensional lattice polytope $P \subseteq M_{\mathbb{R}}$. Here, we use the normal fan Σ_P of P , which by Theorem 2.3.2 consists of cones

$$(3.2.9) \quad \sigma_Q = \text{Cone}(u_F \mid F \text{ is a facet of } P \text{ containing } Q)$$

for each face $Q \preceq P$. Recall that u_F is the facet normal of F .

The basic idea is that the orbit closure of $V(\sigma_Q)$ is the toric variety of the lattice polytope Q . Since Q need not be full dimensional in $M_{\mathbb{R}}$, we need to be careful. The idea is to translate P by a vertex of Q so that the origin is a vertex of Q . This affects neither Σ_P nor X_P , but Q is now full dimensional in $\text{Span}(Q)$ and is a lattice polytope relative to $\text{Span}(Q) \cap M$. This gives the toric variety X_Q , which is easily seen to be independent of how we translate to the origin. Here is our result.

Proposition 3.2.9. *For each face $Q \preceq P$, we have $V(\sigma_Q) \simeq X_Q$.*

Proof. We sketch the proof and leave the details to reader (Exercise 3.2.8). Let

$$P = \{m \in M_{\mathbb{R}} \mid \langle m, u_F \rangle \geq a_F \text{ for all facets } F \prec P\}$$

be the facet presentation of P . The facets of P containing Q also contain the origin, so that $a_F = 0$ for these facets. This implies that

$$\sigma_Q^\perp = \text{Span}(Q),$$

and then $N(\sigma_Q)$ is dual to $\text{Span}(Q) \cap M$. Note also that $N(\sigma_Q)_{\mathbb{R}} = N_{\mathbb{R}}/\text{Span}(\sigma_Q)$.

To keep track of which polytope we are using, we will write the cone (3.2.9) associated to a face $Q \preceq P$ as $\sigma_{Q,P}$. Then X_P and X_Q are given by the normal fans

$$\begin{aligned} \Sigma_P &= \{\sigma_{Q',P} \subseteq N_{\mathbb{R}} \mid Q' \prec P\} \\ \Sigma_Q &= \{\sigma_{Q',Q} \subseteq N(\sigma_{Q,P})_{\mathbb{R}} \mid Q' \prec Q\}. \end{aligned}$$

By Proposition 3.2.7, the toric variety $V(\sigma_Q) = V(\sigma_{Q,P})$ is determined by the fan

$$\begin{aligned} \text{Star}(\sigma_{Q,P}) &= \{\bar{\sigma} \mid \sigma_{Q,P} \prec \sigma \in \Sigma_P\} \\ &= \{\overline{\sigma_{Q',P}} \mid \sigma_{Q,P} \prec \sigma_{Q',P} \in \Sigma_P\} = \{\overline{\sigma_{Q',P}} \mid Q' \preceq Q\}. \end{aligned}$$

Then the proposition follows once one proves that $\overline{\sigma_{Q',P}} = \sigma_{Q',Q}$. □

Final Comments. The technique of using limit points of one-parameter subgroups to study a group action is also a major tool in Geometric Invariant Theory as in [127], where the main problem is to construct varieties (or possibly more general objects) representing orbit spaces for the actions of algebraic groups on varieties. We will apply ideas from group actions and orbit spaces to the study of toric varieties in Chapters 5 and 14.

We also note the observation made in part (d) of Theorem 3.2.6 that torus orbits have the same closure in the classical and Zariski topologies. For arbitrary subsets of a variety, these closures may differ. A torus orbit is an example of a *constructible subset*, and we will see in §3.4 that constructible subsets have the same classical and Zariski closures since we are working over \mathbb{C} .

Exercises for §3.2.

3.2.1. In this exercise, you will verify the claims made in Example 3.2.1 and the following discussion.

- (a) Show that the remaining limits of one-parameter subgroups \mathbb{P}^2 are as claimed in the example.
- (b) Show that the $(\mathbb{C}^*)^2$ -orbits in \mathbb{P}^2 are as claimed in the example.
- (c) Show that the limit point equals the distinguished point γ_σ of the corresponding cone in each case.

3.2.2. Let $\sigma \subseteq N_{\mathbb{R}}$ be a strongly convex rational polyhedral cone. This exercise will consider $\lim_{t \rightarrow 0} f(t)$, where $f : \mathbb{C}^* \rightarrow T_N$ is an arbitrary function.

- (a) Prove that $\lim_{t \rightarrow 0} f(t)$ exists in U_σ if and only if $\lim_{t \rightarrow 0} \chi^m(f(t))$ exists in \mathbb{C} for all $m \in S_\sigma$. Hint: Consider a finite set of characters \mathcal{A} such that $S_\sigma = \mathbb{N}\mathcal{A}$.
- (b) When $\lim_{t \rightarrow 0} f(t)$ exists in U_σ , prove that the limit is given by the semigroup homomorphism that maps $m \in S_\sigma$ to $\lim_{t \rightarrow 0} \chi^m(f(t))$.

3.2.3. Consider the situation of Example 3.2.3.

- (a) Show that the cones in (3.2.1) and (3.2.4) are dual.
- (b) Identify the limits of all one-parameter subgroups in this example, and describe the Orbit-Cone Correspondence in this case.
- (c) Show that the matrix

$$A = \begin{pmatrix} 1 & 1 & -1 \\ 1 & 0 & 0 \\ -1 & 0 & 1 \end{pmatrix}$$

defines an automorphism of $N \simeq \mathbb{Z}^3$ and the corresponding linear map on $N_{\mathbb{R}}$ maps the cone σ^\vee to σ .

(d) Deduce that the affine toric varieties U_σ and U_{σ^\vee} are isomorphic. Hint: Use Proposition 1.3.15.

3.2.4. Prove Lemma 3.2.4.

3.2.5. Let \mathcal{O}' be as defined in the proof of Lemma 3.2.5. In this exercise, you will complete the proof that \mathcal{O}' is a T_N -orbit in U_σ .

- (a) Show that if $\gamma \in \mathcal{O}'$, then $\widehat{\gamma} : \sigma^\perp \cap M \rightarrow \mathbb{C}^*$ is a group homomorphism.
- (b) Deduce that \mathcal{O}' has the structure of a group.
- (c) Verify carefully that we have an isomorphism of groups $\mathcal{O}' \simeq \text{Hom}_{\mathbb{Z}}(\sigma^\perp \cap M, \mathbb{C}^*)$.

3.2.6. This exercise is concerned with the proof of Theorem 3.2.6.

- (a) Let $\gamma : S_\sigma \rightarrow \mathbb{C}$ be a semigroup homomorphism giving a point of U_σ . Prove that $\{m \in S_\sigma \mid \gamma(m) \neq 0\} = \Gamma \cap M$ for some face $\Gamma \preceq \sigma^\vee$.
- (b) Show $\overline{\mathcal{O}(\tau)}$ is invariant under the action of T_N .
- (c) Prove that $\overline{\mathcal{O}(\tau)} \cap U_{\sigma'}$ is the variety of the ideal I defined in (3.2.7).

3.2.7. Let τ be a cone in a fan Σ , and let $\text{Star}(\tau)$ be as defined in (3.2.8).

- (a) Show that $\text{Star}(\tau)$ is a fan in $N(\tau)_{\mathbb{R}}$.
- (b) Prove Proposition 3.2.7.

3.2.8. Supply the details omitted in the proof of Proposition 3.2.9.

3.2.9. Consider the action of T_N on the affine toric variety U_σ . Use parts (c) and (d) of Theorem 3.2.6 to show that $\mathcal{O}(\sigma)$ is the unique closed orbit of T_N acting on U_σ .

3.2.10. In Proposition 1.3.16, we saw that if τ is a face of the strongly convex rational polyhedral cone σ in $N_{\mathbb{R}}$ then $U_\tau = \text{Spec}(\mathbb{C}[S_\tau])$ is an affine open subset of $U_\sigma = \text{Spec}(\mathbb{C}[S_\sigma])$. In this exercise, you will prove the converse, i.e., that if $\tau \subseteq \sigma$ and the induced map of affine toric varieties $\phi : U_\tau \rightarrow U_\sigma$ is an open immersion, then $\tau \preceq \sigma$, i.e., τ is a face of σ .

(a) Let $u, u' \in N \cap \sigma$, and assume $u + u' \in \tau$. Show that

$$\lim_{t \rightarrow 0} \lambda^u(t) \cdot \lim_{t \rightarrow 0} \lambda^{u'}(t) \in U_\tau.$$

- (b) Show that $\lim_{t \rightarrow 0} \lambda^u(t)$ and $\lim_{t \rightarrow 0} \lambda^{u'}(t)$ are each in U_τ . Hint: Use the description of points as semigroup homomorphisms.
- (c) Deduce that $u, u' \in \tau$, so τ is a face of σ .

3.2.11. In this exercise, you will use Proposition 3.2.2 and Theorem 3.2.6 to deduce Corollary 3.1.8 from Theorem 3.1.7.

- (a) By Theorem 3.1.7, and the results of Chapter 1, a separated toric variety has an open cover consisting of affine toric varieties $U_i = U_{\sigma_i}$ for some collection of cones σ_i . Show that for all i, j , $U_i \cap U_j$ is also affine. Hint: Use the fact that X is separated.
- (b) Show that $U_i \cap U_j$ is the affine toric variety corresponding to the cone $\tau = \sigma_i \cap \sigma_j$. Hint: Exercise 3.2.2 will be useful.
- (c) If $\tau = \sigma_i \cap \sigma_j$, then show that τ is a face of both σ_i and σ_j . Hint: Use Exercise 3.2.10.
- (d) Deduce that $X \simeq X_\Sigma$ for the fan consisting of the σ_i and all their faces.

§3.3. Toric Morphisms

Recall from §3.0 that if X and Y are varieties with affine open covers $X = \bigcup_{\alpha} U_{\alpha}$ and $Y = \bigcup_{\beta} U'_{\beta}$, then a morphism $\phi : X \rightarrow Y$ is a Zariski-continuous mapping such that the restrictions

$$\phi|_{U_{\alpha} \cap \phi^{-1}(U'_{\beta})} : U_{\alpha} \cap \phi^{-1}(U'_{\beta}) \longrightarrow U'_{\beta}$$

are morphisms in the sense of Definition 3.0.3 for all α, β .

In §1.3 we defined *toric morphisms* between affine toric varieties and studied their properties. When applied to arbitrary normal toric varieties, these results yield a class of morphisms whose construction comes directly from the combinatorics of the associated fans. The goal of this section is to study these special morphisms.

Definition 3.3.1. Let N_1, N_2 be two lattices with Σ_1 a fan in $(N_1)_{\mathbb{R}}$ and Σ_2 a fan in $(N_2)_{\mathbb{R}}$. A \mathbb{Z} -linear mapping $\bar{\phi} : N_1 \rightarrow N_2$ is **compatible** with the fans Σ_1 and Σ_2 if for every cone $\sigma_1 \in \Sigma_1$, there exists a cone $\sigma_2 \in \Sigma_2$ such that $\bar{\phi}_{\mathbb{R}}(\sigma_1) \subseteq \sigma_2$.

Example 3.3.2. Let $N_1 = \mathbb{Z}^2$ with basis e_1, e_2 and let Σ_r be the fan from Figure 4 in §3.1. By Example 3.1.16, X_{Σ_r} is the Hirzebruch surface \mathcal{H}_r . Also let $N_2 = \mathbb{Z}$ and consider the fan Σ giving \mathbb{P}^1 :

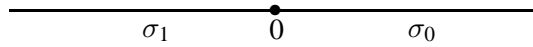

as in Example 3.1.11. The mapping

$$\bar{\phi} : N_1 \longrightarrow N_2, \quad ae_1 + be_2 \longmapsto a$$

is compatible with the fans Σ_r and Σ since each cone of Σ_r maps onto a cone of Σ . If $r \neq 0$, on the other hand, the mapping

$$\bar{\psi} : N_1 \longrightarrow N_2, \quad ae_1 + be_2 \longmapsto b$$

is not compatible with these fans since $\sigma_3 \in \Sigma_r$ does not map into a cone of Σ . \diamond

The Definition of Toric Morphism. In §1.3, we defined a toric morphism in the affine case and gave an equivalent condition in Proposition 1.3.14. For general toric varieties, it more convenient to take the result of Proposition 1.3.14 as the *definition* of toric morphism.

Definition 3.3.3. Let $X_{\Sigma_1}, X_{\Sigma_2}$ be normal toric varieties, with Σ_1 a fan in $(N_1)_{\mathbb{R}}$ and Σ_2 a fan in $(N_2)_{\mathbb{R}}$. A morphism $\phi : X_{\Sigma_1} \rightarrow X_{\Sigma_2}$ is **toric** if ϕ maps the torus $T_{N_1} \subseteq X_{\Sigma_1}$ into $T_{N_2} \subseteq X_{\Sigma_2}$ and $\phi|_{T_{N_1}}$ is a group homomorphism.

The proof of part (b) of Proposition 1.3.14 generalizes easily to show that any toric morphism $\phi : X_{\Sigma_1} \rightarrow X_{\Sigma_2}$ is an *equivariant mapping* for the T_{N_1} - and T_{N_2} -actions. That is, we have a commutative diagram

$$(3.3.1) \quad \begin{array}{ccc} T_{N_1} \times X_{\Sigma_1} & \longrightarrow & X_{\Sigma_1} \\ \phi|_{T_{N_1}} \times \phi \downarrow & & \downarrow \phi \\ T_{N_2} \times X_{\Sigma_2} & \longrightarrow & X_{\Sigma_2} \end{array}$$

where the horizontal maps give the torus actions.

Our first result shows that toric morphisms $\phi : X_{\Sigma_1} \rightarrow X_{\Sigma_2}$ correspond to \mathbb{Z} -linear mappings $\bar{\phi} : N_1 \rightarrow N_2$ that are compatible with the fans Σ_1 and Σ_2 .

Theorem 3.3.4. *Let N_1, N_2 be lattices and let Σ_i be a fan in $(N_i)_{\mathbb{R}}$, $i = 1, 2$.*

(a) *If $\bar{\phi} : N_1 \rightarrow N_2$ is a \mathbb{Z} -linear map that is compatible with Σ_1 and Σ_2 , then there is a toric morphism $\phi : X_{\Sigma_1} \rightarrow X_{\Sigma_2}$ such that $\phi|_{T_{N_1}}$ is the map*

$$\bar{\phi} \otimes 1 : N_1 \otimes_{\mathbb{Z}} \mathbb{C}^* \longrightarrow N_2 \otimes_{\mathbb{Z}} \mathbb{C}^*.$$

(b) *Conversely, if $\phi : X_{\Sigma_1} \rightarrow X_{\Sigma_2}$ is a toric morphism, then ϕ induces a \mathbb{Z} -linear map $\bar{\phi} : N_1 \rightarrow N_2$ that is compatible with the fans Σ_1 and Σ_2 .*

Proof. To prove part (a), let σ_1 be a cone in Σ_1 . Since ϕ is compatible with Σ_1 and Σ_2 , there is a cone $\sigma_2 \in \Sigma_2$ with $\bar{\phi}_{\mathbb{R}}(\sigma_1) \subseteq \sigma_2$. Then Proposition 1.3.15 shows that $\bar{\phi}$ induces a toric morphism $\phi_{\sigma_1} : U_{\sigma_1} \rightarrow U_{\sigma_2}$. Using the general criterion for gluing morphisms from Exercise 3.3.1, you will show in Exercise 3.3.2 that the ϕ_{σ_1} glue together to give a morphism $\phi : X_{\Sigma_1} \rightarrow X_{\Sigma_2}$. Moreover, ϕ is toric because taking $\sigma_1 = \{0\}$ gives $\phi_{\{0\}} : T_{N_1} \rightarrow T_{N_2}$, which is easily seen to be the group homomorphism induced by the \mathbb{Z} -linear map $\bar{\phi} : N_1 \rightarrow N_2$.

For part (b), we show first that the toric morphism ϕ induces a \mathbb{Z} -linear map $\bar{\phi} : N_1 \rightarrow N_2$. This follows since $\phi|_{T_{N_1}}$ is a group homomorphism. Hence, given $u \in N_1$, the one-parameter subgroup $\lambda^u : \mathbb{C}^* \rightarrow T_{N_1}$ can be composed with $\phi|_{T_{N_1}}$ to give the one-parameter subgroup $\phi|_{T_{N_1}} \circ \lambda^u : \mathbb{C}^* \rightarrow T_{N_2}$. This defines an element $\bar{\phi}(u) \in N_2$. It is straightforward to show that $\bar{\phi} : N_1 \rightarrow N_2$ is \mathbb{Z} -linear.

It remains to show that $\bar{\phi}$ is compatible with the fans Σ_1 and Σ_2 . Because of the equivariance (3.3.1), each T_{N_1} -orbit $O_1 \subseteq X_{\Sigma_1}$ is mapped into a T_{N_2} -orbit $O_2 \subseteq X_{\Sigma_2}$. By the Orbit-Cone Correspondence (Theorem 3.2.6), each T_{N_1} -orbit is $O_1 = O(\sigma_1)$ for some cone σ_1 in Σ_1 , and similarly each T_{N_2} -orbit is $O_2 = O(\sigma_2)$ for some cone σ_2 in Σ_2 . Furthermore, if $\tau_1 \preceq \sigma_1$ is a face, then by the same reasoning, there is some cone τ_2 in Σ_2 such that $\phi(O(\tau_1)) \subseteq O(\tau_2)$.

We claim that in this situation τ_2 must be a face of σ_2 . This follows since $O(\sigma) \subseteq \overline{O(\tau)}$ by part (d) of Theorem 3.2.6. Since ϕ is continuous in the Zariski topology, $\phi(\overline{O(\tau_1)}) \subseteq \overline{O(\tau_2)}$. But the only orbits contained in the closure of $O(\tau_2)$

are the orbits corresponding to cones which have τ_2 as a face. So τ_2 is a face of σ_2 . It follows from part (c) of Theorem 3.2.6 that ϕ also maps the affine open subset $U_{\sigma_1} \subseteq X_{\Sigma_1}$ into $U_{\sigma_2} \subseteq X_{\Sigma_2}$, i.e.,

$$(3.3.2) \quad \phi(U_{\sigma_1}) \subseteq U_{\sigma_2}.$$

Hence ϕ induces a toric morphism $U_{\sigma_1} \rightarrow U_{\sigma_2}$, which by Proposition 1.3.15 implies that $\overline{\phi}_{\mathbb{R}}(\sigma_1) \subseteq \sigma_2$. Hence $\overline{\phi}$ is compatible with the fans Σ_1 and Σ_2 . \square

First Examples. Here are some examples of toric morphisms defined by mappings compatible with the corresponding fans.

Example 3.3.5. Let $N_1 = \mathbb{Z}^2$ and $N_2 = \mathbb{Z}$, and let

$$\overline{\phi} : N_1 \longrightarrow N_2, \quad ae_1 + be_2 \longmapsto a,$$

be the first mapping in Example 3.3.2. We saw that $\overline{\phi}$ is compatible with the fans Σ_r of the Hirzebruch surface \mathcal{H}_r and Σ of \mathbb{P}^1 . Theorem 3.3.4 implies that there is a corresponding toric morphism $\phi : \mathcal{H}_r \rightarrow \mathbb{P}^1$. We will see later in the section that this mapping gives \mathcal{H}_r the structure of a \mathbb{P}^1 -bundle over \mathbb{P}^1 . \diamond

Example 3.3.6. Let $N = \mathbb{Z}^n$ and Σ be a fan in $N_{\mathbb{R}}$. For $\ell \in \mathbb{Z}_{>0}$, the multiplication map

$$\overline{\phi}_{\ell} : N \longrightarrow N, \quad a \longmapsto \ell \cdot a$$

is compatible with Σ . By Theorem 3.3.4, there is a corresponding toric morphism $\phi_{\ell} : X_{\Sigma} \rightarrow X_{\Sigma}$ whose restriction to $T_N \subseteq X_{\Sigma}$ is the group endomorphism

$$\phi_{\ell}|_{T_N}(t_1, \dots, t_n) = (t_1^{\ell}, \dots, t_n^{\ell}).$$

For a concrete example, let Σ be the fan in $N_{\mathbb{R}} = \mathbb{R}^2$ from Figure 2 and take $\ell = 2$. Then we obtain the morphism $\phi_2 : \mathbb{P}^2 \rightarrow \mathbb{P}^2$ defined in homogeneous coordinates by $\phi_2(x_0, x_1, x_2) = (x_0^2, x_1^2, x_2^2)$. We will use ϕ_{ℓ} in Chapter 9. \diamond

Sublattices of Finite Index. We get an interesting toric morphism when a lattice N' has finite index in a larger lattice N . If Σ is a fan in $N_{\mathbb{R}}$, then we can view Σ as a fan either in $N'_{\mathbb{R}}$ or in $N_{\mathbb{R}}$, and the inclusion $N' \hookrightarrow N$ is compatible with the fan Σ in $N'_{\mathbb{R}}$ and $N_{\mathbb{R}}$. As in Chapter 1, we obtain toric varieties $X_{\Sigma, N'}$ and $X_{\Sigma, N}$ depending on which lattice we consider, and the inclusion $N' \hookrightarrow N$ induces a toric morphism

$$\phi : X_{\Sigma, N'} \longrightarrow X_{\Sigma, N}.$$

Proposition 3.3.7. *Let N' be a sublattice of finite index in N and let Σ be a fan in $N_{\mathbb{R}} = N'_{\mathbb{R}}$. Let $G = N/N'$. Then*

$$\phi : X_{\Sigma, N'} \longrightarrow X_{\Sigma, N}$$

induced by the inclusion $N' \hookrightarrow N$ presents $X_{\Sigma, N}$ as the quotient $X_{\Sigma, N'}/G$.

Proof. Since N' has finite index in N , Proposition 1.3.18 shows that the finite group $G = N/N'$ is the kernel of $T_{N'} \rightarrow T_N$. It follows that G acts on $X_{\Sigma, N'}$. This action is compatible with the inclusion $U_{\sigma, N'} \subseteq X_{\Sigma, N'}$ for each cone $\sigma \in \Sigma$. Using Proposition 1.3.18 again, we see that $U_{\sigma, N'}/G \simeq U_{\sigma, N}$, which easily implies that $X_{\Sigma, N'}/G \simeq X_{\Sigma, N}$. \square

We will revisit Proposition 3.3.7 in Chapter 5, where we will show that the map $\phi : X_{\Sigma, N'} \rightarrow X_{\Sigma, N}$ is a *geometric quotient*.

Example 3.3.8. Let $N = \mathbb{Z}^2$, and Σ be the fan shown in Figure 5, so $X_{\Sigma, N}$ gives the weighted projective space $\mathbb{P}(1, 1, 2)$. Let N' be the sublattice of N given by $N' = \{(a, b) \in N \mid b \equiv 0 \pmod{2}\}$, so N' has index 2 in N . Note that N' is generated by $u_1 = e_1$, $u_2 = 2e_2$ and that

$$u_0 = -e_1 - 2e_2 = -u_1 - u_2 \in N'.$$

Let $\bar{\phi} : N' \hookrightarrow N$ be the inclusion map. It is not difficult to see that with respect to the lattice N' , $X_{\Sigma, N'} \simeq \mathbb{P}^2$ (Exercise 3.3.3). By Theorem 3.3.4, the \mathbb{Z} -linear map $\bar{\phi}$ induces a toric morphism $\phi : \mathbb{P}^2 \rightarrow \mathbb{P}(1, 1, 2)$, and by Proposition 3.3.7, it follows that $\mathbb{P}(1, 1, 2) \simeq \mathbb{P}^2/G$ for $G = N/N' \simeq \mathbb{Z}/2\mathbb{Z}$.

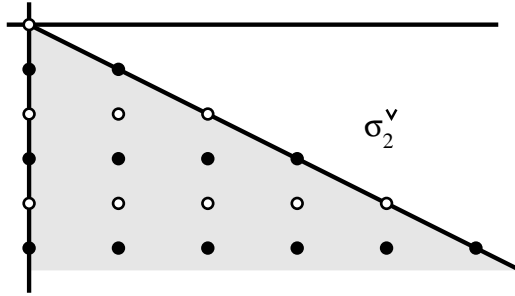

Figure 8. The semigroups $\sigma_2^\vee \cap M$ and $\sigma_2^\vee \cap M'$

The cone σ_2 from Figure 5 has the dual cone σ_2^\vee shown in Figure 8. It is instructive to consider how σ_2^\vee interacts with the lattice M' dual to N' . One checks that $M' \simeq \{(a, b/2) : a, b \in \mathbb{Z}\}$ and $\sigma_2^\vee = \text{Cone}(2e_1 - e_2, -e_2)$. In Figure 8, the points in $\sigma_2^\vee \cap M$ are shown in white, and the points in $\sigma_2^\vee \cap M'$ not in $\sigma_2^\vee \cap M$ are shown in black. Note that the picture in $\sigma_2^\vee \cap M$ is the same (up to a change of coordinates in $\text{GL}(2, \mathbb{Z})$) as Figure 10 from Chapter 1. This shows again that $\mathbb{P}(1, 1, 2)$ contains the affine open subset $U_{\sigma_2, N}$ isomorphic to the rational normal cone \widehat{C}_2 . On the other hand $U_{\sigma_2, N'} \simeq \mathbb{C}^2$ is smooth. The other affine open subsets corresponding to σ_1 and σ_0 are isomorphic to \mathbb{C}^2 in both \mathbb{P}^2 and in $\mathbb{P}(1, 1, 2)$. \diamond

Torus Factors. A toric variety X_Σ has a *torus factor* if it is equivariantly isomorphic to the product of a nontrivial torus and a toric variety of smaller dimension.

Proposition 3.3.9. *Let X_Σ be the toric variety of the fan Σ . Then the following are equivalent:*

- (a) X_Σ has a torus factor.
- (b) There is a nonconstant morphism $X_\Sigma \rightarrow \mathbb{C}^*$.
- (c) The u_ρ , $\rho \in \Sigma(1)$, do not span $N_{\mathbb{R}}$.

Recall that $\Sigma(1)$ consists of the 1-dimensional cones of Σ , i.e., its rays, and that u_ρ is the minimal generator of a ray $\rho \in \Sigma(1)$.

Proof. If $X_\Sigma \simeq X_{\Sigma'} \times (\mathbb{C}^*)^r$ for $r > 0$ and some toric variety $X_{\Sigma'}$, then a nontrivial character of $(\mathbb{C}^*)^r$ gives a nonconstant morphism $X_\Sigma \rightarrow (\mathbb{C}^*)^r \rightarrow \mathbb{C}^*$.

If $\phi : X_\Sigma \rightarrow \mathbb{C}^*$ is a nonconstant morphism, then Exercise 3.3.4 implies that the restriction of ϕ to T_N is $c\chi^m$ where $c \in \mathbb{C}^*$ and $m \in M$. Multiplying by c^{-1} , we may assume that $\phi|_{T_N} = \chi^m$. Then ϕ is a toric morphism coming from a surjective homomorphism $\bar{\phi} : N \rightarrow \mathbb{Z}$. Since \mathbb{C}^* comes from the trivial fan, ϕ maps all cones of Σ to the origin. Hence $u_\rho \in \ker(\bar{\phi})$ for all $\rho \in \Sigma(1)$, so the u_ρ do not span $N_{\mathbb{R}}$.

Finally, suppose that the u_ρ , $\rho \in \Sigma(1)$ span a proper subspace of $N_{\mathbb{R}}$. Then $N' = \text{Span}(u_\rho \mid \rho \in \Sigma(1)) \cap N$ is proper sublattice of N such that N/N' is torsion-free, so N' has a complement N'' with $N = N' \times N''$. Furthermore, Σ can be regarded as a fan Σ' in $N'_{\mathbb{R}}$, and then Σ is the product fan $\Sigma = \Sigma' \times \Sigma''$, where Σ'' is the trivial fan in $N''_{\mathbb{R}}$. Then Proposition 3.1.14 gives an isomorphism

$$X_\Sigma \simeq X_{\Sigma', N'} \times T_{N''} \simeq X_{\Sigma', N'} \times (\mathbb{C}^*)^{n-k},$$

where $\dim N_{\mathbb{R}} = n$ and $\dim N'_{\mathbb{R}} = k$. □

In later chapters, torus varieties *without* torus factors will play an important role. Hence we state the following corollary of Proposition 3.3.9.

Corollary 3.3.10. *Let X_Σ be the toric variety of the fan Σ . Then the following are equivalent:*

- (a) X_Σ has no torus factors.
- (b) Every morphism $X_\Sigma \rightarrow \mathbb{C}^*$ is constant, i.e., $\Gamma(X_\Sigma, \mathcal{O}_{X_\Sigma})^* = \mathbb{C}^*$.
- (c) The u_ρ , $\rho \in \Sigma(1)$, span $N_{\mathbb{R}}$. □

We can also think about torus factors from the point of view of sublattices.

Proposition 3.3.11. *Let $N' \subseteq N$ be a sublattice with $\dim N_{\mathbb{R}} = n$, $\dim N'_{\mathbb{R}} = k$. Let Σ be a fan in $N'_{\mathbb{R}}$, which we can regard as a fan in $N_{\mathbb{R}}$.*

- (a) *If N' is spanned by a subset of a basis of N , then we have an isomorphism*

$$\phi : X_{\Sigma, N} \simeq X_{\Sigma, N'} \times T_{N/N'} \simeq X_{\Sigma, N'} \times (\mathbb{C}^*)^{n-k}.$$

(b) In general, a basis for N' can be extended to a basis of a sublattice $N'' \subseteq N$ of finite index. Then $X_{\Sigma, N}$ is isomorphic to the quotient of

$$X_{\Sigma, N''} \simeq X_{\Sigma, N'} \times T_{N''/N'} \simeq X_{\Sigma, N'} \times (\mathbb{C}^*)^{n-k}$$

by the finite abelian group N/N'' .

Proof. Part (a) follows from the proof of Proposition 3.3.9, and part (b) follows from part (a) and Proposition 3.3.7. \square

Refinements of Fans and Blowups. Given a fan Σ in $N_{\mathbb{R}}$, a fan Σ' *refines* Σ if every cone of Σ' is contained in a cone of Σ and $|\Sigma'| = |\Sigma|$. Hence every cone of Σ is a union of cones of Σ' . When Σ' refines Σ , the identity mapping on N is clearly compatible with Σ' and Σ . This yields a toric morphism $\phi : X_{\Sigma'} \rightarrow X_{\Sigma}$.

Example 3.3.12. Consider the fan Σ' in $N \simeq \mathbb{Z}^2$ pictured in Figure 1 from §3.1. This is a refinement of the fan Σ consisting of $\text{Cone}(e_1, e_2)$ and its faces. The corresponding toric varieties are $X_{\Sigma} \simeq \mathbb{C}^2$ and $X_{\Sigma'} \simeq W = \mathbf{V}(x_0y - x_1x) \subseteq \mathbb{P}^1 \times \mathbb{C}^2$, the blowup of \mathbb{C}^2 at the origin (see Example 3.1.15). The identity map on N induces a toric morphism $\phi : W \rightarrow \mathbb{C}^2$. This “blowdown” morphism maps $\mathbb{P}^1 \times \{0\} \subseteq W$ to $0 \in \mathbb{C}^2$ and is injective outside of $\mathbb{P}^1 \times \{0\}$ in W . \diamond

We can generalize this example and Example 3.1.5 as follows.

Definition 3.3.13. Let Σ be a fan in $N_{\mathbb{R}} \simeq \mathbb{R}^n$. Let $\sigma = \text{Cone}(u_1, \dots, u_n)$ be a smooth cone in Σ , so that u_1, \dots, u_n is a basis for N . Let $u_0 = u_1 + \dots + u_n$ and let $\Sigma'(\sigma)$ be the set of all cones generated by subsets of $\{u_0, \dots, u_n\}$ not containing $\{u_1, \dots, u_n\}$. Then

$$\Sigma^*(\sigma) = (\Sigma \setminus \{\sigma\}) \cup \Sigma'(\sigma)$$

is a fan in $N_{\mathbb{R}}$ called the *star subdivision* of Σ along σ .

Example 3.3.14. Let $\sigma = \text{Cone}(u_1, u_2, u_3) \subseteq N_{\mathbb{R}} \simeq \mathbb{R}^3$ be a smooth cone. Figure 9 on the next page shows the star subdivision of σ into three cones

$$\text{Cone}(u_0, u_1, u_2), \text{Cone}(u_0, u_1, u_3), \text{Cone}(u_0, u_2, u_3).$$

The fan $\Sigma^*(\sigma)$ consists of these cones, together with their faces. \diamond

Proposition 3.3.15. $\Sigma^*(\sigma)$ is a refinement of Σ , and the induced toric morphism

$$\phi : X_{\Sigma^*(\sigma)} \longrightarrow X_{\Sigma}$$

makes $X_{\Sigma^*(\sigma)}$ the blowup of X_{Σ} at the distinguished point γ_{σ} corresponding to the cone σ .

Proof. Since Σ and $\Sigma^*(\sigma)$ are the same outside the cone σ , without loss of generality, we may reduce to the case that Σ is the fan consisting of σ and all of its faces, and X_{Σ} is the affine toric variety $U_{\sigma} \simeq \mathbb{C}^n$.

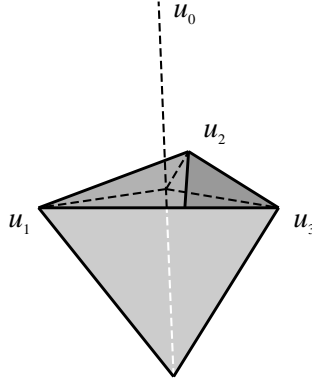

Figure 9. The star subdivision $\Sigma^*(\sigma)$

Under the Orbit-Cone Correspondence (Theorem 3.2.6), σ corresponds to the distinguished point γ_σ , the origin (the unique fixed point of the torus action). By Theorem 3.3.4, the identity map on N induces a toric morphism

$$\phi : X_{\Sigma^*(\sigma)} \rightarrow U_\sigma \simeq \mathbb{C}^n.$$

It is easy to check that the affine open sets covering $X_{\Sigma^*(\sigma)}$ are the same as for the blowup of \mathbb{C}^n at the origin from Exercise 3.0.8, and they are glued together in the same way by Exercise 3.1.5. \square

The blowup X_Σ at γ_σ is sometimes denoted $\text{Bl}_{\gamma_\sigma}(X_\Sigma)$. In this notation, the blowup of \mathbb{C}^n at the origin is written $\text{Bl}_0(\mathbb{C}^n)$.

The point blown up in Proposition 3.3.15 is a fixed point of the torus action. In some cases, torus-invariant subvarieties of larger dimension have equally nice blowups. We begin with the affine case. The standard basis e_1, \dots, e_n of \mathbb{Z}^n gives $\sigma = \text{Cone}(e_1, \dots, e_n)$ with $U_\sigma = \mathbb{C}^n$, and the face $\tau = \text{Cone}(e_1, \dots, e_r)$, $2 \leq r \leq n$, gives the orbit closure

$$V(\tau) = \overline{O(\tau)} = \{0\} \times \mathbb{C}^{n-r}.$$

To construct the blowup of $V(\tau)$, let $u_0 = u_1 + \dots + u_r$ and consider the fan

$$(3.3.3) \quad \Sigma^*(\tau) = \{\text{Cone}(A) \mid A \subseteq \{u_0, \dots, u_n\}, \{u_1, \dots, u_r\} \not\subseteq A\}.$$

Example 3.3.16. Let $\sigma = \text{Cone}(e_1, e_2, e_3) \subseteq N_{\mathbb{R}} \simeq \mathbb{R}^3$ and $\tau = \text{Cone}(e_1, e_2)$. The star subdivision relative to τ subdivides σ into the cones

$$\text{Cone}(e_0, e_1, e_3), \text{Cone}(e_0, e_2, e_3),$$

as shown in Figure 10 on the next page. The fan $\Sigma^*(\tau)$ consists of these two cones, together with their faces. \diamond

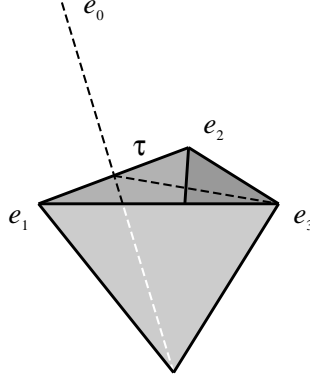

Figure 10. The star subdivision $\Sigma^*(\tau)$

For the fan (3.3.3), the toric variety $X_{\Sigma^*(\tau)}$ is the blowup of $\{0\} \times \mathbb{C}^{n-r} \subseteq \mathbb{C}^n$. To see why, observe that $\Sigma^*(\tau)$ is a product fan. Namely, $\mathbb{Z}^n = \mathbb{Z}^r \times \mathbb{Z}^{n-r}$, and

$$\Sigma^*(\tau) = \Sigma_1 \times \Sigma_2,$$

where Σ_1 is the fan for $\text{Bl}_0(\mathbb{C}^r)$ (coming from a refinement of $\text{Cone}(u_1, \dots, u_r)$) and Σ_2 is the fan for \mathbb{C}^{n-r} (coming from $\text{Cone}(u_{r+1}, \dots, u_n)$). It follows that

$$X_{\Sigma^*(\tau)} = \text{Bl}_0(\mathbb{C}^r) \times \mathbb{C}^{n-r}.$$

Since $\text{Bl}_0(\mathbb{C}^r)$ is built by replacing $0 \in \mathbb{C}^r$ with \mathbb{P}^{r-1} , it follows that $X_{\Sigma^*(\tau)} = \text{Bl}_0(\mathbb{C}^r) \times \mathbb{C}^{n-r}$ is built by replacing $\{0\} \times \mathbb{C}^{n-r} \subseteq \mathbb{C}^n$ with $\mathbb{P}^{r-1} \times \mathbb{C}^{n-r}$. The intuitive idea is that $\text{Bl}_0(\mathbb{C}^r)$ separates directions through the origin in \mathbb{C}^r , while the blowup $\text{Bl}_{\{0\} \times \mathbb{C}^{n-r}}(\mathbb{C}^n) = X_{\Sigma^*(\tau)}$ separates *normal* directions to $\{0\} \times \mathbb{C}^{n-r}$ in \mathbb{C}^n . One can also study $\text{Bl}_{\{0\} \times \mathbb{C}^{n-r}}(\mathbb{C}^n)$ by working on affine pieces given by the maximal cones of $\Sigma^*(\tau)$ —see [134, Prop. 1.26].

We generalize (3.3.3) as follows.

Definition 3.3.17. Let Σ be a fan in $N_{\mathbb{R}} \simeq \mathbb{R}^n$ and assume $\tau \in \Sigma$ has the property that all cones of Σ containing τ are smooth. Let $u_\tau = \sum_{\rho \in \tau(1)} u_\rho$ and for each cone $\sigma \in \Sigma$ containing τ , set

$$\Sigma_\sigma^*(\tau) = \{\text{Cone}(A) \mid A \subseteq \{u_\tau\} \cup \sigma(1), \tau(1) \not\subseteq A\}.$$

Then the *star subdivision* of Σ relative to τ is the fan

$$\Sigma^*(\tau) = \{\sigma \in \Sigma \mid \tau \not\subseteq \sigma\} \cup \bigcup_{\tau \subseteq \sigma} \Sigma_\sigma^*(\tau).$$

The fan $\Sigma^*(\tau)$ is a refinement of Σ and hence induces a toric morphism

$$\phi : X_{\Sigma^*(\tau)} \rightarrow X_\Sigma.$$

Under the map ϕ , $X_{\Sigma^*(\tau)}$ becomes the blowup $\text{Bl}_{V(\tau)}(X_\Sigma)$ of X_Σ along the orbit closure $V(\tau)$.

In Chapters 10 and 11 we will use toric morphisms coming from a generalized version of star subdivision to resolve the singularities of toric varieties.

Exact Sequences and Fibrations. Next, we consider a class of toric morphisms that have a nice local structure. To begin, consider a surjective \mathbb{Z} -linear mapping

$$\bar{\phi} : N \rightarrow N'.$$

If Σ in $N_{\mathbb{R}}$ and Σ' in $N'_{\mathbb{R}}$ are compatible with $\bar{\phi}$, then we have a corresponding toric morphism

$$\phi : X_\Sigma \rightarrow X_{\Sigma'}.$$

Now let $N_0 = \ker(\bar{\phi})$, so that we have an exact sequence

$$(3.3.4) \quad 0 \longrightarrow N_0 \longrightarrow N \xrightarrow{\bar{\phi}} N' \longrightarrow 0.$$

It is easy to check that

$$\Sigma_0 = \{\sigma \in \Sigma \mid \sigma \subseteq (N_0)_{\mathbb{R}}\}$$

is a subfan of Σ whose cones lie in $(N_0)_{\mathbb{R}} \subseteq N_{\mathbb{R}}$. By Proposition 3.3.11,

$$(3.3.5) \quad X_{\Sigma_0, N} \simeq X_{\Sigma_0, N_0} \times T_{N'}$$

since $N/N_0 \simeq N'$. Furthermore, $\bar{\phi}$ is compatible with Σ_0 in $N_{\mathbb{R}}$ and the trivial fan $\{0\}$ in $N'_{\mathbb{R}}$. This gives the toric morphism

$$\phi|_{X_{\Sigma_0, N}} : X_{\Sigma_0, N} \rightarrow T_{N'}.$$

In fact, by the reasoning to prove Proposition 3.3.4,

$$(3.3.6) \quad \phi^{-1}(T_{N'}) = X_{\Sigma_0, N} \simeq X_{\Sigma_0, N_0} \times T_{N'}.$$

In other words, the part of X_Σ lying over $T_{N'} \subseteq X_{\Sigma'}$ is identified with the product of $T_{N'}$ and the toric variety X_{Σ_0, N_0} . We say this subset of X_Σ is a *fiber bundle* over $T_{N'}$ with fiber X_{Σ_0, N_0} .

When the fan Σ has a suitable structure relative to $\bar{\phi}$, we can make a similar statement for every torus-invariant affine open subset of $X_{\Sigma'}$.

Definition 3.3.18. In the situation of (3.3.4), we say Σ is *split by* Σ' and Σ_0 if there exists a subfan $\widehat{\Sigma} \subseteq \Sigma$ such that:

- (a) $\bar{\phi}_{\mathbb{R}}$ maps each cone $\widehat{\sigma} \in \widehat{\Sigma}$ bijectively to a cone $\sigma' \in \Sigma'$ such that $\widehat{\sigma} \mapsto \sigma'$ defines a bijection $\widehat{\Sigma} \rightarrow \Sigma'$.
- (b) Given cones $\widehat{\sigma} \in \widehat{\Sigma}$ and $\sigma_0 \in \Sigma_0$, the sum $\widehat{\sigma} + \sigma_0$ lies in Σ , and every cone of Σ arises this way.

Theorem 3.3.19. *If Σ is split by Σ' and Σ_0 as in Definition 3.3.18, then X_Σ is a locally trivial fiber bundle over $X_{\Sigma'}$ with fiber X_{Σ_0, N_0} , i.e., $X_{\Sigma'}$ has a cover by affine open subsets U satisfying*

$$\phi^{-1}(U) \simeq X_{\Sigma_0, N_0} \times U.$$

Proof. Fix σ' in Σ' and let $\Sigma(\sigma') = \{\sigma \in \Sigma \mid \bar{\phi}(\sigma) \subseteq \sigma'\}$. Then

$$\phi^{-1}(U_{\sigma'}) = X_{\Sigma(\sigma')}.$$

It remains to show that $X_{\Sigma(\sigma')} \simeq X_{\Sigma_0, N_0} \times U_{\sigma'}$. Since $\Sigma(\sigma')$ is split by $\Sigma_0 \cap \Sigma(\sigma')$ and $\widehat{\Sigma} \cap \Sigma(\sigma')$, we may assume $X_{\Sigma'} = U_{\sigma'}$. In other words, we are reduced to the case when Σ' consists of σ' and its proper faces.

A \mathbb{Z} -linear map $\bar{\nu} : N' \rightarrow N$ splits the exact sequence (3.3.4) provided $\bar{\phi} \circ \bar{\nu}$ is the identity on N' . A splitting induces an isomorphism

$$N_0 \times N' \simeq N.$$

By Definition 3.3.18, there is a cone $\widehat{\sigma} \in \widehat{\Sigma}$ such that $\bar{\phi}_{\mathbb{R}}$ maps $\widehat{\sigma}$ bijectively to σ' . Using $\widehat{\sigma}$, one can find a splitting $\bar{\nu}$ with the property that $\bar{\nu}_{\mathbb{R}}$ maps τ' to $\widehat{\tau}$ for all $\widehat{\tau} \in \widehat{\Sigma}$ (Exercise 3.3.5). Using Definition 3.3.18 again, we see that

$$(N_0)_{\mathbb{R}} \times N'_{\mathbb{R}} \simeq N_{\mathbb{R}}$$

carries the product fan $(\Sigma_0, (N_0)_{\mathbb{R}}) \times (\Sigma', N'_{\mathbb{R}})$ to the fan $(\Sigma, N_{\mathbb{R}})$. By Proposition 3.1.14, we conclude that

$$X_\Sigma \simeq X_{\Sigma_0, N_0} \times X_{\Sigma'} \simeq X_{\Sigma_0, N_0} \times U_{\sigma'},$$

and the theorem is proved. \square

Example 3.3.20. To complete the discussion from Examples 3.3.2 and 3.3.5, consider the toric morphism $\phi : \mathcal{H}_r \rightarrow \mathbb{P}^1$ induced by the mapping

$$\bar{\phi} : \mathbb{Z}^2 \longrightarrow \mathbb{Z}, \quad ae_1 + be_2 \longmapsto a.$$

The fan Σ_r of \mathcal{H}_r is split by the fan of \mathbb{P}^1 and $\Sigma_0 = \{\sigma \in \Sigma_r \mid \bar{\phi}_{\mathbb{R}}(\sigma) = \{0\}\}$ because of the subfan $\widehat{\Sigma}$ of Σ_r consisting of the cones

$$\text{Cone}(-e_1 + re_2), \{0\}, \text{Cone}(e_1).$$

These cones are mapped bijectively to the cones in Σ' under $\bar{\phi}_{\mathbb{R}}$. Note also that Σ_0 consists of the cones

$$\text{Cone}(e_2), \{0\}, \text{Cone}(-e_2).$$

The fans $\widehat{\Sigma}$ and Σ_0 are shown in Figure 11 on the next page.

As we vary over all $\widehat{\sigma} \in \widehat{\Sigma}$ and $\sigma_0 \in \Sigma_0$, the sums $\widehat{\sigma} + \sigma_0$ give all cones of \mathcal{H}_r . Hence Theorem 3.3.19 shows that \mathcal{H}_r is a locally trivial fibration over \mathbb{P}^1 , with fibers isomorphic to

$$X_{\Sigma_0, N_0} \simeq \mathbb{P}^1,$$

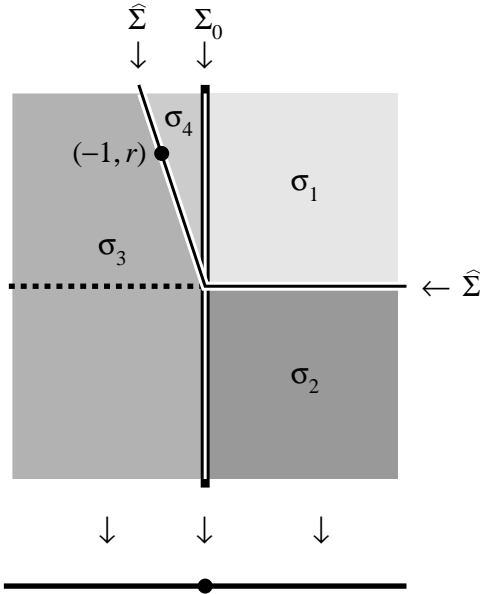

Figure 11. The Splitting of the Fan Σ_r

where $N_0 = \ker(\bar{\phi})$ gives the vertical axis in Figure 11. This fibration is not globally trivial when $r > 0$, i.e., it is not true that $\mathcal{H}_r \simeq \mathbb{P}^1 \times \mathbb{P}^1$. There is some “twisting” on the fibers involved when we try to glue together the $\phi^{-1}(U_{\sigma'}) \simeq U_{\sigma'} \times \mathbb{P}^1$ to obtain \mathcal{H}_r . \diamond

We will give another, more precise, description of these fiber bundles and the “twisting” mentioned above using the language of sheaves in Chapter 7.

Images of Distinguished Points. Each orbit $O(\sigma)$ in a toric variety X_Σ contains a distinguished point γ_σ , and each orbit closure $V(\sigma)$ is a toric variety in its own right. These structures are compatible with toric morphisms as follows.

Lemma 3.3.21. *Let $\phi : X_\Sigma \rightarrow X_{\Sigma'}$ be the toric morphism coming from a map $\bar{\phi} : N \rightarrow N'$ that is compatible with Σ and Σ' . Given $\sigma \in \Sigma$, let $\sigma' \in \Sigma'$ be the minimal cone of Σ' containing $\bar{\phi}_\mathbb{R}(\sigma)$. Then:*

- (a) $\phi(\gamma_\sigma) = \gamma_{\sigma'}$, where $\gamma_\sigma \in O(\sigma)$ and $\gamma_{\sigma'} \in O(\sigma')$ are the distinguished points.
- (b) $\phi(O(\sigma)) \subseteq O(\sigma')$ and $\phi(V(\sigma)) \subseteq V(\sigma')$.
- (c) The induced map $\phi|_{V(\sigma)} : V(\sigma) \rightarrow V(\sigma')$ is a toric morphism.

Proof. First observe that if $\sigma'_1, \sigma'_2 \in \Sigma'$ contain $\bar{\phi}_\mathbb{R}(\sigma)$, then so does their intersection. Hence Σ' has a minimal cone containing $\bar{\phi}_\mathbb{R}(\sigma)$.

To prove part (a), pick $u \in \text{Relint}(\sigma)$ and observe that $\overline{\phi}(u) \in \text{Relint}(\sigma')$ by the minimality of σ' . Then

$$\phi(\gamma_\sigma) = \phi(\lim_{t \rightarrow 0} \lambda^u(t)) = \lim_{t \rightarrow 0} \phi(\lambda^u(t)) = \lim_{t \rightarrow 0} \lambda^{\overline{\phi}(u)}(t) = \gamma_{\sigma'},$$

where the first and last equalities use Proposition 3.2.2.

The first assertion of part (b) follows immediately from part (a) by the equivariance, and the second assertion follows by continuity (as usual, we get the same closure in the classical and Zariski topologies).

For (c), observe that $\phi|_{\mathcal{O}(\sigma)} : \mathcal{O}(\sigma) \rightarrow \mathcal{O}(\sigma')$ is a morphism that is also a group homomorphism—this follows easily from equivariance. Since the orbit closures are toric varieties by Proposition 3.2.7, the map $\phi|_{V(\sigma)} : V(\sigma) \rightarrow V(\sigma')$ is a toric morphism according to Definition 3.3.3. \square

Exercises for §3.3.

3.3.1. Let X be a variety with an affine open cover $\{U_i\}$, and let Y be a second variety. Let $\phi_i : U_i \rightarrow Y$ be a collection of morphisms. We say that a morphism $\phi : X \rightarrow Y$ is obtained by gluing the ϕ_i if $\phi|_{U_i} = \phi_i$ for all i . Show that there exists such a $\phi : X \rightarrow Y$ if and only if for every pair i, j ,

$$\phi_i|_{U_i \cap U_j} = \phi_j|_{U_i \cap U_j}.$$

3.3.2. Let N_1, N_2 be lattices, and let Σ_1 in $(N_1)_{\mathbb{R}}$, Σ_2 in $(N_2)_{\mathbb{R}}$ be fans. Let $\overline{\phi} : N_1 \rightarrow N_2$ be a \mathbb{Z} -linear mapping that is compatible with the corresponding fans. Using Exercise 3.3.1 above, show that the toric morphisms $\phi_{\sigma_1} : U_{\sigma_1} \rightarrow U_{\sigma_2}$ constructed in the proof of Theorem 3.3.4 glue together to form a morphism $\phi : X_{\Sigma_1} \rightarrow X_{\Sigma_2}$.

3.3.3. This exercise asks you to verify some of the claims made in Example 3.3.8.

- (a) Verify that $X_{\Sigma, N'} \simeq \mathbb{P}^2$ with respect to the lattice N' .
- (b) Verify carefully that the affine open subset $U_{\sigma_2, N} \simeq \widehat{C}_2$, where \widehat{C}_2 is the rational normal cone \widehat{C}_d with $d = 2$.

3.3.4. A character χ^m , $m \in M$, gives a morphism $T_N \rightarrow \mathbb{C}^*$. Here you will determine *all* morphisms $T_N \rightarrow \mathbb{C}^*$.

- (a) Explain why morphisms $T_N \rightarrow \mathbb{C}^*$ correspond to invertible elements in the coordinate ring of T_N .
- (b) Let $c \in \mathbb{C}^*$ and $\alpha \in \mathbb{Z}^n$. Prove that ct^α is invertible in $\mathbb{C}[t_1^{\pm 1}, \dots, t_n^{\pm 1}]$ and that all invertible elements of $\mathbb{C}[t_1^{\pm 1}, \dots, t_n^{\pm 1}]$ are of this form.
- (c) Use part (a) to show that all morphisms $T_N \rightarrow \mathbb{C}^*$ on T_N are of the form $c\chi^m$ for $c \in \mathbb{C}^*$ and $m \in M$.

3.3.5. Let $\overline{\phi} : N \rightarrow N'$ be a surjective \mathbb{Z} -linear mapping and let $\widehat{\sigma}$ and σ' be cones in $N_{\mathbb{R}}$ and $N'_{\mathbb{R}}$ respectively with the property that $\overline{\phi}_{\mathbb{R}}$ maps $\widehat{\sigma}$ bijectively onto σ' . Prove that $\overline{\phi}$ has a splitting $\overline{\nu} : N' \rightarrow N$ such that $\overline{\nu}$ maps σ' to $\widehat{\sigma}$.

3.3.6. Let Σ' be the fan obtained from the fan Σ for \mathbb{P}^2 in Example 3.1.9 by the following process. Subdivide the cone σ_2 into two new cones σ_{21} and σ_{22} by inserting an edge $\text{Cone}(-e_2)$.

- (a) Show that the resulting toric variety $X_{\Sigma'}$ is smooth.
- (b) Show that $X_{\Sigma'}$ is the blowup of \mathbb{P}^2 at the point $V(\sigma_2)$.
- (c) Show that $X_{\Sigma'}$ is isomorphic to the Hirzebruch surface \mathcal{H}_1 .

3.3.7. Let X_{Σ} be the toric variety obtained from \mathbb{P}^2 by blowing up the points $V(\sigma_1)$ and $V(\sigma_2)$ (see Figure 2 in Example 3.1.9). Show that X_{Σ} is isomorphic to the blowup of $\mathbb{P}^1 \times \mathbb{P}^1$ at the point $V(\sigma_{11})$ (see Figure 3 in Example 3.1.12).

3.3.8. Let Σ' be the fan obtained from the fan Σ for $\mathbb{P}(1, 1, 2)$ in Example 3.1.17 by the following process. Subdivide the cone σ_2 into two new cones σ_{21} and σ_{22} by inserting an edge $\text{Cone}(-u_2)$.

- (a) Show that the resulting toric variety $X_{\Sigma'}$ is smooth.
- (b) Construct a morphism $\phi : X_{\Sigma'} \rightarrow X_{\Sigma}$ and determine the fiber over the unique singular point of X_{Σ} .
- (c) One of our smooth examples is isomorphic to $X_{\Sigma'}$. Which one is it?

3.3.9. Consider the action of the group $G = \{(\zeta, \zeta^3) \mid \zeta^5 = 1\} \subseteq (\mathbb{C}^*)^2$ on \mathbb{C}^2 . We will study the quotient \mathbb{C}^2/G and its resolution of singularities using toric morphisms.

- (a) Let $N' = \mathbb{Z}^2$ and $N = \{(a/5, b/5) \mid a, b \in \mathbb{Z}, b \equiv 3a \pmod{5}\}$. Also let $\zeta_5 = e^{2\pi i/5}$. Prove that the map $N \rightarrow (\mathbb{C}^*)^2$ defined by $(a/5, b/5) \mapsto (\zeta_5^a, \zeta_5^b)$ induces an exact sequence

$$0 \longrightarrow N' \longrightarrow N \longrightarrow G \longrightarrow 0.$$

- (b) Let $\sigma = \text{Cone}(e_1, e_2) \subseteq N'_{\mathbb{R}} = N_{\mathbb{R}} = \mathbb{R}^2$. The inclusion $N' \rightarrow N$ induces a toric morphism $U_{\sigma, N'} \rightarrow U_{\sigma, N}$. Prove that this is the quotient map $\mathbb{C}^2 \rightarrow \mathbb{C}^2/G$ for the above action of G on \mathbb{C}^2 .
- (c) Find the Hilbert basis (i.e., the set of irreducible elements) of the semigroup $\sigma \cap N$. Hint: The Hilbert basis has four elements.
- (d) Use the Hilbert basis from part (c) to subdivide σ . This gives a fan Σ with $|\Sigma| = \sigma$. Prove that Σ is smooth relative to N and that the resulting toric morphism

$$X_{\Sigma, N} \rightarrow U_{\sigma, N} = \mathbb{C}^2/G$$

is a resolution of singularities. See Chapter 10 for more details.

- (e) The group G gives the finite set $G \subseteq (\mathbb{C}^*)^2 \subseteq \mathbb{C}^2$ with ideal $\mathbf{I}(G) = \langle x^5 - 1, y - x^3 \rangle$. Read about the *Gröbner fan* in [36, Ch. 8, §4] and compute the Gröbner fan of $\mathbf{I}(G)$. The answer will be identical to the fan described in part (d). This is no accident, as shown in the paper [94] (see also §10.3). There is a lot of interesting mathematics going on here, including the McKay correspondence and the G -Hilbert scheme. See also [124] for the higher dimensional case.

3.3.10. Consider the fan Σ in \mathbb{R}^3 shown in Figure 12 on the next page. This fan has five 1-dimensional cones with four “upward” ray generators $(\pm 1, 0, 1)$, $(0, \pm 1, 1)$ and one “downward” generator $(0, 0, -1)$. There are also nine 1-dimensional cones. Figure 12 shows five of the 2-dimensional cones; the remaining four are generated by the combining the downward generator with the four upward generators.

- (a) Show that projection onto the y -axis induces a toric morphism $X_{\Sigma} \rightarrow \mathbb{P}^1$.
- (b) Show that $X_{\Sigma} \rightarrow \mathbb{P}^1$ is a locally trivial fiber bundle over \mathbb{P}^1 with fiber $\mathbb{P}(1, 1, 2)$. Hint: Theorem 3.3.19 and $(1, 0, 1) + (-1, 0, 1) + 2(0, 0, -1) = 0$. See Example 3.1.17.

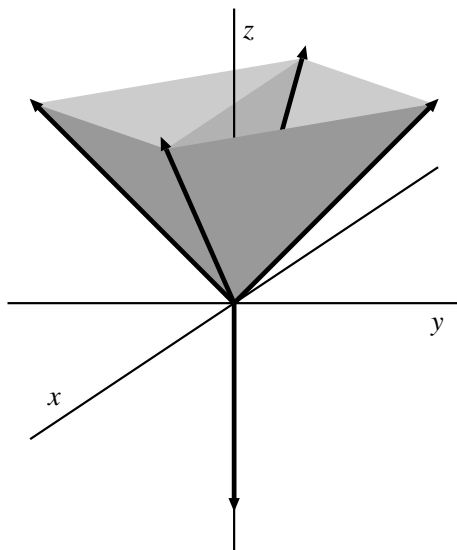

Figure 12. A fan Σ in \mathbb{R}^3

- (c) Explain how you can see the splitting (in the sense of Definition 3.3.18) in Figure 12. Also explain why the figure makes it clear that the fiber is $\mathbb{P}(1, 1, 2)$.

3.3.11. Consider the fan Σ in \mathbb{R}^2 with ray generators

$$u_0 = e_1 + e_2, u_1 = e_1, u_2 = e_2, u_3 = -e_1$$

and 1-dimensional cones $\text{Cone}(u_0, u_1)$, $\text{Cone}(u_0, u_2)$, $\text{Cone}(u_2, u_3)$.

- (a) Draw a picture of Σ and prove that X_Σ is the blowup of $\mathbb{P}^1 \times \mathbb{C}$ at one point.
 (b) Show that the map $ae_1 + be_2 \mapsto b$ induces a toric morphism $\phi : X_\Sigma \rightarrow \mathbb{C}$ such that $\phi^{-1}(\alpha) \simeq \mathbb{P}^1$ for $\alpha \in \mathbb{C}^*$ and $\phi^{-1}(0)$ is a union of two copies of \mathbb{P}^1 meeting at a point. Hint: Once you understand $\phi^{-1}(0)$, show that the fan for $X_\Sigma \setminus \phi^{-1}(0)$ gives $\mathbb{P}^1 \times \mathbb{C}^*$.
 (c) To get a better picture of X_Σ , consider the map $\Phi : (\mathbb{C}^*)^2 \rightarrow \mathbb{P}^3 \times \mathbb{C}$ defined by

$$\Phi(s, t) = ((s^3, s^2, st, t^2), t).$$

Let $X = \overline{\Phi((\mathbb{C}^*)^2)} \subseteq \mathbb{P}^3 \times \mathbb{C}$ be the closure of the image. Prove that $X \simeq X_\Sigma$ and that the restriction of the projection $\mathbb{P}^3 \times \mathbb{C} \rightarrow \mathbb{C}$ to X gives the toric morphism ϕ of part (b).

- (d) Let x, y, z, w be coordinates on \mathbb{P}^3 . Prove that $X \subseteq \mathbb{P}^3 \times \mathbb{C}$ is defined by the equations

$$yw - z^2 = 0, xz - ty^2 = 0, xw - tyz = 0.$$

Also use these equations to describe the fibers $\phi^{-1}(\alpha)$ for $\alpha \in \mathbb{C}$, and explain how this relates to part (b). Hint: The twisted cubic is relevant.

This is a *semi-stable degeneration of toric varieties*. See [90] for more details.

§3.4. Complete and Proper

The Compactness Criterion. We begin by proving part (c) of Theorem 3.1.19.

Theorem 3.4.1. *The following are equivalent for a toric variety X_Σ .*

- (a) X_Σ is compact in the classical topology.
- (b) The limit $\lim_{t \rightarrow 0} \lambda^u(t)$ exists in X_Σ for all $u \in N$.
- (c) Σ is complete, i.e., $|\Sigma| = \bigcup_{\sigma \in \Sigma} \sigma = N_{\mathbb{R}}$.

Proof. First observe that since X_Σ is separated (Theorem 3.1.5), it is Hausdorff in the classical topology (Theorem 3.0.17). In fact, since the classical topology on each affine open set U_σ is a metric topology, X_Σ is compact if and only if every sequence of points in X_Σ has a convergent subsequence.

For (a) \Rightarrow (b), assume that X_Σ is compact and fix $u \in N$. Given a sequence $t_k \in \mathbb{C}^*$ converging to 0, we get the sequence $\lambda^u(t_k) \in X_\Sigma$. By compactness, this sequence has a convergent subsequence. Passing to this subsequence, we can assume that $\lim_{k \rightarrow \infty} \lambda^u(t_k) = \gamma \in X_\Sigma$. Because X_Σ is the union of the affine open subsets U_σ for $\sigma \in \Sigma$, we may assume $\gamma \in U_\sigma$. Now take $m \in \sigma^\vee \cap M$. The character χ^m is a regular function on U_σ and hence is continuous in the classical topology. Thus

$$\chi^m(\gamma) = \lim_{k \rightarrow \infty} \chi^m(\lambda^u(t_k)) = \lim_{k \rightarrow \infty} t_k^{\langle m, u \rangle}.$$

Since $t_k \rightarrow 0$, the exponent must be nonnegative, i.e., $\langle m, u \rangle \geq 0$ for all $m \in \sigma^\vee \cap M$. This implies $\langle m, u \rangle \geq 0$ for all $m \in \sigma^\vee$, so that $u \in (\sigma^\vee)^\vee = \sigma$. Then Proposition 3.2.2 implies that $\lim_{t \rightarrow 0} \lambda^u(t)$ exists in U_σ and hence in X_Σ .

To prove (b) \Rightarrow (c), take $u \in N$ and consider the limit $\lim_{t \rightarrow 0} \lambda^u(t)$. This lies in some affine open U_σ , which implies $u \in \sigma \cap N$ by Proposition 3.2.2. Thus every lattice point of $N_{\mathbb{R}}$ is contained in a cone of Σ . It follows that Σ is complete.

We will prove (c) \Rightarrow (a) by induction on $n = \dim N_{\mathbb{R}}$. In the case $n = 1$, the only complete fan Σ is the fan in \mathbb{R} pictured in Example 3.1.11. The corresponding toric variety is $X_\Sigma = \mathbb{P}^1$. This is homeomorphic to S^2 , the 2-dimensional sphere, and hence is compact.

Now assume the statement is true for all complete fans of dimension strictly less than n , and consider a complete fan Σ in $N_{\mathbb{R}} \simeq \mathbb{R}^n$. Let $\gamma_k \in X_\Sigma$ be a sequence. We will show that γ_k has a convergent subsequence.

Since X_Σ is the union of finitely many orbits $O(\tau)$, we may assume the sequence γ_k lies entirely within an orbit $O(\tau)$. If $\tau \neq \{0\}$, then the closure of $O(\tau)$ in X_Σ is the toric variety $V(\tau) = X_{\text{Star}(\tau)}$ of dimension $\leq n - 1$ by Proposition 3.2.7. Since Σ is complete, it is easy to check that the fan $\text{Star}(\tau)$ is complete in $N(\tau)_{\mathbb{R}}$ (Exercise 3.4.1). Then the induction hypothesis implies that there is a convergent subsequence in $V(\tau)$. Hence, without loss of generality again, we may assume that our sequence lies entirely in the torus $T_N \subseteq X_\Sigma$.

Recall from the discussion following Lemma 3.2.5 that

$$T_N \simeq \text{Hom}_{\mathbb{Z}}(M, \mathbb{C}^*).$$

Moreover, when we regard $\gamma \in T_N$ as a group homomorphism $\gamma : M \rightarrow \mathbb{C}^*$, then for any $\sigma \in \Sigma$, restriction yields a semigroup homomorphism $\sigma^\vee \cap M \rightarrow \mathbb{C}$ and hence a point γ in U_σ .

A key ingredient of the proof will be the logarithm map $L : T_N \rightarrow N_{\mathbb{R}}$ defined as follows. Given a point $\gamma : M \rightarrow \mathbb{C}^*$ of T_N , consider the map $M \rightarrow \mathbb{R}$ defined by the formula

$$m \mapsto \log |\gamma(m)|.$$

This is a homomorphism and hence gives an element $L(\gamma) \in \text{Hom}_{\mathbb{Z}}(M, \mathbb{R}) \simeq N_{\mathbb{R}}$. For more properties of this mapping, see Exercise 3.4.2 below.

For us, the most important property of L is the following. Suppose that a point $\gamma \in T_N$ satisfies $L(\gamma) \in -\sigma$ for some $\sigma \in \Sigma$. If $m \in \sigma^\vee \cap M$, then the definition of L implies that

$$(3.4.1) \quad \log |\gamma(m)| = \langle m, L(\gamma) \rangle,$$

which is ≤ 0 since $m \in \sigma^\vee$ and $L(\gamma) \in -\sigma$. Hence $|\gamma(m)| \leq 1$. Thus we have proved that

$$(3.4.2) \quad L(\gamma) \in -\sigma \implies |\gamma(m)| \leq 1 \text{ for all } m \in \sigma^\vee \cap M.$$

Now apply L to our sequence, which gives a sequence $L(\gamma_k) \in N_{\mathbb{R}}$. Since Σ is complete, the same is true for the fan consisting of the cones $-\sigma$ for $\sigma \in \Sigma$. Hence, by passing to a subsequence, we may assume that there is $\sigma \in \Sigma$ such that

$$L(\gamma_k) \in -\sigma$$

for all k . By (3.4.2), we conclude that $|\gamma_k(m)| \leq 1$ for all $m \in \sigma^\vee \cap M$. It follows that the γ_k are a sequence of mappings to the closed unit disk in \mathbb{C} . Since the closed unit disk is compact, there is a subsequence γ_{k_ℓ} which converges to a point $\gamma \in U_\sigma$. You will check the details of this final assertion in Exercise 3.4.3. \square

Proper Mappings. The property of compactness also has a relative version that is used often in the theory of complex manifolds.

Definition 3.4.2. A continuous mapping $f : X \rightarrow Y$ is **proper** if the inverse image $f^{-1}(T)$ is compact in X for every compact subset $T \subseteq Y$.

It is immediate that X is compact if and only if the constant mapping from X to the space $Y = \{\text{pt}\}$ consisting of a single point is proper. This relative version of compactness may also be reformulated, for reasonably nice topological spaces, in the following way.

Proposition 3.4.3. Let $f : X \rightarrow Y$ be a continuous mapping of locally compact first countable Hausdorff spaces. Then the following are equivalent:

- (a) f is proper.
 (b) f is a closed mapping, i.e., $f(U) \subseteq Y$ is closed for all closed subsets $U \subseteq X$, and all fibers $f^{-1}(y)$, $y \in Y$, are compact.
 (c) Every sequence $x_k \in X$ such that $f(x_k) \in Y$ converges in Y has a subsequence x_{k_ℓ} that converges in X .

Proof. A proof of (a) \Leftrightarrow (b) can be found in [69, Ch. 9, §4]. See Exercise 3.4.4 for (a) \Leftrightarrow (c). \square

Before we can give a definition of properness that works for morphisms, we need another criterion for properness. Recall from §3.0 that morphisms $f : X \rightarrow S$ and $g : Y \rightarrow S$ give the fiber product $X \times_S Y$. Fiber products can also be defined for continuous maps between topological spaces. In Exercise 3.4.4, you will prove that properness can be formulated using fiber products as follows.

Proposition 3.4.4. Let $f : X \rightarrow Y$ be a continuous map between locally compact Hausdorff spaces. Then f is proper if and only if f is **universally closed**, meaning that for all spaces Z and all continuous mappings $g : Z \rightarrow Y$, the projection π_Z defined by the commutative diagram

$$\begin{array}{ccc} X \times_Y Z & \xrightarrow{\pi_X} & X \\ \pi_Z \downarrow & & \downarrow f \\ Z & \xrightarrow{g} & Y \end{array}$$

is a closed mapping.

In algebraic geometry, it is customary to use the following definition of properness for morphisms of algebraic varieties.

Definition 3.4.5. A morphism of varieties $\phi : X \rightarrow Y$ is **proper** if it is **universally closed**, in the sense that for all varieties Z and morphisms $\psi : Z \rightarrow Y$, the projection π_Z defined by the commutative diagram

$$\begin{array}{ccc} X \times_Y Z & \xrightarrow{\pi_X} & X \\ \pi_Z \downarrow & & \downarrow \phi \\ Z & \xrightarrow{\psi} & Y \end{array}$$

is a closed mapping in the Zariski topology. A variety X is said to be **complete** if the constant morphism $\phi : X \rightarrow \{\text{pt}\}$ is proper.

Example 3.4.6. The Projective Extension Theorem [35, Thm. 6 of Ch. 8, §5] shows that for $X = \mathbb{P}^n$, the mapping

$$\pi_{\mathbb{C}^m} : \mathbb{P}^n \times \mathbb{C}^m \rightarrow \mathbb{C}^m$$

is closed in the Zariski topology for all m . It follows that if $V \subseteq \mathbb{C}^m$ is any affine variety, the projection

$$\pi_V : \mathbb{P}^n \times V \rightarrow V$$

is a closed mapping in the Zariski topology. By the gluing construction, it follows that the constant morphism $\mathbb{P}^n \rightarrow \{\text{pt}\}$ is proper, so \mathbb{P}^n is a complete variety. In fact, one can think of \mathbb{P}^n as the prototypical complete variety. Moreover, any projective variety is complete (Exercise 3.4.5). However, there are complete varieties that are not projective—we will give a toric example in Chapter 6.

On the other hand, consider the morphism $\mathbb{C} \rightarrow \{\text{pt}\}$. We claim that this is not proper, so \mathbb{C} is not complete. To see this, consider $\mathbb{C} \times_{\{\text{pt}\}} \mathbb{C} = \mathbb{C}^2$ and the diagram

$$\begin{array}{ccc} \mathbb{C}^2 & \xrightarrow{\pi_2} & \mathbb{C} \\ \pi_1 \downarrow & & \downarrow \\ \mathbb{C} & \longrightarrow & \{\text{pt}\}. \end{array}$$

The closed subset $\mathbf{V}(xy - 1) \subseteq \mathbb{C}^2$ does not map to a Zariski-closed subset of \mathbb{C} under π_1 . Hence π_1 is not a closed mapping, so that \mathbb{C} is not complete. \diamond

Completeness is the algebraic version of compactness, and it can be shown that a variety is complete if and only if it is compact in the classical topology. This is proved in Serre's famous paper *Géométrie algébrique et géométrie analytique*, called GAGA for short. See [155, Prop. 6, p. 12].

The Properness Criterion. Theorem 3.4.1 can be understood as a special case of the following statement for toric morphisms.

Theorem 3.4.7. *Let $\phi : X_\Sigma \rightarrow X_{\Sigma'}$ be the toric morphism corresponding to a homomorphism $\bar{\phi} : N \rightarrow N'$ that is compatible with fans Σ in $N_{\mathbb{R}}$ and Σ' in $N'_{\mathbb{R}}$. Then the following are equivalent:*

- (a) $\phi : X_\Sigma \rightarrow X_{\Sigma'}$ is proper in the classical topology (Definition 3.4.2).
- (b) $\phi : X_\Sigma \rightarrow X_{\Sigma'}$ is a proper morphism (Definition 3.4.5).
- (c) If $u \in N$ and $\lim_{t \rightarrow 0} \lambda^{\bar{\phi}(u)}(t)$ exists in $X_{\Sigma'}$, then $\lim_{t \rightarrow 0} \lambda^u(t)$ exists in X_Σ .
- (d) $\bar{\phi}_{\mathbb{R}}^{-1}(|\Sigma'|) = |\Sigma|$.

Proof. The proof of (a) \Rightarrow (b) uses two fundamental results in algebraic geometry.

First, given any morphism of varieties $f : X \rightarrow Y$ and a Zariski closed subset $W \subseteq X$, a theorem of Chevalley tells us that the image $f(W) \subseteq Y$ is *constructible*, meaning that it can be written as a finite union $f(W) = \bigcup_i (V_i \setminus W_i)$, where V_i and W_i are Zariski closed in Y . A proof appears in [77, Ex. II.3.19].

Second, given any constructible subset C of a variety Y , its closure in Y in the classical topology equals its closure in the Zariski topology. When C is open in the

Zariski topology, a proof is given in [125, Thm. (2.33)], and when C is the image of a morphism, a proof can be found in GAGA [155, Prop. 7, p. 12].

Now suppose that $\phi : X_\Sigma \rightarrow X_{\Sigma'}$ is proper in the classical topology and let $\psi : Z \rightarrow X_{\Sigma'}$ be a morphism. This gives the commutative diagram

$$\begin{array}{ccc} X_\Sigma \times_{X_{\Sigma'}} Z & \longrightarrow & X_\Sigma \\ \pi_Z \downarrow & & \downarrow \phi \\ Z & \xrightarrow{\psi} & X_{\Sigma'} \end{array}$$

Let $Y \subseteq X_\Sigma \times_{X_{\Sigma'}} Z$ be Zariski closed. We need to prove that $\pi_Z(Y)$ is Zariski closed in Z . First observe that Y is also closed in the classical topology, so that $\pi_Z(Y)$ is closed in Z in the classical topology by Proposition 3.4.4. However, $\pi_Z(Y)$ is constructible by Chevalley's Theorem, and then, being classically closed, it is also Zariski closed by GAGA. Hence π_Z is a closed map in the Zariski topology for any morphism $\psi : Z \rightarrow X_{\Sigma'}$. It follows that ϕ is a proper morphism.

To prove (b) \Rightarrow (c), let $u \in N$ and assume that $\gamma' = \lim_{t \rightarrow 0} \lambda^{\overline{\phi}(u)}(t)$ exists in $X_{\Sigma'}$. We first prove $\lim_{t \rightarrow 0} \lambda^u(t)$ exists in X_Σ under the extra assumption that $\overline{\phi}(u) \neq 0$. This means that $\lambda^{\overline{\phi}(u)}$ is a nontrivial one-parameter subgroup in $X_{\Sigma'}$.

Let $\overline{\lambda^u(\mathbb{C}^*)} \subseteq X_\Sigma$ be the closure of $\lambda^u(\mathbb{C}^*) \subseteq X_\Sigma$ in the classical topology. Our earlier remarks imply that this equals the Zariski closure. Since ϕ is proper, it is closed in the Zariski topology, so that $\phi(\overline{\lambda^u(\mathbb{C}^*)})$ is closed in $X_{\Sigma'}$ in both topologies. It follows that

$$\overline{\lambda^{\overline{\phi}(u)}(\mathbb{C}^*)} \subseteq \phi(\overline{\lambda^u(\mathbb{C}^*)}).$$

Hence there is $\gamma \in \overline{\lambda^u(\mathbb{C}^*)}$ mapping to γ' . Thus there is a sequence of points $t_k \in \mathbb{C}^*$ such that $\lambda^u(t_k) \rightarrow \gamma$. Then

$$\gamma' = \phi(\gamma) = \lim_{k \rightarrow \infty} \phi(\lambda^u(t_k)) = \lim_{k \rightarrow \infty} \lambda^{\overline{\phi}(u)}(t_k).$$

This, together with $\gamma' = \lim_{t \rightarrow 0} \lambda^{\overline{\phi}(u)}(t)$ and $\overline{\phi}(u) \neq 0$, imply that $t_k \rightarrow 0$. From here, the arguments used to prove (a) \Rightarrow (b) \Rightarrow (c) of Theorem 3.4.1 easily imply that $\lim_{t \rightarrow 0} \lambda^u(t)$ exists in X_Σ .

For the general case when we no longer assume $\overline{\phi}(u) \neq 0$, consider the map $(\phi, 1_{\mathbb{C}}) : X_\Sigma \times \mathbb{C} \rightarrow X_{\Sigma'} \times \mathbb{C}$. This is proper since ϕ is proper (Exercise 3.4.6). Furthermore, $X_\Sigma \times \mathbb{C}$ and $X_{\Sigma'} \times \mathbb{C}$ are toric varieties by Proposition 3.1.14, and the corresponding map on lattices is $(\overline{\phi}, 1_{\mathbb{Z}}) : N \times \mathbb{Z} \rightarrow N' \times \mathbb{Z}$. Then applying the above argument to $(u, 1) \in N \times \mathbb{Z}$ shows that $\lim_{t \rightarrow 0} \lambda^u(t)$ exists in X_Σ . We leave the details to the reader (Exercise 3.4.6).

For (c) \Rightarrow (d), first observe that the inclusion

$$|\Sigma| \subseteq \overline{\phi}_{\mathbb{R}}^{-1}(|\Sigma'|)$$

is automatic since $\bar{\phi}$ is compatible with Σ and Σ' . For the opposite inclusion, take $u \in \bar{\phi}_{\mathbb{R}}^{-1}(|\Sigma'|) \cap N$. Then $\bar{\phi}(u) \in |\Sigma'|$, which by Proposition 3.2.2 implies that $\lim_{t \rightarrow 0} \lambda^{\bar{\phi}(u)}(t)$ exists in $X_{\Sigma'}$. By assumption, $\lim_{t \rightarrow 0} \lambda^u(t)$ exists in X_{Σ} . Using Proposition 3.2.2, we conclude that $u \in \sigma \cap N$ for some $\sigma \in \Sigma$. Because all the cones are rational, this immediately implies $\bar{\phi}_{\mathbb{R}}^{-1}(|\Sigma'|) \subseteq |\Sigma|$.

Finally, we prove (d) \Rightarrow (a). We begin with two special cases.

Special Case 1. Suppose that a toric morphism $\phi : X_{\Sigma} \rightarrow T_{N'}$ satisfies (d) and has the additional property that $\bar{\phi} : N \rightarrow N'$ is onto. The fan of $T_{N'}$ consists of the trivial cone $\{0\}$, so that (d) implies

$$(3.4.3) \quad |\Sigma| = \bar{\phi}_{\mathbb{R}}^{-1}(0) = \ker(\bar{\phi}_{\mathbb{R}}).$$

When we think of Σ as a fan Σ'' in $\ker(\bar{\phi}_{\mathbb{R}}) \subseteq N_{\mathbb{R}}$, (3.3.5) implies that

$$X_{\Sigma} \simeq X_{\Sigma''} \times T_{N'}.$$

Then ϕ corresponds to the projection $X_{\Sigma''} \times T_{N'} \rightarrow T_{N'}$. The fan Σ'' is complete in $\ker(\bar{\phi}_{\mathbb{R}})$ by (3.4.3), so that $X_{\Sigma''}$ is compact by Theorem 3.4.1. Thus $X_{\Sigma''} \rightarrow \{\text{pt}\}$ is proper, which easily implies that $X_{\Sigma''} \times T_{N'} \rightarrow T_{N'}$ is proper. We conclude that ϕ is proper in the classical topology.

Special Case 2. Suppose that a homomorphism of tori $\phi : T_N \rightarrow T_{N'}$ has the additional property that $\bar{\phi} : N \rightarrow N'$ is injective. Then (d) is obviously satisfied. An elementary proof that ϕ is proper is given in Exercise 3.4.7.

Now consider a general toric morphism $\phi : X_{\Sigma} \rightarrow X_{\Sigma'}$ satisfying (d). We will prove that ϕ is proper in the classical topology using part (c) of Proposition 3.4.3. Thus assume that $\gamma_k \in X_{\Sigma}$ is a sequence such that $\phi(\gamma_k)$ converges in $X_{\Sigma'}$. We need to prove that a subsequence of γ_k converges in X_{Σ} .

Since X_{Σ} has only finitely many T_N -orbits, we may assume that the sequence lies in an orbit $O(\sigma)$. As in Lemma 3.3.21, let σ' be the minimal cone of Σ' containing $\bar{\phi}_{\mathbb{R}}(\sigma)$. The restriction

$$\phi|_{V(\sigma)} : V(\sigma) \rightarrow V(\sigma')$$

is a toric morphism by Lemma 3.3.21, and the fans of $V(\sigma)$ and $V(\sigma')$ are given by $\text{Star}(\sigma)$ in $N(\sigma)_{\mathbb{R}}$ and $\text{Star}(\sigma')$ in $N'(\sigma')_{\mathbb{R}}$ respectively. Furthermore, one can check that since Σ and Σ' satisfy (d), the same is true for the fans $\text{Star}(\sigma)$ and $\text{Star}(\sigma')$ (Exercise 3.4.8). Hence we may assume that $\gamma_k \in T_N$ and $\phi(\gamma_k) \in T_{N'}$ for all k .

The limit $\gamma' = \lim_{k \rightarrow \infty} \phi(\gamma_k)$ lies in an orbit $O(\tau')$ for some $\tau' \in \Sigma'$. Thus the sequence $\phi(\gamma_k)$ and its limit γ' all lie in $U_{\tau'}$. Note that $\{\sigma \in \Sigma \mid \bar{\phi}(\sigma) \subset \tau'\}$ is the fan giving $\bar{\phi}^{-1}(U_{\tau'})$. Since (d) implies that

$$\bar{\phi}_{\mathbb{R}}^{-1}(\tau') = \bigcup_{\bar{\phi}_{\mathbb{R}}(\sigma) \subseteq \tau'} \sigma,$$

we can assume that $X_{\Sigma'} = U_{\tau'}$, i.e., $\phi : X_{\Sigma} \rightarrow U_{\tau'}$ and $\bar{\phi}^{-1}(\tau') = |\Sigma|$.

If $\tau' = \{0\}$, then $O(\tau') = U_{\tau'} = T'_N$. If we write $\bar{\phi}$ as the composition

$$N \twoheadrightarrow \bar{\phi}(N) \hookrightarrow N',$$

then $\phi : X_\Sigma \rightarrow T_{N'}$ factors $X_\Sigma \rightarrow T_{\bar{\phi}(N)} \rightarrow T_{N'}$. Special Cases 1 and 2 imply that these maps are proper, and since the composition of proper maps is proper, we conclude that ϕ is proper.

It remains to consider the case when $\tau' \neq \{0\}$. When we think of $\gamma' \in U_{\tau'}$ as a semigroup homomorphism $\gamma' : (\tau')^\vee \cap M \rightarrow \mathbb{C}$, Lemma 3.2.5 tells us that

$$\gamma'(m') = 0 \text{ for all } m' \in (\tau')^\vee \cap M' \setminus (\tau')^\perp \cap M'.$$

Since the $\phi(\gamma_k) : M \rightarrow \mathbb{C}^*$ converge to γ' in $U_{\tau'}$, we see that

$$\lim_{k \rightarrow \infty} \phi(\gamma_k)(m') = 0 \text{ for all } m' \in (\tau')^\vee \cap M' \setminus (\tau')^\perp \cap M'.$$

Since $(\tau')^\vee \cap M'$ is finitely generated, it follows that we may pass to a subsequence and assume that

$$(3.4.4) \quad |\phi(\gamma_k)(m')| \leq 1 \text{ for all } k \text{ and all } m' \in (\tau')^\vee \cap M' \setminus (\tau')^\perp \cap M'.$$

The logarithm map from the proof of Theorem 3.4.1 gives maps $L_N : T_N \rightarrow N_{\mathbb{R}}$ and $L_{N'} : T_{N'} \rightarrow N'_{\mathbb{R}}$ linked by a commutative diagram:

$$\begin{array}{ccc} T_N & \xrightarrow{L_N} & N_{\mathbb{R}} \\ \phi|_{T_N} \downarrow & & \downarrow \bar{\phi}_{\mathbb{R}} \\ T_{N'} & \xrightarrow{L_{N'}} & N'_{\mathbb{R}} \end{array}$$

Let $\bar{\phi}^* : M' \rightarrow M$ be dual to $\bar{\phi} : N \rightarrow N'$. Then $m' \in (\tau')^\vee \cap M' \setminus (\tau')^\perp \cap M'$ implies that for all k , we have

$$(3.4.5) \quad \begin{aligned} \langle \bar{\phi}^*(m'), L_N(\gamma_k) \rangle &= \langle m', \bar{\phi}_{\mathbb{R}}(L_N(\gamma_k)) \rangle \\ &= \langle m', L_{N'}(\phi(\gamma_k)) \rangle = \log |\phi(\gamma_k)(m')| \leq 0, \end{aligned}$$

where the first equality is standard, the second follows from the above commutative diagram, the third follows from (3.4.1), and the final inequality uses (3.4.4).

Now consider the following equivalences:

$$\begin{aligned} u \in \bar{\phi}_{\mathbb{R}}^{-1}(\tau') &\iff \bar{\phi}_{\mathbb{R}}(u) \in \tau' \\ &\iff \langle m', \bar{\phi}_{\mathbb{R}}(u) \rangle \geq 0 \text{ for all } m' \in (\tau')^\vee \cap M' \\ &\iff \langle \bar{\phi}^*(m'), u \rangle \geq 0 \text{ for all } m' \in (\tau')^\vee \cap M', \end{aligned}$$

where the first and third equivalences are obvious and the second uses $\tau' = (\tau')^{\vee\vee}$ and the rationality of τ' . But we also know that $\tau' \neq \{0\}$, which means that $(\tau')^\vee$ is a cone whose maximal subspace $(\tau')^\perp$ is a proper subset. This implies that

$$u \in \bar{\phi}_{\mathbb{R}}^{-1}(\tau') \iff \langle \bar{\phi}^*(m'), u \rangle \geq 0 \text{ for all } m' \in (\tau')^\vee \cap M' \setminus (\tau')^\perp \cap M'$$

(Exercise 3.4.9). Using (3.4.5), we conclude that $-L_N(\gamma_k) \in \overline{\phi}_{\mathbb{R}}^{-1}(\tau')$ for all k . But, as noted above, (d) means $\overline{\phi}^{-1}(\tau') = |\Sigma|$. It follows that

$$-L_N(\gamma_k) \in |\Sigma|$$

for all k . Passing to a subsequence, we may assume that there is $\sigma \in \Sigma$ such that

$$L_N(\gamma_k) \in -\sigma$$

for all k . From here, the proof of (c) \Rightarrow (a) in Theorem 3.4.1 implies that there is a subsequence γ_{k_ℓ} which converges to a point $\gamma \in U_\sigma \subseteq X_\Sigma$. This proves that ϕ is proper in the classical topology. The proof of the theorem is now complete. \square

An immediate corollary of Theorem 3.4.7 is the following more complete version of Theorem 3.4.1.

Corollary 3.4.8. *The following are equivalent for a toric variety X_Σ .*

- (a) X_Σ is compact in the classical topology.
- (b) X_Σ is complete.
- (c) The limit $\lim_{t \rightarrow 0} \lambda^u(t)$ exists in X_Σ for all $u \in N$.
- (d) Σ is complete, i.e., $|\Sigma| = \bigcup_{\sigma \in \Sigma} \sigma = N_{\mathbb{R}}$. \square

We noted earlier that a variety is complete if and only if it is compact. In a similar way, a morphism $f : X \rightarrow Y$ of varieties is a proper morphism if and only if it is proper in the classical topology. This is proved in [72, Prop. 3.2 of Exp. XII]. Thus the equivalences (a) \Leftrightarrow (b) of Theorem 3.4.7 and Corollary 3.4.8 are special cases of this general phenomenon.

Theorem 3.4.7 and Corollary 3.4.8 show that properness and completeness can be tested using one-parameter subgroups. In the case of completeness, we can formulate this as follows. Given $u \in N$, the one-parameter subgroup gives a map $\lambda^u : \mathbb{C} \setminus \{0\} \rightarrow T_N \subseteq X_\Sigma$, and saying that $\lim_{t \rightarrow 0} \lambda^u(t)$ exists in X_Σ means that λ^u extends to a morphism $\lambda_0^u : \mathbb{C} \rightarrow X_\Sigma$. In other words, whenever we have a commutative diagram

$$\begin{array}{ccc}
 \mathbb{C} \setminus \{0\} & \xrightarrow{\lambda^u} & X_\Sigma \\
 \downarrow i & \nearrow \lambda_0^u & \downarrow \phi \\
 \mathbb{C} & \xrightarrow{\lambda_0^{\overline{\phi}(u)}} & \{\text{pt}\},
 \end{array}$$

the dashed arrow λ_0^u exists. The existence of λ_0^u tells us that X_Σ is not missing any points, which is where the term “complete” comes from. In a similar way, the properness criterion given in part (c) of Theorem 3.4.7 can be formulated as saying

that whenever $u \in N$ gives a commutative diagram,

$$\begin{array}{ccc}
 \mathbb{C} \setminus \{0\} & \xrightarrow{\lambda^u} & X_\Sigma \\
 \downarrow i & \nearrow \lambda_0^u & \downarrow \phi \\
 \mathbb{C} & \xrightarrow{\lambda_0^{\bar{\phi}(u)}} & X_{\Sigma'}
 \end{array}$$

the dashed arrow λ_0^u exists so that the diagram remains commutative.

For general varieties, there are similar criteria for completeness and properness that replace $\lambda^u : \mathbb{C} \setminus \{0\} \rightarrow X_\Sigma$ and $\lambda_0^u : \mathbb{C} \rightarrow X_\Sigma$ with maps coming from *discrete valuation rings*, to be discussed in Chapter 4. An example of a discrete valuation ring is the ring of formal power series $R = \mathbb{C}[[t]]$, whose field of fractions is the field of formal Laurent series $K = \mathbb{C}((t))$. By replacing \mathbb{C} with $\text{Spec}(R)$ and $\mathbb{C} \setminus \{0\}$ with $\text{Spec}(K)$ in the above diagrams, where R is now an arbitrary discrete valuation ring, one gets the *valuative criterion for properness* ([77, Ex. II.4.11 and Thm. II.4.7]). This requires the full power of scheme theory since $\text{Spec}(R)$ and $\text{Spec}(K)$ are not varieties as defined in this book. Using the valuative criterion of properness, one can give a direct, purely algebraic proof of (d) \Rightarrow (b) in Theorem 3.4.7 and Corollary 3.4.8 (see [58, Sec. 2.4] or [134, Sec. 1.5]).

Example 3.4.9. An important class of proper morphisms are the toric morphisms $\phi : X_{\Sigma'} \rightarrow X_\Sigma$ induced by a refinement Σ' of Σ . Condition (d) of Theorem 3.4.7 is obviously fulfilled since $\bar{\phi} : N \rightarrow N$ is the identity and every cone of Σ is a union of cones of Σ' . In particular, the blowups

$$\phi : X_{\Sigma^*(\sigma)} \rightarrow X_\Sigma$$

studied in Proposition 3.3.15 are always proper. ◇

Exercises for §3.4.

3.4.1. Let Σ be a complete fan in $N_\mathbb{R}$ and let τ be a cone in Σ . Show that the fan $\text{Star}(\tau)$ defined in (3.2.8) is a complete fan in $N(\tau)_\mathbb{R}$.

3.4.2. In this exercise, you will develop some additional properties of the logarithm mapping $L : T_N \rightarrow N_\mathbb{R}$ defined in the proof of Theorem 3.4.1.

- (a) Let S^1 be the unit circle in the complex plane, a subgroup of the multiplicative group \mathbb{C}^* . Show that there is an isomorphism of groups

$$\begin{aligned}
 \Phi : \mathbb{C}^* &\longrightarrow S^1 \times \mathbb{R} \\
 z &\longmapsto (|z|, \log |z|),
 \end{aligned}$$

where the operation in the second factor on the right is addition.

- (b) Show that the compact real n -dimensional torus $(S^1)^n$ can be viewed as a subgroup of T_N and that $L : T_N \rightarrow N_\mathbb{R}$ induces an isomorphism $T_N / (S^1)^n \simeq N_\mathbb{R}$. Hint: Use Φ from part (a).

- (c) Let Σ be a fan in N . Show that the action of the compact real torus $(S^1)^n \subseteq T_N$ on T_N extends to an action on the toric variety X_Σ and that the quotient space

$$(X_\Sigma)/(S^1)^n \cong \bigcup_{\sigma} N(\sigma)_{\mathbb{R}},$$

where \cong denotes homeomorphism of topological spaces, and the union is over all cones in the fan. Hint: Use the Orbit-Cone Correspondence (Theorem 3.2.6).

- (d) Let Σ in \mathbb{R}^2 be the fan from Example 3.1.9, so that $X_\Sigma \simeq \mathbb{P}^2$. Show that under the action of $(S^1)^2 \subseteq (\mathbb{C}^*)^2$ as in part (c), $\mathbb{P}^2/(S^1)^2 \cong \Delta_2$, the 2-dimensional simplex.

We will say more about the topology of toric varieties in Chapter 12.

3.4.3. This exercise will complete the proof of Theorem 3.4.1. Let $\text{Hom}(\sigma^\vee \cap M, \mathbb{C})$ be the set of semigroup homomorphisms $\sigma^\vee \cap M \rightarrow \mathbb{C}$. Assume that $\gamma_k \in \text{Hom}(\sigma^\vee \cap M, \mathbb{C})$ is a sequence such that $|\gamma_k(m)| \leq 1$ for all $m \in \sigma^\vee \cap M$ and all k . We want to show that there is a subsequence γ_{k_ℓ} that converges to a point $\gamma \in \text{Hom}(\sigma^\vee \cap M, \mathbb{C})$.

- (a) The semigroup $S_\sigma = \sigma^\vee \cap M$ is generated by a finite set $\{m_1, \dots, m_s\}$. Use this fact and the compactness of $\{z \in \mathbb{C} \mid |z| \leq 1\}$ to show that there exists a subsequence γ_{k_ℓ} such that the sequences $\gamma_{k_\ell}(m_j)$ converge in \mathbb{C} for all j .
- (b) Deduce that the subsequence γ_{k_ℓ} converges to a $\gamma \in \text{Hom}(\sigma^\vee \cap M, \mathbb{C})$.

3.4.4. Here you will prove some characterizations of properness stated in the text.

- (a) Prove (a) \Leftrightarrow (c) from Proposition 3.4.3.
- (b) Prove Proposition 3.4.4. Hint: Show first that compactness of X is equivalent to the statement that the mapping $f : X \rightarrow \{\text{pt}\}$ is universally closed. Then use the easy fact that any composition of universally closed mappings is universally closed.

3.4.5. Show that any projective variety is complete according to Definition 3.4.5.

3.4.6. Complete the proof of (b) \Rightarrow (c) of Theorem 3.4.7 begun in the text.

3.4.7. Let $\phi : T_N \rightarrow T_{N'}$ be a map of tori corresponding to an injective homomorphism $\bar{\phi} : N \rightarrow N'$. Also let $\bar{\phi}^* : M' \rightarrow M$ be the dual map. Finally, let $\gamma_k \in T_N$ be a sequence such that $\phi(\gamma_k)$ converges to a point of $T_{N'}$.

- (a) Prove that $\text{im}(\bar{\phi}^*) \subseteq M$ has finite index. Hence we can pick an integer $d > 0$ such that $dM \subseteq \text{im}(\bar{\phi}^*)$.
- (b) Show that $\chi^m(\gamma_k)$ converges for all $m \in \text{im}(\bar{\phi}^*)$. Conclude that $\chi^m(\gamma_k^d)$ converges for all $m \in M$, where d is as in part (a).
- (c) Pick a basis of M so that $T_N \simeq (\mathbb{C}^*)^n$ and write $\gamma_k = (\gamma_{1,k}, \dots, \gamma_{n,k}) \in (\mathbb{C}^*)^n$. Show that $(\gamma_{1,k}^d, \dots, \gamma_{n,k}^d)$ converges to a point $(\tilde{\gamma}_1, \dots, \tilde{\gamma}_n) \in (\mathbb{C}^*)^n$.
- (d) Show that the d th roots $\tilde{\gamma}_i^{1/d}$ can be chosen so that a subsequence of the sequence $\gamma_k = (\gamma_{1,k}, \dots, \gamma_{n,k})$ converges to a point $\gamma = (\tilde{\gamma}_1^{1/d}, \dots, \tilde{\gamma}_n^{1/d}) \in T_N$.
- (e) Explain why this implies that $T_N \rightarrow T_{N'}$ is proper in the classical topology.

3.4.8. To finish the proof of (d) \Rightarrow (a) of Theorem 3.4.7, suppose we have a toric morphism $\phi : X_\Sigma \rightarrow X_{\Sigma'}$ and a cone $\sigma \in \Sigma$. Let $\sigma' \in \Sigma'$ be the smallest cone containing $\bar{\phi}_{\mathbb{R}}(\sigma)$.

- (a) Prove that $\bar{\phi}$ induces a homomorphism $\bar{\phi}_\sigma : N(\sigma) \rightarrow N(\sigma')$.
- (b) Assume further that $\bar{\phi}_{\mathbb{R}}^{-1}(|\Sigma'|) = |\Sigma|$. Prove that $(\bar{\phi}_\sigma)_{\mathbb{R}}^{-1}(|\text{Star}(\sigma')|) = |\text{Star}(\sigma)|$.

3.4.9. Let $\tau' \neq \{0\}$ be a strongly convex polyhedral cone in $N'_{\mathbb{R}}$. Prove that

$$u' \in \tau' \iff \langle m', u' \rangle \geq 0 \text{ for all } m' \in (\tau')^{\vee} \cap M \setminus (\tau')^{\perp} \cap M$$

and then apply this to $u' = \overline{\phi}_{\mathbb{R}}(u)$ to complete the argument in the text. Hint: To prove \Leftarrow , first show that the right hand side of the equivalence implies that $\langle m', u' \rangle \geq 0$ for all $m' \in (\tau')^{\vee} \cap M_{\mathbb{Q}} \setminus (\tau')^{\perp} \cap M_{\mathbb{Q}}$. Then show that $\tau' \neq \{0\}$ implies that any element of $(\tau')^{\vee} \cap M$ is a limit of elements in $(\tau')^{\vee} \cap M_{\mathbb{Q}} \setminus (\tau')^{\perp} \cap M_{\mathbb{Q}}$.

3.4.10. Give a second argument for the implication

$$X_{\Sigma} \text{ compact} \Rightarrow \Sigma \text{ complete}$$

from part (c) of Theorem 3.1.19 using induction on the dimension n of N . Hint: If Σ is not complete and $n > 1$, then there is a 1-dimensional cone τ in the boundary of the support of Σ . Consider the fan $\text{Star}(\tau)$ and the corresponding toric subvariety of X_{Σ} .

3.4.11. Let Σ', Σ be fans in $N_{\mathbb{R}}$ compatible with the identity map $N \rightarrow N$. Prove that the toric morphism $\phi : X_{\Sigma'} \rightarrow X_{\Sigma}$ is proper if and only if Σ' is a refinement of Σ .

Appendix: Nonnormal Toric Varieties

In this appendix, we discuss toric varieties that are not necessarily normal. We begin with an example to show that Sumihiro's Theorem (Theorem 3.1.7) on the existence of a torus-invariant affine open cover can fail in the nonnormal case.

Example 3.A.1. Consider the nodal cubic $C \subseteq \mathbb{P}^2$ defined by $y^2z = x^2(x+z)$. The only singularity of C is $p = (0, 0, 1)$. We claim that C is a toric variety with $C \setminus \{p\} \simeq \mathbb{C}^*$ as torus. Assuming this for the moment, consider a torus-invariant neighborhood of p . It contains p and the torus and hence is the whole curve! We conclude that p has no torus-invariant affine open neighborhood. Thus Sumihiro's Theorem fails for C .

To see that C is a toric variety, we begin with the standard parametrization obtained by intersecting lines $y = tx$ with the affine curve $y^2 = x^2(x+1)$. This easily leads to the parametrization

$$x = t^2 - 1, \quad y = t(t^2 - 1).$$

The values $t = \pm 1$ map to the singular point p . To get a parametrization that looks more like a torus, we replace t with $\frac{t+1}{t-1}$ to obtain

$$x = \frac{4t}{(t-1)^2}, \quad y = \frac{4t(t+1)}{(t-1)^3}.$$

Then $t = 0, \infty$ map to p and $t \in \mathbb{C}^*$ maps bijectively to $C \setminus \{p\}$.

Using this parametrization, we get $\mathbb{C}^* \subseteq C$, and the action of \mathbb{C}^* on itself given by multiplication extends to an action on C by making p a fixed point of the action. With some work, one can show that this action is algebraic and hence gives a toric variety. (For readers familiar with elliptic curves, the basic idea is that the description of the group law in terms of lines connecting points on the curve reduces to multiplication in $\mathbb{C}^* \subseteq C$ for our curve C .) \diamond

In contrast, the projective toric varieties constructed in Chapter 2 satisfy Sumihiro's Theorem by Proposition 2.1.8. Since these nonnormal toric varieties have a good local

structure, it is reasonable to expect that they share some of the nice properties of normal toric varieties. In particular, they satisfy a version of the Orbit-Cone Correspondence (Theorem 3.2.6).

We begin with the affine case. Given M and a finite subset $\mathcal{A} = \{m_1, \dots, m_s\} \subseteq M$, we get the affine toric variety $Y_{\mathcal{A}} \subseteq \mathbb{C}^s$ whose torus has character group $\mathbb{Z}\mathcal{A}$ (Proposition 1.1.8). Assume $M = \mathbb{Z}\mathcal{A}$ and let $\sigma \subseteq N_{\mathbb{R}}$ be dual to $\text{Cone}(\mathcal{A}) \subseteq M_{\mathbb{R}}$. By Proposition 1.3.8, the normalization of $Y_{\mathcal{A}}$ is the map

$$U_{\sigma} \longrightarrow Y_{\mathcal{A}}$$

induced by the inclusion of semigroup algebras

$$\mathbb{C}[\mathbb{N}\mathcal{A}] \subseteq \mathbb{C}[\sigma^{\vee} \cap M].$$

Recall that $\mathbb{C}[\sigma^{\vee} \cap M]$ is the integral closure of $\mathbb{C}[\mathbb{N}\mathcal{A}]$ in its field of fractions. We now apply standard results in commutative algebra and algebraic geometry:

- Since the integral closure $\mathbb{C}[\sigma^{\vee} \cap M]$ is a finitely generated \mathbb{C} -algebra, it is a finitely generated module over $\mathbb{C}[\mathbb{N}\mathcal{A}]$ (see [3, Cor. 5.8]).
- Thus the corresponding morphism $U_{\sigma} \rightarrow Y_{\mathcal{A}}$ is finite as defined in [77, p. 84].
- A finite morphism is proper with finite fibers (see [77, Ex. II.3.5 and II.4.1]).

Since $U_{\sigma} \rightarrow Y_{\mathcal{A}}$ is the identity on the torus, the image of the normalization is Zariski dense in $Y_{\mathcal{A}}$. But the image is also closed since the normalization map is proper. This proves that the normalization map is onto.

Here is an example of how the normalization map can fail to be one-to-one.

Example 3.A.2. The set $\mathcal{A} = \{e_1, e_1 + e_2, 2e_2\} \subseteq \mathbb{Z}^2$ gives the parametrization $\Phi_{\mathcal{A}}(s, t) = (s, st, t^2)$, and one can check that

$$Y_{\mathcal{A}} = \mathbf{V}(y^2 - x^2z) \subseteq \mathbb{C}^3.$$

Furthermore, $\mathbb{Z}\mathcal{A} = \mathbb{Z}^2$ and $\sigma = \text{Cone}(\mathcal{A})^{\vee} = \text{Cone}(e_1, e_2)$. It follows easily that the normalization is given by

$$\begin{aligned} \mathbb{C}^2 &\longrightarrow Y_{\mathcal{A}} \\ (s, t) &\longmapsto (s, st, t^2). \end{aligned}$$

This map is one-to-one on the torus (the torus of $Y_{\mathcal{A}}$ is normal and hence is unchanged under normalization) but not on the t -axis, since here the map is $(0, t) \mapsto (0, 0, t^2)$. We will soon see the intrinsic reason why this happens. \diamond

We now determine the orbit structure of $Y_{\mathcal{A}}$.

Theorem 3.A.3. *Let $Y_{\mathcal{A}}$ be an affine toric variety with $M = \mathbb{Z}\mathcal{A}$ and let $\sigma \subseteq N_{\mathbb{R}}$ be as above. Then:*

- (a) *There is a bijective correspondence*

$$\{\text{faces } \tau \text{ of } \sigma\} \longleftrightarrow \{T_N\text{-orbits in } Y_{\mathcal{A}}\}$$

such that a face of σ of dimension k corresponds to an orbit of dimension $\dim Y_{\mathcal{A}} - k$.

- (b) *If $O' \subseteq Y_{\mathcal{A}}$ is the orbit corresponding to a face τ of σ , then O' is the torus with character group $\mathbb{Z}(\tau^{\perp} \cap \mathcal{A})$.*

(c) *The normalization $U_\sigma \rightarrow Y_{\mathcal{A}}$ induces a bijection*

$$\{T_N\text{-orbits in } U_\sigma\} \longleftrightarrow \{T_N\text{-orbits in } Y_{\mathcal{A}}\}$$

such that if $O \subseteq U_\sigma$ and $O' \subseteq Y_{\mathcal{A}}$ are the orbits corresponding to a face τ of σ , then the induced map $O \rightarrow O'$ is the map of tori corresponding to the inclusion $\mathbb{Z}(\tau^\perp \cap \mathcal{A}) \subseteq \tau^\perp \cap M$ of character groups.

Proof. We will sketch the main ideas and leave the details for the reader. The proof uses the Orbit-Cone Correspondence (Theorem 3.2.6). We regard points of U_σ and $Y_{\mathcal{A}}$ as semi-group homomorphisms, so that $\gamma : \sigma^\vee \cap M \rightarrow \mathbb{C}$ in U_σ maps to $\gamma|_{\mathbb{N}\mathcal{A}} : \mathbb{N}\mathcal{A} \rightarrow \mathbb{C}$ in $Y_{\mathcal{A}}$. Note also that $U_\sigma \rightarrow Y_{\mathcal{A}}$ is equivariant with respect to the action of T_N .

By Lemma 3.2.5, the orbit $O(\tau) \subseteq U_\sigma$ corresponding to a face τ of σ is the torus consisting of homomorphisms $\gamma : \tau^\perp \cap M \rightarrow \mathbb{C}^*$. Thus $\tau^\perp \cap M$ is the character group of $O(\tau)$. The normalization maps this orbit onto an orbit $O'(\tau) \subseteq Y_{\mathcal{A}}$, where a point γ of $O(\tau)$ maps to its restriction to $\mathbb{N}\mathcal{A}$. Since

$$(\tau^\perp \cap M) \cap \mathbb{Z}\mathcal{A} = \tau^\perp \cap \mathbb{Z}\mathcal{A} = \mathbb{Z}(\tau^\perp \cap \mathcal{A}),$$

it follows that $\mathbb{Z}(\tau^\perp \cap \mathcal{A})$ is the character group of $O'(\tau)$. This proves part (b), and the final assertion of part (c) follows easily.

Since $\sigma^\vee \cap M$ is the saturation of $\mathbb{N}\mathcal{A}$, it follows that there is an integer $d > 0$ such that $d\sigma^\vee \cap M \subseteq \mathbb{N}\mathcal{A}$. It follows easily that $\mathbb{Z}(\tau^\perp \cap \mathcal{A})$ has finite index in $\tau^\perp \cap M$, so that

$$\dim O'(\tau) = \dim O(\tau) = \dim U_\sigma - \dim \tau = \dim Y_{\mathcal{A}} - \dim \tau,$$

proving the final assertion of part (a).

Finally, every orbit in $Y_{\mathcal{A}}$ comes from an orbit in U_σ since $U_\sigma \rightarrow Y_{\mathcal{A}}$ is onto. If orbits $O(\tau_1), O(\tau_2)$ map to the same orbit of $Y_{\mathcal{A}}$, then

$$\mathbb{Z}(\tau_1^\perp \cap \mathcal{A}) = \mathbb{Z}(\tau_2^\perp \cap \mathcal{A}).$$

This implies $\tau_1^\perp = \tau_2^\perp$, so that $\tau_1 = \tau_2$. The bijections in parts (a) and (c) now follow. \square

We leave it to the reader to work out other aspects of the Orbit-Cone Correspondence (specifically, the analogs of parts (c) and (d) of Theorem 3.2.6) for $Y_{\mathcal{A}}$.

Let us apply Theorem 3.A.3 to our previous example.

Example 3.A.4. Let $\mathcal{A} = \{e_1, e_1 + e_2, 2e_2\} \subseteq \mathbb{Z}^2$ as in Example 3.A.2. The cone $\sigma = \text{Cone}(\mathcal{A})^\vee = \text{Cone}(e_1, e_2)$ has a face τ such that $\tau^\perp = \text{Span}(e_2)$. Thus

$$\begin{aligned} \mathbb{Z}(\tau^\perp \cap \mathcal{A}) &= \mathbb{Z}(2e_2) \\ \tau^\perp \cap M &= \mathbb{Z}e_2. \end{aligned}$$

It follows that $\mathbb{Z}(\tau^\perp \cap \mathcal{A})$ has index 2 in $\tau^\perp \cap M$, which explains why the normalization map is two-to-one on the orbit corresponding to τ . \diamond

We now turn to the projective case. Here, $\mathcal{A} = \{m_1, \dots, m_s\} \subseteq M$ gives the projective toric variety $X_{\mathcal{A}} \subseteq \mathbb{P}^{s-1}$ whose torus has character group $\mathbb{Z}'\mathcal{A}$ (Proposition 2.1.6). Recall that $\mathbb{Z}'\mathcal{A} = \{\sum_{i=1}^s a_i m_i \mid a_i \in \mathbb{Z}, \sum_{i=1}^s a_i = 0\}$.

One observation is that translating \mathcal{A} by $m \in M$ leaves the corresponding projective variety unchanged. In other words, $X_{m+\mathcal{A}} = X_{\mathcal{A}}$ (see part (a) of Exercise 2.1.6). Thus, by

translating an element of \mathcal{A} to the origin, we may assume $0 \in \mathcal{A}$. Note that the torus of $X_{\mathcal{A}}$ has character lattice $\mathbb{Z}^{\mathcal{A}} = \mathbb{Z}\mathcal{A}$ when $0 \in \mathcal{A}$.

We defined the normalization of an affine variety in §1.0. Using a gluing construction, one can define the normalization of any variety (see [77, Ex. II.3.8]). We can describe the normalization of a projective toric variety $X_{\mathcal{A}}$ as follows.

Theorem 3.A.5. *Let $X_{\mathcal{A}}$ be a projective toric variety where $0 \in \mathcal{A}$ and $M = \mathbb{Z}\mathcal{A}$. If $P = \text{Conv}(\mathcal{A}) \subseteq M_{\mathbb{R}}$, then the normalization of $X_{\mathcal{A}}$ is the toric variety X_{Σ_P} of the normal fan of P with respect to the lattice $N = \text{Hom}_{\mathbb{Z}}(M, \mathbb{Z})$.*

Proof. Again, we sketch the proof and leave the details to the reader. We use the local description of $X_{\mathcal{A}}$ given in Propositions 2.1.8 and 2.1.9. There, we saw that $X_{\mathcal{A}}$ has an affine open covering given by the affine toric varieties $Y_{\mathcal{A}_v} = \text{Spec}(\mathbb{N}\mathcal{A}_v)$, where $v \in \mathcal{A}$ is a vertex of $P = \text{Conv}(\mathcal{A})$ and $\mathcal{A}_v = \mathcal{A} - v = \{m - v \mid m \in \mathcal{A}\}$.

For the moment, assume that P is very ample. Then Theorem 2.3.1 implies that X_P has an affine open cover given by the affine toric varieties $U_{\sigma_v} = \text{Spec}(\sigma_v^{\vee} \cap M)$, where $v \in \mathcal{A}$ is a vertex of P and $\sigma_v^{\vee} = \text{Cone}(P \cap M - v)$. One can check that $\sigma_v^{\vee} \cap M$ is the saturation of $\mathbb{N}\mathcal{A}_v$, so that U_{σ_v} is the normalization of $Y_{\mathcal{A}_v}$. The gluings are also compatible by equations (2.1.6), (2.1.7) and Proposition 2.3.12. It follows that we get a natural map $X_{\Sigma_P} \rightarrow X_{\mathcal{A}}$ that is the normalization of $X_{\mathcal{A}}$.

In the general case, we note that k_0P is very ample for some integer $k_0 \geq 1$ and that P and k_0P have the same normal fan. Since σ_v is a maximal cone of the normal fan, the above argument now applies in general, and the theorem is proved. \square

Combining this result with the Orbit-Cone Correspondence and Theorem 3.A.3 gives the following immediate corollary.

Corollary 3.A.6. *With the same hypotheses as Theorem 3.A.5, we have:*

(a) *There is a bijective correspondence*

$$\{\text{cones } \tau \text{ of } \Sigma_P\} \longleftrightarrow \{T_N\text{-orbits in } X_{\mathcal{A}}\}$$

such that a cone τ of dimension k corresponds to an orbit of dimension $\dim X_{\mathcal{A}} - k$.

(b) *If $O' \subseteq X_{\mathcal{A}}$ is the orbit corresponding to a cone τ of Σ_P , then O' is the torus with character group $\mathbb{Z}(\tau^{\perp} \cap \mathcal{A})$.*

(c) *The normalization $X_{\Sigma_P} \rightarrow X_{\mathcal{A}}$ induces a bijection*

$$\{T_N\text{-orbits in } X_{\Sigma_P}\} \longleftrightarrow \{T_N\text{-orbits in } X_{\mathcal{A}}\}$$

such that if $O \subseteq X_{\Sigma_P}$ and $O' \subseteq X_{\mathcal{A}}$ are the orbits corresponding to $\tau \in \Sigma_P$, then the induced map $O \rightarrow O'$ is the map of tori corresponding to the inclusion $\mathbb{Z}(\tau^{\perp} \cap \mathcal{A}) \subseteq \tau^{\perp} \cap M$ of character groups.

We leave it to the reader to work out other aspects of the Orbit-Cone Correspondence for $X_{\mathcal{A}}$. A different approach to the study of $X_{\mathcal{A}}$ appears in [62, Ch. 5].

Divisors on Toric Varieties

§4.0. Background: Valuations, Divisors and Sheaves

Divisors are defined in terms of irreducible codimension one subvarieties. In this chapter, we will consider *Weil divisors* and *Cartier divisors*. These classes coincide on a smooth variety, but for a normal variety, the situation is more complicated. We will also study *divisor classes*, which are defined using the order of vanishing of a rational function on an irreducible divisor. We will see that normal varieties are the natural setting to develop a theory of divisors and divisor classes.

First, we give a simple motivational example.

Example 4.0.1. If $f(x) \in \mathbb{C}(x)$ is nonzero, then there is a unique $n \in \mathbb{Z}$ such that $f(x) = x^n \frac{g(x)}{h(x)}$, where $g(x), h(x) \in \mathbb{C}[x]$ are not divisible by x . This works because $\mathbb{C}[x]$ is a UFD. The integer n describes the behavior of $f(x)$ at 0: if $n > 0$, $f(x)$ vanishes to order n at 0, and if $n < 0$, $f(x)$ has a pole of order $|n|$ at 0. Furthermore, the map from the multiplicative group $\mathbb{C}(x)^*$ to the additive group \mathbb{Z} defined by $f(x) \mapsto n$ is easily seen to be a group homomorphism. This works in the same way if we replace 0 with any point of \mathbb{C} . \diamond

Discrete Valuation Rings. The simple construction given in Example 4.0.1 applies in far greater generality. We begin by reviewing the algebraic machinery we will need.

Definition 4.0.2. A *discrete valuation* on a field K is a group homomorphism

$$\nu : K^* \longrightarrow \mathbb{Z}$$

that is onto and satisfies $\nu(x+y) \geq \min(\nu(x), \nu(y))$ when $x, y, x+y \in K^* = K \setminus \{0\}$. The corresponding *discrete valuation ring* is the ring

$$R = \{x \in K^* \mid \nu(x) \geq 0\} \cup \{0\}.$$

One can check that a DVR is indeed a ring. Here are some properties of DVRs.

Proposition 4.0.3. *Let R be a DVR with valuation $\nu : K^* \rightarrow \mathbb{Z}$. Then:*

- (a) $x \in R$ is invertible in R if and only if $\nu(x) = 0$.
- (b) R is a local ring with maximal ideal $\mathfrak{m} = \{x \in R \mid \nu(x) > 0\} \cup \{0\}$.
- (c) R is normal.
- (d) R is a principal ideal domain (PID).
- (e) R is Noetherian.
- (f) The only proper prime ideals of R are $\{0\}$ and \mathfrak{m} .

Proof. First observe that since ν is a homomorphism, we have

$$(4.0.1) \quad \nu(x^{-1}) = -\nu(x)$$

for all $x \in K^*$. If $x \in R$ is a unit, then $\nu(x), \nu(x^{-1}) \geq 0$ since $x, x^{-1} \in R$. Thus $\nu(x) = 0$ by (4.0.1). Conversely, if $\nu(x) = 0$, then $\nu(x^{-1}) = 0$ by (4.0.1), so that $x^{-1} \in R$. This proves part (a).

For part (b), note that $\mathfrak{m} = \{x \in R \mid \nu(x) > 0\} \cup \{0\}$ is an ideal of R (this follows directly from Definition 4.0.2). Then part (a) easily implies that R is local with maximal ideal \mathfrak{m} (Exercise 4.0.1).

To prove part (c), suppose $x \in K^* = K \setminus \{0\}$ satisfies

$$x^n + r_{n-1}x^{n-1} + \cdots + r_0 = 0,$$

with $r_i \in R$. If $x \in R$, we are done, so suppose $x \notin R$. Then $n > 1$ and $\nu(x) < 0$. Using (4.0.1) again, we see that $x^{-1} \in R$. So $x^{1-n} = (x^{-1})^{n-1} \in R$ and hence

$$x^{1-n} \cdot (x^n + r_{n-1}x^{n-1} + \cdots + r_0) = 0,$$

showing that $x = -(r_{n-1} + r_{n-2}x^{-1} + \cdots + r_0x^{1-n}) \in R$.

Let $\pi \in R$ satisfy $\nu(\pi) = 1$ and let $I \neq \{0\}$ be an ideal of R . Pick $x \in I \setminus \{0\}$ with $k = \nu(x)$ minimal. Then $y = x\pi^{-k} \in K$ satisfies $\nu(y) = \nu(x) - k\nu(\pi) = 0$, so that y is invertible in R . From here, one proves without difficulty that $I = \langle \pi^k \rangle$. This proves part (d), and part (e) follows immediately.

For part (f), it is obvious that $\{0\}$ and the maximal ideal \mathfrak{m} are prime. Note also that $\mathfrak{m} = \langle \pi \rangle$. Now let $P \neq \{0\}$ be a proper prime ideal. By the previous paragraph, $P = \langle \pi^k \rangle$ for some $k > 0$. If $k > 1$, then $\pi \cdot \pi^{k-1} \in P$ and $\pi, \pi^{k-1} \notin P$ give a contradiction. \square

This shows that every DVR is a Noetherian local domain of dimension one. In general, the *dimension* $\dim R$ of a Noetherian ring R is one less than the length of the longest chain $P_0 \subsetneq \cdots \subsetneq P_d$ of proper prime ideals contained in R . Among Noetherian local domains of dimension one, DVRs are characterized as follows.

Theorem 4.0.4. *If (R, \mathfrak{m}) is a Noetherian local domain of dimension one, then the following are equivalent.*

- (a) R is a DVR.
- (b) R is normal.
- (c) \mathfrak{m} is principal.
- (d) (R, \mathfrak{m}) is a regular local ring.

Proof. The implications (a) \Rightarrow (b) and (a) \Rightarrow (c) follow from Proposition 4.0.3, and the equivalence (c) \Leftrightarrow (d) is covered in Exercise 4.0.2. The remaining implications can be found in [3, Prop. 9.2]. \square

DVRs and Prime Divisors. DVRs have a natural geometric interpretation. Let X be an irreducible variety. A *prime divisor* $D \subseteq X$ is an irreducible subvariety of codimension one, meaning that $\dim D = \dim X - 1$. Recall from §3.0 that X has a field of rational functions $\mathbb{C}(X)$. Our goal is to define a ring $\mathcal{O}_{X,D}$ with field of fractions $\mathbb{C}(X)$ such that $\mathcal{O}_{X,D}$ is a DVR when X is normal. This will give a valuation $\nu_D : \mathbb{C}(X)^* \rightarrow \mathbb{Z}$ such that for $f \in \mathbb{C}(X)^*$, $\nu_D(f)$ gives the order of vanishing of f along D .

Definition 4.0.5. For a variety X and prime divisor $D \subseteq X$, $\mathcal{O}_{X,D}$ is the subring of $\mathbb{C}(X)$ defined by

$$\mathcal{O}_{X,D} = \{\phi \in \mathbb{C}(X) \mid \phi \text{ is defined on } U \subseteq X \text{ open with } U \cap D \neq \emptyset\}.$$

We will see below that $\mathcal{O}_{X,D}$ is a ring. Intuitively, this ring is built from rational functions on X that are defined somewhere on D (and hence defined on most of D since D is irreducible).

Since X is irreducible, Exercise 3.0.4 implies that $\mathbb{C}(X) = \mathbb{C}(U)$ whenever $U \subseteq X$ is open and nonempty. If we further assume that $U \cap D$ is nonempty, then

$$(4.0.2) \quad \mathcal{O}_{X,D} = \mathcal{O}_{U,U \cap D}$$

follows easily (Exercise 4.0.3).

Hence we can reduce to the affine case $X = \text{Spec}(R)$ for an integral domain R . The *codimension* of a prime ideal \mathfrak{p} , also called its *height*, is defined to be $\text{codim } \mathfrak{p} = \dim R - \dim \mathbf{V}(\mathfrak{p})$. It follows easily that $\mathfrak{p} \mapsto \mathbf{V}(\mathfrak{p})$ induces a bijection

$$\{\text{codimension one prime ideals of } R\} \simeq \{\text{prime divisors of } X\}.$$

Given a prime divisor $D = \mathbf{V}(\mathfrak{p})$, we can interpret $\mathcal{O}_{X,D}$ in terms of R as follows. The field of rational functions $\mathbb{C}(X)$ is the field of fractions K of R , and a rational function $\phi = f/g \in K$, $f, g \in R$, is defined somewhere on $D = \mathbf{V}(\mathfrak{p})$ precisely when $g \notin \mathbf{I}(D) = \mathfrak{p}$. It follows that

$$\mathcal{O}_{X,D} = \{f/g \in K \mid f, g \in R, g \notin \mathfrak{p}\},$$

which is the localization $R_{\mathfrak{p}}$ of R at the multiplicative subset $R \setminus \mathfrak{p}$ (note that $R \setminus \mathfrak{p}$ is closed under multiplication because \mathfrak{p} is prime). This localization is a local ring with maximal ideal $\mathfrak{p}R_{\mathfrak{p}}$ (Exercise 4.0.3). It follows that

$$(4.0.3) \quad \mathcal{O}_{X,D} = R_{\mathfrak{p}}$$

when $X = \text{Spec}(R)$ and \mathfrak{p} is a codimension one prime ideal of R .

Example 4.0.6. In Example 4.0.1, we constructed a discrete valuation on $\mathbb{C}(x)$ by sending $f(x) \in \mathbb{C}(x)^*$ to $n \in \mathbb{Z}$, provided

$$f(x) = x^n \frac{g(x)}{h(x)}, \quad g(x), h(x) \in \mathbb{C}[x], \quad g(0), h(0) \neq 0.$$

The corresponding DVR is the localization $\mathbb{C}[x]_{(x)}$. It follows that the prime divisor $\{0\} = \mathbf{V}(x) \subseteq \mathbb{C} = \text{Spec}(\mathbb{C}[x])$ has the local ring

$$\mathcal{O}_{\mathbb{C},\{0\}} = \mathbb{C}[x]_{(x)}$$

which is a DVR. ◇

More generally, a normal ring or variety gives a DVR as follows.

Proposition 4.0.7.

- (a) *Let R be a normal domain and $\mathfrak{p} \subseteq R$ be a codimension one prime ideal. Then the localization $R_{\mathfrak{p}}$ is a DVR.*
- (b) *Let X be a normal variety and $D \subseteq X$ a prime divisor. Then the local ring $\mathcal{O}_{X,D}$ is a DVR.*

Proof. By Proposition 3.0.12, part (b) follows immediately from part (a) together with (4.0.2) and (4.0.3).

It remains to prove part (a). The maximal ideal of $R_{\mathfrak{p}}$ is the ideal $\mathfrak{m}_{\mathfrak{p}} = \mathfrak{p}R_{\mathfrak{p}}$ generated by \mathfrak{p} in $R_{\mathfrak{p}}$. The localization of a Noetherian ring is Noetherian (Exercise 4.0.4), and the same is true for normality by Exercise 1.0.7. It follows that the local domain $(R_{\mathfrak{p}}, \mathfrak{m}_{\mathfrak{p}})$ is Noetherian and normal.

We compute the dimension of $R_{\mathfrak{p}}$ as follows. Since $\dim X = \dim R$ (see [35, Ex. 17 and 18 of Ch. 9, §4]), our hypothesis on $D = \mathbf{V}(\mathfrak{p})$ implies that there are no prime ideals strictly between $\{0\}$ and \mathfrak{p} in R . By [3, Prop. 3.11], the same is true for $\{0\}$ and $\mathfrak{m}_{\mathfrak{p}}$ in $R_{\mathfrak{p}}$. It follows that $R_{\mathfrak{p}}$ has dimension one. Then $R_{\mathfrak{p}}$ is a DVR by Theorem 4.0.4. □

When D is a prime divisor on a normal variety X , the DVR $\mathcal{O}_{X,D}$ means that we have a discrete valuation

$$\nu_D : \mathbb{C}(X)^* \longrightarrow \mathbb{Z}.$$

Given $f \in \mathbb{C}(X)^*$, we call $\nu_D(f)$ the *order of vanishing* of f along the divisor D . Thus the local ring $\mathcal{O}_{X,D}$ consists of those rational functions whose order of vanishing along D is ≥ 0 , and its maximal ideal $\mathfrak{m}_{X,D}$ consists of those rational

functions that vanish on D . When $\nu_D(f) = n < 0$, we say that f has a *pole* of order $|n|$ along D .

Weil Divisors. Recall that a prime divisor on an irreducible variety X is an irreducible subvariety of codimension one.

Definition 4.0.8. $\text{Div}(X)$ is the free abelian group generated by the prime divisors on X . A **Weil divisor** is an element of $\text{Div}(X)$.

Thus a Weil divisor $D \in \text{Div}(X)$ is a finite sum $D = \sum_i a_i D_i \in \text{Div}(X)$ of prime divisors D_i with $a_i \in \mathbb{Z}$ for all i . The divisor D is *effective*, written $D \geq 0$, if the a_i are all nonnegative. The *support* of D is the union of the prime divisors appearing in D :

$$\text{Supp}(D) = \bigcup_{a_i \neq 0} D_i.$$

The Divisor of a Rational Function. An important class of Weil divisors comes from rational functions. If X is normal, any prime divisor D on X corresponds to a DVR $\mathcal{O}_{X,D}$ with valuation $\nu_D : \mathbb{C}(X)^* \rightarrow \mathbb{Z}$. Given $f \in \mathbb{C}(X)^*$, the integers $\nu_D(f)$ tell us how f behaves on the prime divisors of X . Here is an important property of these integers.

Lemma 4.0.9. *If X is normal and $f \in \mathbb{C}(X)^*$, then $\nu_D(f)$ is zero for all but a finite number of prime divisors $D \subseteq X$.*

Proof. If f is constant, then it is a nonzero constant since $f \in \mathbb{C}(X)^*$. It follows that $\nu_D(f) = 0$ for all D . On the other hand, if f is nonconstant, then we can find a nonempty open subset $U \subseteq X$ such that $f : U \rightarrow \mathbb{C}$ is a nonconstant morphism. Then $V = f^{-1}(\mathbb{C}^*)$ is a nonempty open subset of X such that $f|_V : V \rightarrow \mathbb{C}^*$. The complement $X \setminus V$ is Zariski closed and hence is a union of irreducible components of dimension $< n$. Denote the irreducible components of codimension one by D_1, \dots, D_s .

Now let D be prime divisor in X . If $V \cap D = \emptyset$, then $D \subseteq X \setminus V$, so that D is contained in an irreducible component of $X \setminus V$ since D is irreducible. Dimension considerations imply that $D = D_i$ for some i . On the other hand, if $V \cap D \neq \emptyset$, then f is an invertible element of $\mathcal{O}_{X,D} = \mathcal{O}_{V,V \cap D}$, which implies that $\nu_D(f) = 0$. \square

Definition 4.0.10. Let X be a normal variety.

(a) The *divisor* of $f \in \mathbb{C}(X)^*$ is

$$\text{div}(f) = \sum_D \nu_D(f) D,$$

where the sum is over all prime divisors $D \subseteq X$.

(b) $\text{div}(f)$ is called a **principal divisor**, and the set of all principal divisors is denoted $\text{Div}_0(X)$.

(c) Divisors D and E are **linearly equivalent**, written $D \sim E$, if their difference is a principal divisor, i.e., $D - E = \operatorname{div}(f) \in \operatorname{Div}_0(X)$ for some $f \in \mathbb{C}(X)^*$.

Lemma 4.0.9 implies that $\operatorname{div}(f) \in \operatorname{Div}(X)$. If $f, g \in \mathbb{C}(X)^*$, then $\operatorname{div}(fg) = \operatorname{div}(f) + \operatorname{div}(g)$ and $\operatorname{div}(f^{-1}) = -\operatorname{div}(f)$ since valuations are group homomorphisms on $\mathbb{C}(X)^*$. It follows that $\operatorname{Div}_0(X)$ is a subgroup of $\operatorname{Div}(X)$.

Example 4.0.11. Let $f = c(x - a_1)^{m_1} \cdots (x - a_r)^{m_r} \in \mathbb{C}[x]$ be a polynomial of degree $m > 0$, where $c \in \mathbb{C}^*$ and $a_1, \dots, a_r \in \mathbb{C}$ are distinct. Then:

- When $X = \mathbb{C}$, $\operatorname{div}(f) = \sum_{i=1}^r m_i \{a_i\}$.
- When $X = \mathbb{P}^1 = \mathbb{C} \cup \{\infty\}$, $\operatorname{div}(f) = \sum_{i=1}^r m_i \{a_i\} - m \{\infty\}$. ◇

The divisor of $f \in \mathbb{C}(X)^*$ can be written $\operatorname{div}(f) = \operatorname{div}_0(f) - \operatorname{div}_\infty(f)$, where

$$\begin{aligned} \operatorname{div}_0(f) &= \sum_{\nu_D(f) > 0} \nu_D(f) D \\ \operatorname{div}_\infty(f) &= \sum_{\nu_D(f) < 0} -\nu_D(f) D. \end{aligned}$$

We call $\operatorname{div}_0(f)$ the *divisor of zeros* of f and $\operatorname{div}_\infty(f)$ the *divisor of poles* of f . Note that these are effective divisors.

Cartier Divisors. If $D = \sum_i a_i D_i$ is a Weil divisor on X and $U \subseteq X$ is a nonempty open subset, then

$$D|_U = \sum_{U \cap D_i \neq \emptyset} a_i U \cap D_i$$

is a Weil divisor on U called the *restriction* of D to U .

We now define a special class of Weil divisors.

Definition 4.0.12. A Weil divisor D on a normal variety X is **Cartier** if it is **locally principal**, meaning that X has an open cover $\{U_i\}_{i \in I}$ such that $D|_{U_i}$ is principal in U_i for every $i \in I$. If $D|_{U_i} = \operatorname{div}(f_i)|_{U_i}$ for $i \in I$, then we call $\{(U_i, f_i)\}_{i \in I}$ the **local data** for D .

A principal divisor is obviously locally principal. Thus $\operatorname{div}(f)$ is Cartier for all $f \in \mathbb{C}(X)^*$. One can also show that if D and E are Cartier divisors, then $D + E$ and $-D$ are Cartier (Exercise 4.0.5). It follows that the Cartier divisors on X form a group $\operatorname{CDiv}(X)$ satisfying

$$\operatorname{Div}_0(X) \subseteq \operatorname{CDiv}(X) \subseteq \operatorname{Div}(X).$$

Divisor Classes. For Weil and Cartier divisors, linear equivalence classes form the following important groups

Definition 4.0.13. Let X be a normal variety. Its *class group* is

$$\mathrm{Cl}(X) = \mathrm{Div}(X)/\mathrm{Div}_0(X),$$

and its *Picard group* is

$$\mathrm{Pic}(X) = \mathrm{CDiv}(X)/\mathrm{Div}_0(X).$$

We will give a more sophisticated definition of $\mathrm{Pic}(X)$ in Chapter 6. Note that since $\mathrm{CDiv}(X)$ is a subgroup of $\mathrm{Div}(X)$, we get a canonical injection

$$\mathrm{Pic}(X) \hookrightarrow \mathrm{Cl}(X).$$

In [77, II.6], Hartshorne writes “The divisor class group of a scheme is a very interesting invariant. In general it is not easy to calculate.” Fortunately, divisor class groups of normal toric varieties are easy to describe, as we will see in §4.1.

More Algebra. Before we can derive further properties of divisors, we need to learn more about normal domains. Equation (3.0.2) shows that if $X = \mathrm{Spec}(R)$ is irreducible, then

$$R = \bigcap_{p \in X} \mathcal{O}_{X,p}.$$

If a point $p \in X$ corresponds to a maximal ideal $\mathfrak{m} \subseteq R$, then the local ring $\mathcal{O}_{X,p}$ is the localization $R_{\mathfrak{m}}$. Hence the above equality can be written

$$R = \bigcap_{\mathfrak{m} \text{ maximal}} R_{\mathfrak{m}}.$$

When R is normal, we get a similar result using codimension one prime ideals.

Theorem 4.0.14. *If R is a Noetherian normal domain, then*

$$R = \bigcap_{\mathrm{codim} \mathfrak{p}=1} R_{\mathfrak{p}}.$$

Proof. Let K be the field of fractions of R and assume that $a/b \in K$, $a, b \in R$, lies in $R_{\mathfrak{p}}$ for all codimension one prime ideals \mathfrak{p} . It suffices to prove that $a \in \langle b \rangle$. This is obviously true when b is invertible in R , so we may assume that $\langle b \rangle$ is a proper ideal of R . Then we have a primary decomposition (see [35, Ch. 4, §7])

$$(4.0.4) \quad \langle b \rangle = \mathfrak{q}_1 \cap \cdots \cap \mathfrak{q}_s,$$

and each prime ideal $\mathfrak{p}_i = \sqrt{\mathfrak{q}_i}$ is of the form $\mathfrak{p}_i = \langle b \rangle : c_i$ for some $c_i \in R$. In the terminology of [118, p. 38], the \mathfrak{p}_i are the *prime divisors* of $\langle b \rangle$.

Since R is Noetherian and normal, the Krull Principal Ideal Theorem states that every prime divisor of $\langle b \rangle$ has codimension one (see [118, Thm. 11.5] for a proof). This implies that in the primary decomposition (4.0.4), the prime divisors \mathfrak{p}_i have codimension one and hence are distinct.

Note that $a/b \in R_{\mathfrak{p}_i}$ for all i by our assumption on a/b . This implies $a \in bR_{\mathfrak{p}_i}$. Since $(\mathfrak{q}_j)_{\mathfrak{p}_i} = R_{\mathfrak{p}_i}$ for $j \neq i$ (Exercise 4.0.6), localizing (4.0.4) at \mathfrak{p}_i shows that for all i , we have

$$a \in bR_{\mathfrak{p}_i} = \mathfrak{q}_i R_{\mathfrak{p}_i}.$$

Since $\mathfrak{q}_i R_{\mathfrak{p}_i} \cap R = \mathfrak{q}_i$ (Exercise 4.0.6), we obtain $a \in \bigcap_{i=1}^s \mathfrak{q}_i = \langle b \rangle$. \square

This result has the following useful corollary.

Corollary 4.0.15. *Let X be a normal variety and let $f : U \rightarrow \mathbb{C}$ be a morphism defined on an open set $U \subseteq X$. If $X \setminus U$ has codimension ≥ 2 in X , then f extends to a morphism defined on all of X .*

Proof. Since X has an affine open cover, we can assume that $X = \text{Spec}(R)$, where R is a Noetherian normal domain. If $D \subseteq X$ is a prime divisor, then $U \cap D \neq \emptyset$ for dimension reasons. It follows that $f \in \mathcal{O}_{U, U \cap D} = \mathcal{O}_{X, D}$, so that

$$(4.0.5) \quad f \in \bigcap_D \mathcal{O}_{U, U \cap D} = \bigcap_D \mathcal{O}_{X, D} = \bigcap_{\text{codim } \mathfrak{p}=1} R_{\mathfrak{p}} = R,$$

where the final equality is Theorem 4.0.14. \square

These results enable us to determine when the divisor of a rational function is effective.

Proposition 4.0.16. *Let X be a normal variety. If $f \in \mathbb{C}(X)^*$, then:*

- (a) $\text{div}(f) \geq 0$ if and only if $f : X \rightarrow \mathbb{C}$ is a morphism, i.e., $f \in \mathcal{O}_X(X)$.
- (b) $\text{div}(f) = 0$ if and only if $f : X \rightarrow \mathbb{C}^*$ is a morphism, i.e., $f \in \mathcal{O}_X^*(X)$.

In general, \mathcal{O}_X^* is the sheaf on X defined by

$$\mathcal{O}_X^*(U) = \{\text{invertible elements of } \mathcal{O}_X(U)\}.$$

This is a sheaf of abelian groups under multiplication.

Proof. If $f : X \rightarrow \mathbb{C}$ is a morphism, then $f \in \mathcal{O}_{X, D}$ for every prime divisor D , which in turn implies $\nu_D(f) \geq 0$. Hence $\text{div}(f) \geq 0$. Going the other way, suppose that $\text{div}(f) \geq 0$. This remains true when we restrict to an affine open subset, so we may assume that X is affine. Then $\text{div}(f) \geq 0$ implies

$$f \in \bigcap_D \mathcal{O}_{X, D},$$

where the intersection is over all prime divisors. By (4.0.5), we conclude that f is defined everywhere. This proves part (a), and part (b) follows immediately since $\text{div}(f) = 0$ if and only if $\text{div}(f) \geq 0$ and $\text{div}(f^{-1}) \geq 0$. \square

Singularities and Normality. The set of singular points of a variety X is denoted

$$\text{Sing}(X) \subseteq X.$$

We call $\text{Sing}(X)$ the *singular locus* of X . One can show that $\text{Sing}(X)$ is a proper closed subvariety of X (see [77, Thm. I.5.3]). When X is normal, things are even nicer.

Proposition 4.0.17. *Let X be a normal variety. Then:*

- (a) $\text{Sing}(X)$ has codimension ≥ 2 in X .
- (b) If X is a curve, then X is smooth.

Proof. You will prove part (b) in Exercise 4.0.7. A proof of part (a) can be found in [152, Vol. 2, Thm. 3 of §II.5]. \square

Computing Divisor Classes. There are two results, one algebraic and one geometric, that enable us to compute class groups in some cases.

We begin with the algebraic result.

Theorem 4.0.18. *Let R be a UFD and set $X = \text{Spec}(R)$. Then:*

- (a) R is normal and every codimension one prime ideal is principal.
- (b) $\text{Cl}(X) = 0$.

Proof. For part (a), we know that a UFD is normal by Exercise 1.0.5. Let \mathfrak{p} be a codimension one prime ideal of R and pick $a \in \mathfrak{p} \setminus \{0\}$. Since R is a UFD,

$$a = c \prod_{i=1}^s p_i^{a_i},$$

with the p_i prime and c is invertible in R . Because \mathfrak{p} is prime, this means some $p_i \in \mathfrak{p}$, and since $\text{codim } \mathfrak{p} = 1$, this forces $\mathfrak{p} = \langle p_i \rangle$.

Turning to part (b), let $D \subseteq X$ be a prime divisor. Then $\mathfrak{p} = \mathbf{I}(D)$ is a codimension one prime ideal and hence is principal, say $\mathfrak{p} = \langle f \rangle$. Then f generates the maximal ideal of the DVR $R_{\mathfrak{p}}$, which implies $\nu_D(f) = 1$ (see the proof of Proposition 4.0.3). It follows easily that $\text{div}(f) = D$. Then $\text{Cl}(X) = 0$ since all prime divisors are linearly equivalent to 0. \square

In fact, more is true: a normal Noetherian domain is a UFD if and only if every codimension one prime ideal is principal (Exercise 4.0.8).

Example 4.0.19. $\mathbb{C}[x_1, \dots, x_n]$ is a UFD, so $\text{Cl}(\mathbb{C}^n) = 0$ by Theorem 4.0.18. \diamond

Before stating the geometric result, note that if $U \subseteq X$ is open and nonempty, then restriction of divisors $D \mapsto D|_U$ induces a well-defined map $\text{Cl}(X) \rightarrow \text{Cl}(U)$ (Exercise 4.0.9).

Theorem 4.0.20. *Let U be a nonempty open subset of a normal variety X and let D_1, \dots, D_s be the irreducible components of $X \setminus U$ that are prime divisors. Then the sequence*

$$\bigoplus_{j=1}^s \mathbb{Z}D_j \longrightarrow \text{Cl}(X) \longrightarrow \text{Cl}(U) \longrightarrow 0$$

is exact, where the first map sends $\sum_{j=1}^s a_j D_j$ to its divisor class in $\text{Cl}(X)$ and the second is induced by restriction to U .

Proof. Let $D' = \sum_i a_i D'_i \in \text{Div}(U)$ with D'_i a prime divisor in U . Then the Zariski closure $\overline{D'_i}$ of D'_i in X is a prime divisor in X , and $D = \sum_i a_i \overline{D'_i}$ satisfies $D|_U = D'$. Hence $\text{Cl}(X) \rightarrow \text{Cl}(U)$ is surjective.

Since each D_j restricts to 0 in $\text{Div}(U)$, the composition of the two maps is trivial. To finish the proof of exactness, suppose that $[D] \in \text{Cl}(X)$ restricts to 0 in $\text{Cl}(U)$. This means that $D|_U$ is the divisor of some $f \in \mathbb{C}(U)^*$. Since $\mathbb{C}(U) = \mathbb{C}(X)$ and the divisor of f in $\text{Div}(X)$ restricts to the divisor of f in $\text{Div}(U)$, it follows that we have $f \in \mathbb{C}(X)^*$ such that

$$D|_U = \text{div}(f)|_U.$$

This implies that the difference $D - \text{div}(f)$ is supported on $X \setminus U$, which means that $D - \text{div}(f) \in \bigoplus_{j=1}^s \mathbb{Z}D_j$ by the definition of the D_j . \square

Example 4.0.21. Write $\mathbb{P}^1 = \mathbb{C} \cup \{\infty\}$ and note that $\{\infty\}$ is a prime divisor on \mathbb{P}^1 . Then Theorem 4.0.20 and Example 4.0.21 give the exact sequence

$$\mathbb{Z}\{\infty\} \longrightarrow \text{Cl}(\mathbb{P}^1) \longrightarrow \text{Cl}(\mathbb{C}) = 0.$$

Hence the map $\mathbb{Z} \rightarrow \text{Cl}(\mathbb{P}^1)$ defined by $a \mapsto [a\{\infty\}]$ is surjective. This map is injective since $a\{\infty\} = \text{div}(f)$ implies $\text{div}(f)|_{\mathbb{C}} = 0$, so that $f \in \Gamma(\mathbb{C}, \mathcal{O}_{\mathbb{C}})^* = \mathbb{C}^*$ by Proposition 4.0.16. Hence f is constant, which forces $a = 0$. It follows that $\text{Cl}(\mathbb{P}^1) \simeq \mathbb{Z}$. \diamond

Later in the chapter we will use similar methods to compute the class group of an arbitrary normal toric variety.

Comparing Weil and Cartier Divisors. Once we understand Cartier divisors on normal toric varieties, it will be easy to give examples of Weil divisors that are not Cartier. On the other hand, there are varieties where *every* Weil divisor is Cartier.

Theorem 4.0.22. *Let X be a normal variety. Then:*

- (a) *If the local ring $\mathcal{O}_{X,p}$ is a UFD for every $p \in X$, then every Weil divisor on X is Cartier.*
- (b) *If X is smooth, then every Weil divisor on X is Cartier.*

Proof. If X is smooth, then $\mathcal{O}_{X,p}$ is a regular local ring for all $p \in X$. Since every regular local ring is a UFD (see §1.0), part (b) follows from part (a).

For part (a), it suffices to show that prime divisors are locally principal. This condition is obviously local on X , so we may assume that $X = \text{Spec}(R)$ is affine. Let $D = \mathbf{V}(\mathfrak{p})$ be a prime divisor on X , where $\mathfrak{p} \subseteq R$ is a codimension one prime ideal. Note that D is obviously principal on $U = X \setminus D$ since $D|_U = 0$. It remains to show that D is locally principal in a neighborhood of a point $p \in D$.

The point p corresponds to a maximal ideal $\mathfrak{m} \subseteq R$. Thus $p \in D$ implies $\mathfrak{p} \subseteq \mathfrak{m}$. Since $\mathfrak{p} \subseteq R$ has codimension one, it follows that the prime ideal $\mathfrak{p}R_{\mathfrak{m}} \subseteq R_{\mathfrak{m}}$ also has codimension one (this follows from [3, Prop. 3.11]). Then Theorem 4.0.18 implies that $\mathfrak{p}R_{\mathfrak{m}}$ is principal since $R_{\mathfrak{m}}$ is a UFD by hypothesis. Thus $\mathfrak{p}R_{\mathfrak{m}} = (a/b)R_{\mathfrak{m}}$ where $a, b \in R$ and $b \notin \mathfrak{m}$. Since b is invertible in $R_{\mathfrak{m}}$, we in fact have $\mathfrak{p}R_{\mathfrak{m}} = aR_{\mathfrak{m}}$.

Now suppose $\mathfrak{p} = \langle a_1, \dots, a_s \rangle \subseteq R$. Then $a_i \in \mathfrak{p}R_{\mathfrak{m}} = aR_{\mathfrak{m}}$, so that $a_i = (g_i/h_i)a$, where $g_i, h_i \in R$ and $h_i \notin \mathfrak{m}$, i.e., $h_i(p) \neq 0$. If we set $h = h_1 \cdots h_s$, then $\mathfrak{p}R_h = aR_h$ follows easily. Then $U = \text{Spec}(R_h)$ is a neighborhood of p , and from here, it is straightforward to see that $D = \text{div}(a)$ on U . \square

Example 4.0.23. Since \mathbb{P}^1 is smooth, Theorem 4.0.22 and Example 4.0.21 imply that $\text{Pic}(\mathbb{P}^1) = \text{Cl}(\mathbb{P}^1) \simeq \mathbb{Z}$. \diamond

Sheaves of \mathcal{O}_X -modules. Weil and Cartier divisors on X lead to some important sheaves on X . Hence we need a brief excursion into sheaf theory (we will go deeper into the subject in Chapter 6). The sheaf \mathcal{O}_X was defined in §3.0. The definition of a sheaf \mathcal{F} of \mathcal{O}_X -modules is similar: for each open subset $U \subseteq X$, there is an $\mathcal{O}_X(U)$ -module $\mathcal{F}(U)$ with the following properties:

- When $W \subseteq U$, there is a restriction map

$$\rho_{U,W} : \mathcal{F}(U) \rightarrow \mathcal{F}(W)$$

such that $\rho_{U,U}$ is the identity and $\rho_{V,W} \circ \rho_{U,V} = \rho_{U,W}$ when $W \subseteq V \subseteq U$. Furthermore, $\rho_{U,W}$ is compatible with the restriction map $\mathcal{O}_X(U) \rightarrow \mathcal{O}_X(W)$.

- If $\{U_\alpha\}$ is an open cover of $U \subseteq X$, then the sequence

$$0 \longrightarrow \mathcal{F}(U) \longrightarrow \prod_{\alpha} \mathcal{F}(U_{\alpha}) \rightrightarrows \prod_{\alpha, \beta} \mathcal{F}(U_{\alpha} \cap U_{\beta})$$

is exact, where the second arrow is defined by the restrictions $\rho_{U,U_{\alpha}}$ and the double arrow is defined by $\rho_{U_{\alpha}, U_{\alpha} \cap U_{\beta}}$ and $\rho_{U_{\beta}, U_{\alpha} \cap U_{\beta}}$.

When $U \mapsto \mathcal{F}(U)$ satisfies just the first bullet, we say that \mathcal{F} is a *presheaf*.

Given a sheaf of \mathcal{O}_X -modules \mathcal{F} , elements of $\mathcal{F}(U)$ are called *sections of \mathcal{F} over U* . In practice, the module of sections of \mathcal{F} over $U \subseteq X$ is expressed in several ways:

$$\mathcal{F}(U) = \Gamma(U, \mathcal{F}) = H^0(U, \mathcal{F}).$$

We will use Γ in this chapter and switch to H^0 in later chapters. Traditionally, $\Gamma(X, \mathcal{F})$ is called the module of *global sections* of \mathcal{F} .

Example 4.0.24. Let $f : X \rightarrow Y$ be a morphism of varieties and let \mathcal{F} be a sheaf of \mathcal{O}_X -modules on X . The *direct image sheaf* $f_*\mathcal{F}$ on Y is defined by

$$U \longmapsto \mathcal{F}(f^{-1}(U))$$

for $U \subseteq Y$ open. Then $f_*\mathcal{F}$ is a sheaf of \mathcal{O}_Y -modules. For $i : Y \hookrightarrow X$, the direct image $i_*\mathcal{O}_Y$ was mentioned in §3.0. \diamond

If \mathcal{F} and \mathcal{G} are sheaves of \mathcal{O}_X -modules, then a *homomorphism of sheaves* $\phi : \mathcal{F} \rightarrow \mathcal{G}$ consists of $\mathcal{O}_X(U)$ -module homomorphisms

$$\phi_U : \mathcal{F}(U) \longrightarrow \mathcal{G}(U),$$

such that the diagram

$$\begin{array}{ccc} \mathcal{F}(U) & \xrightarrow{\phi_U} & \mathcal{G}(U) \\ \downarrow \rho_{U,V} & & \downarrow \rho_{U,V} \\ \mathcal{F}(V) & \xrightarrow{\phi_V} & \mathcal{G}(V) \end{array}$$

commutes whenever $V \subseteq U$. It should be clear what it means for sheaves \mathcal{F}, \mathcal{G} of \mathcal{O}_X -modules to be isomorphic, written $\mathcal{F} \simeq \mathcal{G}$.

Example 4.0.25. Let $f : X \rightarrow Y$ be a morphism of varieties. If $U \subseteq Y$ is open, then composition with f induces a natural map

$$\mathcal{O}_Y(U) \longrightarrow \mathcal{O}_X(f^{-1}(U)) = f_*\mathcal{O}_X(U).$$

This defines a sheaf homomorphism $\mathcal{O}_Y \rightarrow f_*\mathcal{O}_X$. \diamond

Over an affine variety $X = \text{Spec}(R)$, there is a standard way to get sheaves of \mathcal{O}_X -modules. Recall that a nonzero element $f \in R$ gives the localization R_f such that $X_f = \text{Spec}(R_f)$ is the open subset $X \setminus \mathbf{V}(f)$. Given an R -module M , we get the R_f -module $M_f = M \otimes_R R_f$. Then there is a unique sheaf \tilde{M} of \mathcal{O}_X -modules such that

$$\tilde{M}(X_f) = M_f$$

for every nonzero $f \in R$. This is proved in [77, Prop. II.5.1].

We globalize this construction as follows.

Definition 4.0.26. A sheaf \mathcal{F} of \mathcal{O}_X -modules on a variety X is *quasicoherent* if X has an affine open cover $\{U_\alpha\}$, $U_\alpha = \text{Spec}(R_\alpha)$, such that for each α , there is an R_α -module M_α satisfying $\mathcal{F}|_{U_\alpha} \simeq \tilde{M}_\alpha$. Furthermore, if each M_α is a finitely generated R_α -module, then we say that \mathcal{F} is *coherent*.

The Sheaf of a Weil Divisor. Let D be a Weil divisor on a normal variety X . We will show that D determines a sheaf $\mathcal{O}_X(D)$ of \mathcal{O}_X -modules on X . Recall that if $U \subseteq X$ is open, then $\mathcal{O}_X(U)$ consists of all morphisms $U \rightarrow \mathbb{C}$. Proposition 4.0.16 tells us that an arbitrary element $f \in \mathbb{C}(X)^*$ is a morphism on U if and only if $\operatorname{div}(f)|_U \geq 0$. It follows that the sheaf \mathcal{O}_X is defined by

$$U \longmapsto \mathcal{O}_X(U) = \{f \in \mathbb{C}(X)^* \mid \operatorname{div}(f)|_U \geq 0\} \cup \{0\}.$$

In a similar way, we define the sheaf $\mathcal{O}_X(D)$ by

$$(4.0.6) \quad U \longmapsto \mathcal{O}_X(D)(U) = \{f \in \mathbb{C}(X)^* \mid (\operatorname{div}(f) + D)|_U \geq 0\} \cup \{0\}.$$

Proposition 4.0.27. *Let D be a Weil divisor on a normal variety X . Then the sheaf $\mathcal{O}_X(D)$ defined in (4.0.6) is a coherent sheaf of \mathcal{O}_X -modules on X .*

Proof. In Exercise 4.0.10 you will show that $\mathcal{O}_X(D)$ is a sheaf of \mathcal{O}_X -modules. The proof is a nice application of the properties of valuations.

To show that $\mathcal{O}_X(D)$ is coherent, we may assume that $X = \operatorname{Spec}(R)$. Let K be the field of fractions of R . It suffices to prove the following two assertions:

- $M = \Gamma(X, \mathcal{O}_X(D)) = \{f \in K \mid \operatorname{div}(f) + D \geq 0\} \cup \{0\}$ is a finitely generated R -module.
- $\Gamma(X_f, \mathcal{O}_X(D)) = M_f$ for all nonzero $f \in R$.

For the first bullet, we will prove the existence of an element $h \in R \setminus \{0\}$ such that $h\Gamma(X, \mathcal{O}_X(D)) \subseteq R$. This will imply that $h\Gamma(X, \mathcal{O}_X(D))$ is an ideal of R and hence has a finite basis since R is Noetherian. It will follow immediately that $\Gamma(X, \mathcal{O}_X(D))$ is a finitely generated R -module.

Write $D = \sum_{i=1}^s a_i D_i$. Since $\operatorname{supp}(D)$ is a proper subvariety of X , we can find $g \in R \setminus \{0\}$ that vanishes on each D_i . Then $\nu_{D_i}(g) > 0$ for every i , so there is $m \in \mathbb{N}$ with $m\nu_{D_i}(g) > a_i$ for all i . Since $\operatorname{div}(g) \geq 0$, it follows that $m\operatorname{div}(g) - D \geq 0$. Now let $f \in \Gamma(X, \mathcal{O}_X(D))$. Then $\operatorname{div}(f) + D \geq 0$, so that

$$\operatorname{div}(g^m f) = m\operatorname{div}(g) + \operatorname{div}(f) = m\operatorname{div}(g) - D + \operatorname{div}(f) + D \geq 0$$

since a sum of effective divisors is effective. By Proposition 4.0.16, we conclude that $g^m f \in \mathcal{O}_X(X) = R$. Hence $h = g^m \in R$ has the desired property.

To prove the second bullet, observe that $M \subseteq K$ and $f \in R \setminus 0$ imply that

$$M_f = \left\{ \frac{g}{f^m} \mid g \in \Gamma(X, \mathcal{O}_X(D)), m \geq 0 \right\}.$$

It is also easy to see that $M_f \subseteq \Gamma(X_f, \mathcal{O}_X(D))$. For the opposite inclusion, let $D = \sum_{i=1}^s a_i D_i$ and write $\{1, \dots, s\} = I \cup J$ where $D_i \cap X_f \neq \emptyset$ for $i \in I$ and $D_j \subseteq \mathbf{V}(f)$ for $j \in J$. Given $h \in \Gamma(X_f, \mathcal{O}_X(D))$, $(\operatorname{div}(h) + D)|_{X_f} \geq 0$ implies that $\nu_{D_i}(h) \geq -a_i$ for $i \in I$. There is no constraint on $\nu_{D_j}(h)$ for $j \in J$, but f vanishes on D_j for $j \in J$, so that $\nu_{D_j}(f) > 0$. Hence we can pick $m \in \mathbb{N}$ sufficiently large such that

$$m\nu_{D_j}(f) + \nu_{D_j}(h) > 0 \quad \text{for } j \in J.$$

Since $\operatorname{div}(f) \geq 0$, it follows easily that $\operatorname{div}(f^m h) + D \geq 0$ on X . Thus $g = f^m h \in \Gamma(X, \mathcal{O}_X(D))$, and then $h = g/f^m$ has the desired form. \square

The sheaves $\mathcal{O}_X(D)$ are more than just coherent; they have the additional property of being *reflexive*. Furthermore, when D is Cartier, $\mathcal{O}_X(D)$ is *invertible*. The definitions of invertible and reflexive will be given in Chapters 6 and 8 respectively.

For now, we give two results about the sheaves $\mathcal{O}_X(D)$. Here is the first.

Proposition 4.0.28. *Distinct prime divisors D_1, \dots, D_s on a normal variety X give the divisor $D = D_1 + \dots + D_s$ and the subvariety $Y = \operatorname{Supp}(D) = D_1 \cup \dots \cup D_s$. Then $\mathcal{O}_X(-D)$ is the ideal sheaf \mathcal{I}_Y of Y , i.e.,*

$$\Gamma(U, \mathcal{O}_X(-D)) = \{f \in \mathcal{O}_X(U) \mid f \text{ vanishes on } Y\}$$

for all open subsets $U \subseteq X$.

Proof. Since sheaves are local, we may assume that $X = \operatorname{Spec}(R)$. Then note that $f \in \Gamma(X, \mathcal{O}_X(-D))$ implies $\operatorname{div}(f) - D \geq 0$, so $\operatorname{div}(f) \geq D \geq 0$ since D is effective. Thus $f \in R$ by Proposition 4.0.16 and hence $\Gamma(X, \mathcal{O}_X(-D))$ is an ideal of R .

Let $\mathfrak{p}_i = \mathbf{I}(D_i) \subseteq R$ be the prime ideal of D_i . Then, for $f \in R$, we have

$$\nu_{D_i}(f) > 0 \iff f \in \mathfrak{p}_i R_{\mathfrak{p}_i} \iff f \in \mathfrak{p}_i,$$

where the last equivalence uses the easy equality $\mathfrak{p}_i R_{\mathfrak{p}_i} \cap R = \mathfrak{p}_i$. Hence $\operatorname{div}(f) \geq D$ if and only if f vanishes on D_1, \dots, D_s , and the proposition follows. \square

Linear equivalence of divisors tells us the following interesting fact about the associated sheaves.

Proposition 4.0.29. *If $D \sim E$ are linearly equivalent Weil divisors, then $\mathcal{O}_X(D)$ and $\mathcal{O}_X(E)$ are isomorphic as sheaves of \mathcal{O}_X -modules.*

Proof. By assumption, we have $D = E + \operatorname{div}(g)$ for some $g \in \mathbb{C}(X)^*$. Then

$$\begin{aligned} f \in \Gamma(X, \mathcal{O}_X(D)) &\iff \operatorname{div}(f) + D \geq 0 \\ &\iff \operatorname{div}(f) + E + \operatorname{div}(g) \geq 0 \\ &\iff \operatorname{div}(fg) + E \geq 0 \\ &\iff fg \in \Gamma(X, \mathcal{O}_X(E)). \end{aligned}$$

Thus multiplication by g induces an isomorphism $\Gamma(X, \mathcal{O}_X(D)) \simeq \Gamma(X, \mathcal{O}_X(E))$ which is clearly an isomorphism of $\Gamma(X, \mathcal{O}_X)$ -modules.

The same argument works over any Zariski open set U , and the isomorphisms are easily seen to be compatible with the restriction maps. \square

The converse of Proposition 4.0.29 is also true, i.e., an \mathcal{O}_X -module isomorphism $\mathcal{O}_X(D) \simeq \mathcal{O}_X(E)$ implies that $D \sim E$. The proof requires knowing more about the sheaves $\mathcal{O}_X(D)$ and hence will be postponed until Chapter 8.

Exercises for §4.0.

4.0.1. Complete the proof of part (b) of Proposition 4.0.3.

4.0.2. Prove (c) \Leftrightarrow (d) in Theorem 4.0.4. Hint: Let \mathfrak{m} be the maximal ideal of R . Since R has dimension one, it is regular if and only if $\mathfrak{m}/\mathfrak{m}^2$ has dimension one as a vector space over R/\mathfrak{m} . For (d) \Rightarrow (c), use Nakayama's Lemma (see [3, Props. 2.6 and 2.8]).

4.0.3. This exercise will study the rings $\mathcal{O}_{X,D}$ and $R_{\mathfrak{p}}$.

(a) Prove (4.0.2).

(b) Let \mathfrak{p} be a prime ideal of a ring R and let $R_{\mathfrak{p}}$ denote the localization of R with respect to the multiplicative subset $R \setminus \mathfrak{p}$. Prove that $R_{\mathfrak{p}}$ is a local ring and that its maximal ideal is the ideal $\mathfrak{p}R_{\mathfrak{p}} \subseteq R_{\mathfrak{p}}$ generated by \mathfrak{p} .

4.0.4. Let S be a multiplicative subset of a Noetherian ring R . Prove that the localization R_S is Noetherian.

4.0.5. Let D and E be Weil divisors on a normal variety.

(a) If D and E are Cartier, show that $D + E$ and $-D$ are also Cartier.

(b) If $D \sim E$, show that D is Cartier if and only if E is Cartier.

4.0.6. Complete the proof of Theorem 4.0.14.

4.0.7. Prove that a normal curve is smooth.

4.0.8. Let R be a Noetherian normal domain. Prove that the following are equivalent:

(a) R is a UFD.

(b) $\text{Cl}(\text{Spec}(R)) = 0$.

(c) Every codimension one prime ideal of R is principal.

Hint: For (b) \Rightarrow (c), assume that $D = \text{div}(f)$ corresponds to \mathfrak{p} . Use Theorem 4.0.14 to show $f \in R$ and use the Krull Principal Ideal Theorem to show $\langle f \rangle$ is primary in R . Then $\mathfrak{p}R_{\mathfrak{p}} = fR_{\mathfrak{p}}$ and [3, Prop. 4.8] imply $\mathfrak{p} = \langle f \rangle$. For (c) \Rightarrow (a), let $a \in R$ be noninvertible and let D_1, \dots, D_s be the codimension one irreducible components of $\mathbf{V}(a)$. If $\mathbf{I}(D_i) = \langle a_i \rangle$, compare the divisors of a and $\prod_{i=1}^s a_i^{v_{D_i}(a)}$ using Proposition 4.0.16.

4.0.9. Prove that the restriction map $D \mapsto D|_U$ induces a well-defined homomorphism $\text{Cl}(X) \rightarrow \text{Cl}(U)$.

4.0.10. Let D be a Weil divisor on a normal variety X . Prove that (4.0.6) defines a sheaf $\mathcal{O}_X(D)$ of \mathcal{O}_X -modules.

4.0.11. For each of the following rings R , give a careful description of the field of fractions K and show that the ring is a DVR by constructing an appropriate discrete valuation on K .

(a) $R = \{a/b \in \mathbb{Q} \mid a, b \in \mathbb{Z}, b \neq 0, \text{gcd}(b, p) = 1\}$, where p is a fixed prime number.

(b) $R = \mathbb{C}\{\{z\}\}$, the ring consisting of all power series in z with coefficient in \mathbb{C} that have a positive radius of convergence.

4.0.12. The plane curve $\mathbf{V}(x^3 - y^2) \subseteq \mathbb{C}^2$ has coordinate ring $R = \mathbb{C}[x, y]/\langle x^3 - y^2 \rangle$. As noted in Example 1.1.15, this is the coordinate ring of the affine toric variety given by the affine semigroup $S = \{0, 2, 3, \dots\}$. This semigroup is not saturated, which means that $R \simeq \mathbb{C}[S] = \mathbb{C}[t^2, t^3]$ is not normal by Theorem 1.3.5. It follows that R is not a DVR by

Theorem 4.0.4. Give a direct proof of this fact using only the definition of DVR. Hint: The field of fractions of $\mathbb{C}[t^2, t^3]$ is $\mathbb{C}(t)$. If $\mathbb{C}[t^2, t^3]$ comes from the discrete valuation ν , what is $\nu(t)$?

4.0.13. Let X be a normal variety. Use Proposition 4.0.16 to prove that there is an exact sequence

$$1 \longrightarrow \mathcal{O}_X(X)^* \longrightarrow \mathbb{C}(X)^* \longrightarrow \text{Div}(X) \longrightarrow \text{Cl}(X) \longrightarrow 0,$$

where the map $\mathbb{C}(X)^* \rightarrow \text{Div}(X)$ is $f \mapsto \text{div}(f)$ and $\text{Div}(X) \rightarrow \text{Cl}(X)$ is $D \mapsto [D]$. Similarly, prove that there is an exact sequence

$$1 \longrightarrow \mathcal{O}_X(X)^* \longrightarrow \mathbb{C}(X)^* \longrightarrow \text{CDiv}(X) \longrightarrow \text{Pic}(X) \longrightarrow 0.$$

4.0.14. Let $D = \sum_{\text{codim } \mathfrak{p}=1} a_{\mathfrak{p}} D_{\mathfrak{p}}$ be a Weil divisor on a normal affine variety $X = \text{Spec}(R)$. As usual, let K be the field of fractions of R . Here you give an algebraic description of $\Gamma(X, \mathcal{O}_X(D))$ in terms of the prime ideals \mathfrak{p} .

- (a) Let \mathfrak{p} be a codimension one prime of R , so that $R_{\mathfrak{p}}$ is a DVR. Hence the maximal ideal $\mathfrak{p}R_{\mathfrak{p}}$ is principal. Use this to define $\mathfrak{p}^a R_{\mathfrak{p}} \subseteq K$ for all $a \in \mathbb{Z}$.
- (b) Prove that

$$\Gamma(X, \mathcal{O}_X(D)) = \bigcap_{\text{codim } \mathfrak{p}=1} \mathfrak{p}^{-a_{\mathfrak{p}}} R_{\mathfrak{p}}.$$

- (c) Now assume that D is effective, i.e., $a_{\mathfrak{p}} \geq 0$ for all \mathfrak{p} . Prove that $\Gamma(X, \mathcal{O}_X(-D))$ is the ideal of R given by

$$\Gamma(X, \mathcal{O}_X(-D)) = \bigcap_{\text{codim } \mathfrak{p}=1} \mathfrak{p}^{a_{\mathfrak{p}}} R_{\mathfrak{p}}.$$

4.0.15. Let R be an integral domain with field of fractions K . A finitely generated R -submodule of K is called a *fractional ideal*. If R is normal and D is a Weil divisor on $X = \text{Spec}(R)$, explain why $\Gamma(X, \mathcal{O}_X(D)) \subseteq K$ is a fractional ideal.

§4.1. Weil Divisors on Toric Varieties

Let X_{Σ} be the toric variety of a fan Σ in $N_{\mathbb{R}}$ with $\dim N_{\mathbb{R}} = n$. Then X_{Σ} is normal of dimension n . We will use torus-invariant prime divisors and characters to give a lovely description of the class group of X_{Σ} .

The Divisor of a Character. The order of vanishing of a character along a torus-invariant prime divisor is determined by the polyhedral geometry of the fan.

By the Orbit-Cone Correspondence (Theorem 3.2.6), k -dimensional cones σ of Σ correspond to $(n-k)$ -dimensional T_N -orbits in X_{Σ} . As in Chapter 3, $\Sigma(1)$ is the set of 1-dimensional cones (i.e., the rays) of Σ . Thus $\rho \in \Sigma(1)$ gives the codimension one orbit $O(\rho)$ whose closure $\overline{O(\rho)}$ is a T_N -invariant prime divisor X_{Σ} . To emphasize that $\overline{O(\rho)}$ is a divisor we will denote it by D_{ρ} rather than $V(\rho)$. Then $D_{\rho} = \overline{O(\rho)}$ gives the DVR $\mathcal{O}_{X_{\Sigma}, D_{\rho}}$ with valuation

$$\nu_{\rho} = \nu_{D_{\rho}} : \mathbb{C}(X_{\Sigma})^* \rightarrow \mathbb{Z}.$$

Recall that the ray $\rho \in \Sigma(1)$ has a minimal generator $u_\rho \in \rho \cap N$. Also note that when $m \in M$, the character $\chi^m : T_N \rightarrow \mathbb{C}^*$ is a rational function in $\mathbb{C}(X_\Sigma)^*$ since T_N is Zariski open in X_Σ .

Proposition 4.1.1. *Let X_Σ be the toric variety of a fan Σ . If the ray $\rho \in \Sigma(1)$ has minimal generator u_ρ and χ^m is character corresponding to $m \in M$, then*

$$\nu_\rho(\chi^m) = \langle m, u_\rho \rangle.$$

Proof. Since $u_\rho \in N$ is primitive, we can extend u_ρ to a basis $e_1 = u_\rho, e_2, \dots, e_n$ of N , then we can assume $N = \mathbb{Z}^n$ and $\rho = \text{Cone}(e_1) \subseteq \mathbb{R}^n$. By Example 1.2.20, the corresponding affine toric variety is

$$U_\rho = \text{Spec}(\mathbb{C}[x_1, x_2^{\pm 1}, \dots, x_n^{\pm 1}]) = \mathbb{C} \times (\mathbb{C}^*)^{n-1}$$

and $D_\rho \cap U_\rho$ is defined by $x_1 = 0$. It follows easily that the DVR is

$$\mathcal{O}_{X_\Sigma, D_\rho} = \mathcal{O}_{U_\rho, U_\rho \cap D_\rho} = \mathbb{C}[x_1, \dots, x_n]_{\langle x_1 \rangle}.$$

Similar to Example 4.0.6, $f \in \mathbb{C}(x_1, \dots, x_n)^*$ has valuation $\nu_\rho(f) = n \in \mathbb{Z}$ when

$$f = x_1^n \frac{g}{h}, \quad g, h \in \mathbb{C}[x_1, \dots, x_n] \setminus \langle x_1 \rangle.$$

To relate this to $\nu_\rho(\chi^m)$, note that x_1, \dots, x_n are the characters of the dual basis of $e_1 = u_\rho, e_2, \dots, e_n \in N$. It follows that given any $m \in M$, we have

$$\chi^m = x_1^{\langle m, e_1 \rangle} x_2^{\langle m, e_2 \rangle} \dots x_n^{\langle m, e_n \rangle} = x_1^{\langle m, u_\rho \rangle} x_2^{\langle m, e_2 \rangle} \dots x_n^{\langle m, e_n \rangle}.$$

Comparing this to the previous equation implies that $\nu_\rho(\chi^m) = \langle m, u_\rho \rangle$. □

We next compute the divisor of a character. As above, a ray $\rho \in \Sigma(1)$ gives:

- A minimal generator $u_\rho \in \rho \cap N$.
- A prime T_N -invariant divisor $D_\rho = \overline{O(\rho)}$ on X_Σ .

We will use this notation for the remainder of the chapter.

Proposition 4.1.2. *For $m \in M$, the character χ^m is a rational function on X_Σ , and its divisor is given by*

$$\text{div}(\chi^m) = \sum_{\rho \in \Sigma(1)} \langle m, u_\rho \rangle D_\rho.$$

Proof. The Orbit-Cone Correspondence (Theorem 3.2.6) implies that the D_ρ are the irreducible components of $X \setminus T_N$. Since χ^m is defined and nonzero on T_N , it follows that χ^m is supported on $\bigcup_{\rho \in \Sigma(1)} D_\rho$. Hence

$$\text{div}(\chi^m) = \sum_{\rho \in \Sigma(1)} \nu_{D_\rho}(\chi^m) D_\rho.$$

Then we are done since $\nu_{D_\rho}(\chi^m) = \langle m, u_\rho \rangle$ by Proposition 4.1.1. □

Computing the Class Group. Divisors of the form $\sum_{\rho \in \Sigma(1)} a_\rho D_\rho$ are precisely the divisors invariant under the torus action on X_Σ (Exercise 4.1.1). Thus

$$\operatorname{Div}_{T_N}(X_\Sigma) = \bigoplus_{\rho \in \Sigma(1)} \mathbb{Z}D_\rho \subseteq \operatorname{Div}(X_\Sigma)$$

is the group of T_N -invariant Weil divisors on X_Σ . Here is the main result of this section.

Theorem 4.1.3. *We have the exact sequence*

$$M \longrightarrow \operatorname{Div}_{T_N}(X_\Sigma) \longrightarrow \operatorname{Cl}(X_\Sigma) \longrightarrow 0,$$

where the first map is $m \mapsto \operatorname{div}(\chi^m)$ and the second sends a T_N -invariant divisor to its divisor class in $\operatorname{Cl}(X_\Sigma)$. Furthermore, we have a short exact sequence

$$0 \longrightarrow M \longrightarrow \operatorname{Div}_{T_N}(X_\Sigma) \longrightarrow \operatorname{Cl}(X_\Sigma) \longrightarrow 0$$

if and only if $\{u_\rho \mid \rho \in \Sigma(1)\}$ spans $N_{\mathbb{R}}$, i.e., X_Σ has no torus factors.

Proof. Since the D_ρ are the irreducible components of $X_\Sigma \setminus T_N$, Theorem 4.0.20 implies that we have an exact sequence

$$\operatorname{Div}_{T_N}(X_\Sigma) \longrightarrow \operatorname{Cl}(X_\Sigma) \longrightarrow \operatorname{Cl}(T_N) \longrightarrow 0.$$

Since $\mathbb{C}[x_1, \dots, x_n]$ is a UFD, the same is true for $\mathbb{C}[x_1^{\pm 1}, \dots, x_n^{\pm 1}]$. This is the coordinate ring of the torus $(\mathbb{C}^*)^n$, which is isomorphic to the coordinate ring $\mathbb{C}[M]$ of the torus T_N . Hence $\mathbb{C}[M]$ is also a UFD, which implies $\operatorname{Cl}(T_N) = 0$ by Theorem 4.0.18. We conclude that $\operatorname{Div}_{T_N}(X_\Sigma) \rightarrow \operatorname{Cl}(X_\Sigma)$ is surjective.

The composition $M \rightarrow \operatorname{Div}_{T_N}(X_\Sigma) \rightarrow \operatorname{Cl}(X_\Sigma)$ is obviously zero since the first map is $m \mapsto \operatorname{div}(\chi^m)$. Now suppose that $D \in \operatorname{Div}_{T_N}(X_\Sigma)$ maps to 0 in $\operatorname{Cl}(X_\Sigma)$. Then $D = \operatorname{div}(f)$ for some $f \in \mathbb{C}(X_\Sigma)^*$. Since the support of D misses T_N , this implies that $\operatorname{div}(f)$ restricts to 0 on T_N . When regarded as an element of $\mathbb{C}(T_N)^*$, f has zero divisor on T_N , so that $f \in \mathbb{C}[M]^*$ by Proposition 4.0.16. Thus $f = c\chi^m$ for some $c \in \mathbb{C}^*$ and $m \in M$ (Exercise 3.3.4). It follows that on X_Σ ,

$$D = \operatorname{div}(f) = \operatorname{div}(c\chi^m) = \operatorname{div}(\chi^m),$$

which proves exactness at $\operatorname{Div}_{T_N}(X_\Sigma)$.

Finally, suppose that $m \in M$ with $\operatorname{div}(\chi^m) = \sum_{\rho \in \Sigma(1)} \langle m, u_\rho \rangle D_\rho$ is the zero divisor. Then $\langle m, u_\rho \rangle = 0$ for all $\rho \in \Sigma(1)$, which forces $m = 0$ when the u_ρ span $N_{\mathbb{R}}$. This gives the desired exact sequence. Conversely, if the sequence is exact, then one easily sees that the u_ρ span $N_{\mathbb{R}}$, which by Corollary 3.3.10 is equivalent to X_Σ having no torus factors. \square

In particular, we see that $\operatorname{Cl}(X_\Sigma)$ is a finitely generated abelian group.

Examples. It is easy to compute examples of class groups of toric varieties. In practice, one usually picks a basis e_1, \dots, e_n of M , so that $M \simeq \mathbb{Z}^n$ and (via the dual basis) $N \simeq \mathbb{Z}^n$. Then the pairing $\langle m, u \rangle$ becomes dot product. We list the rays of Σ as ρ_1, \dots, ρ_r with corresponding ray generators $u_1, \dots, u_r \in \mathbb{Z}^n$. We will think of u_i as the column vector $(\langle e_1, u_i \rangle, \dots, \langle e_n, u_i \rangle)^T$, where the superscript denotes transpose.

With this setup, the map $M \rightarrow \text{Div}_{T_N}(X_\Sigma)$ in Theorem 4.1.3 is the map

$$A : \mathbb{Z}^n \longrightarrow \mathbb{Z}^r$$

represented by the matrix whose columns are the ray generators. In other words, $A = (u_1, \dots, u_r)^T$. By Theorem 4.1.3, the class group of X_Σ is the cokernel of this map, which is easily computed from the Smith normal form of A .

When we want to think in terms of divisors, we let D_i be the T_N -invariant prime divisor corresponding to $\rho_i \in \Sigma(1)$.

Example 4.1.4. The affine toric surface described in Example 1.2.21 comes from the cone $\sigma = \text{Cone}(de_1 - e_2, e_2)$. For $d = 3$, σ is shown in Figure 1. The resulting

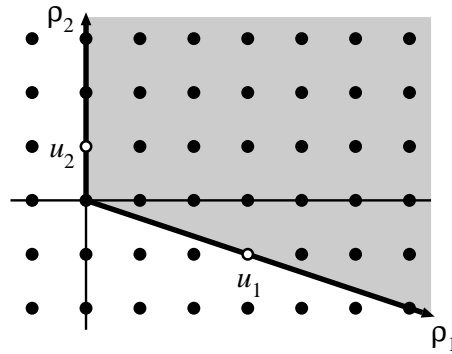

Figure 1. The cone σ^\vee when $d = 3$

toric variety U_σ is the rational normal cone \widehat{C}_d . Using the ray generators $u_1 = de_1 - e_2 = (d, -1)$ and $u_2 = e_2 = (0, 1)$, we get the map $\mathbb{Z}^2 \rightarrow \mathbb{Z}^2$ given by the matrix

$$A = \begin{pmatrix} d & 0 \\ -1 & 1 \end{pmatrix}.$$

This makes it easy to compute that

$$\text{Cl}(\widehat{C}_d) \simeq \mathbb{Z}/d\mathbb{Z}.$$

We can also see this in terms of divisors as follows. The class group $\text{Cl}(\widehat{C}_d)$ is generated by the classes of the divisors D_1, D_2 corresponding to ρ_1, ρ_2 , subject to

the relations coming from the exact sequence of Theorem 4.1.3:

$$0 \sim \operatorname{div}(\chi^{e_1}) = \langle e_1, u_1 \rangle D_1 + \langle e_1, u_2 \rangle D_2 = dD_1$$

$$0 \sim \operatorname{div}(\chi^{e_2}) = \langle e_2, u_1 \rangle D_1 + \langle e_2, u_2 \rangle D_2 = -D_1 + D_2.$$

Thus $\operatorname{Cl}(\widehat{C}_d)$ is generated by $[D_1]$ with $d[D_1] = 0$, giving $\operatorname{Cl}(\widehat{C}_d) \simeq \mathbb{Z}/d\mathbb{Z}$. \diamond

Example 4.1.5. In Example 3.1.4, we saw that the blowup of \mathbb{C}^2 at the origin is the toric variety $\operatorname{Bl}_0(\mathbb{C}^2)$ given by the fan Σ shown in Figure 2.

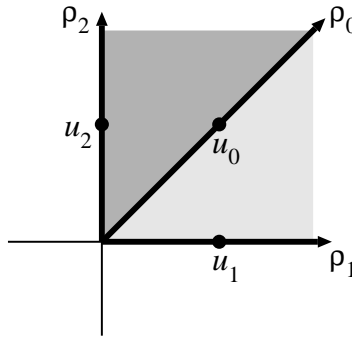

Figure 2. The fan for the blowup of \mathbb{C}^2 at the origin

The ray generators are $u_1 = e_1, u_2 = e_2, u_0 = e_1 + e_2$ corresponding to divisors D_1, D_2, D_0 . By Theorem 4.1.3, the class group is generated by the classes of the D_i subject to the relations

$$0 \sim \operatorname{div}(\chi^{e_1}) = D_1 + D_0$$

$$0 \sim \operatorname{div}(\chi^{e_2}) = D_2 + D_0.$$

Thus $\operatorname{Cl}(\operatorname{Bl}_0(\mathbb{C}^2)) \simeq \mathbb{Z}$ with generator $[D_1] = [D_2] = -[D_0]$. This calculation can also be done using matrices as in the previous example. \diamond

Example 4.1.6. The fan of \mathbb{P}^n has ray generators given by $u_0 = -e_1 - \cdots - e_n$ and $u_1 = e_1, \dots, u_n = e_n$. Thus the map $M \rightarrow \operatorname{Div}_{T_N}(\mathbb{P}^n)$ can be written as

$$\begin{aligned} \mathbb{Z}^n &\longrightarrow \mathbb{Z}^{n+1} \\ (a_1, \dots, a_n) &\longmapsto (-a_1 - \cdots - a_n, a_1, \dots, a_n). \end{aligned}$$

Using the map

$$\begin{aligned} \mathbb{Z}^{n+1} &\longrightarrow \mathbb{Z} \\ (b_0, \dots, b_n) &\longmapsto b_0 + \cdots + b_n, \end{aligned}$$

one gets the exact sequence

$$0 \longrightarrow \mathbb{Z}^n \longrightarrow \mathbb{Z}^{n+1} \longrightarrow \mathbb{Z} \longrightarrow 0,$$

which proves that $\text{Cl}(\mathbb{P}^n) \simeq \mathbb{Z}$, generalizing Example 4.0.21. It is easy to redo this calculation using divisors as in the previous example. \diamond

Example 4.1.7. The class group $\text{Cl}(\mathbb{P}^n \times \mathbb{P}^m)$ is isomorphic to \mathbb{Z}^2 . More generally,

$$\text{Cl}(X_{\Sigma_1} \times X_{\Sigma_2}) \simeq \text{Cl}(X_{\Sigma_1}) \oplus \text{Cl}(X_{\Sigma_2}).$$

You will prove this in Exercise 4.1.2. \diamond

Example 4.1.8. The Hirzebruch surfaces \mathcal{H}_r are described in Example 3.1.16. The fan for \mathcal{H}_r appears in Figure 3, along with the ray generators $u_1 = -e_1 + re_2$, $u_2 = e_2$, $u_3 = e_1$, $u_4 = -e_2$.

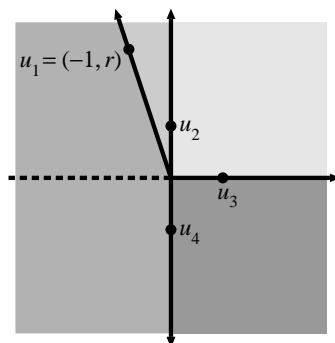

Figure 3. A fan Σ_r with $X_{\Sigma_r} \simeq \mathcal{H}_r$

The class group is generated by the classes of D_1, D_2, D_3, D_4 , with relations

$$0 \sim \text{div}(\chi^{e_1}) = -D_1 + D_3$$

$$0 \sim \text{div}(\chi^{e_2}) = rD_1 + D_2 - D_4.$$

It follows that $\text{Cl}(\mathcal{H}_r)$ is the free abelian group generated by $[D_1]$ and $[D_2]$. Thus

$$\text{Cl}(\mathcal{H}_r) \simeq \mathbb{Z}^2.$$

In particular, $r = 0$ gives $\text{Cl}(\mathcal{H}_0) = \text{Cl}(\mathbb{P}^1 \times \mathbb{P}^1) \simeq \mathbb{Z}^2$, which is a special case of Example 4.1.7. \diamond

Exercises for §4.1.

4.1.1. This exercise will determine which divisors are invariant under the T_N -action on X_Σ . Given $t \in T_N$ and $p \in X_\Sigma$, the T_N -action gives $t \cdot p \in X_\Sigma$. If D is a prime divisor, the T_N -action gives the prime divisor $t \cdot D$. For an arbitrary Weil divisor $D = \sum_i a_i D_i$, $t \cdot D = \sum_i a_i (t \cdot D_i)$. Then D is T_N -invariant if $t \cdot D = D$ for all $t \in T_N$.

- (a) Show that $\sum_{\rho \in \Sigma(1)} a_\rho D_\rho$ is T_N -invariant.
- (b) Conversely, show that any T_N -invariant Weil divisor can be written as in part (a). Hint: Consider $\text{Supp}(D)$ and use the Orbit-Cone Correspondence.

4.1.2. Given fans Σ_1 in $(N_1)_{\mathbb{R}}$ and Σ_2 in $(N_2)_{\mathbb{R}}$, we get the product fan

$$\Sigma_1 \times \Sigma_2 = \{\sigma_1 \times \sigma_2 \mid \sigma_i \in \Sigma_i\},$$

which by Proposition 3.1.14 is the fan of the toric variety $X_{\Sigma_1} \times X_{\Sigma_2}$. Prove that

$$\text{Cl}(X_{\Sigma_1} \times X_{\Sigma_2}) \simeq \text{Cl}(X_{\Sigma_1}) \oplus \text{Cl}(X_{\Sigma_2}).$$

Hint: The product fan has rays $\rho_1 \times \{0\}$ and $\{0\} \times \rho_2$ for $\rho_1 \in \Sigma_1(1)$ and $\rho_2 \in \Sigma_2(1)$.

4.1.3. Redo the divisor class group calculation given in Example 4.1.5 using matrices, and redo the calculation given in Example 4.1.6 using divisors.

4.1.4. The blowup of \mathbb{C}^n at the origin is the toric variety $\text{Bl}_0(\mathbb{C}^n)$ of the fan Σ described in Example 3.1.15. Prove that $\text{Cl}(\text{Bl}_0(\mathbb{C}^n)) \simeq \mathbb{Z}$.

4.1.5. The weighted projective space $\mathbb{P}(q_0, \dots, q_n)$, $\gcd(q_0, \dots, q_n) = 1$, is built from a fan in $N = \mathbb{Z}^{n+1}/\mathbb{Z}(q_0, \dots, q_n)$. The dual lattice is

$$M = \{(a_0, \dots, a_n) \in \mathbb{Z}^{n+1} \mid a_0 q_0 + \dots + a_n q_n = 0\}.$$

Let $u_0, \dots, u_n \in N$ denote the images of the standard basis $e_0, \dots, e_n \in \mathbb{Z}^{n+1}$. The u_i are the ray generators of the fan giving $\mathbb{P}(q_0, \dots, q_n)$. Define maps

$$\begin{aligned} M &\longrightarrow \mathbb{Z}^{n+1} : m \longmapsto (\langle m, u_0 \rangle, \dots, \langle m, u_n \rangle) \\ \mathbb{Z}^{n+1} &\longrightarrow \mathbb{Z} : (a_0, \dots, a_n) \longmapsto a_0 q_0 + \dots + a_n q_n. \end{aligned}$$

Show that these maps give an exact sequence

$$0 \longrightarrow M \longrightarrow \mathbb{Z}^{n+1} \longrightarrow \mathbb{Z} \longrightarrow 0$$

and conclude that $\text{Cl}(\mathbb{P}(q_0, \dots, q_n)) \simeq \mathbb{Z}$.

§4.2. Cartier Divisors on Toric Varieties

Let X_{Σ} be the toric variety of a fan Σ . We will use the same notation as in §4.1, where each $\rho \in \Sigma(1)$ gives a minimal ray generator u_{ρ} and a T_N -invariant prime divisor $D_{\rho} \subseteq X_{\Sigma}$. In what follows, we write \sum_{ρ} for a summation over the rays $\rho \in \Sigma(1)$ when there is no danger of confusion.

Computing the Picard Group. A Cartier divisor D on X_{Σ} is also a Weil divisor and hence

$$D \sim \sum_{\rho} a_{\rho} D_{\rho}, \quad a_{\rho} \in \mathbb{Z},$$

by Theorem 4.1.3. Then $\sum_{\rho} a_{\rho} D_{\rho}$ is Cartier since D is (Exercise 4.0.5). Let

$$\text{CDiv}_{T_N}(X_{\Sigma}) \subseteq \text{Div}_{T_N}(X_{\Sigma})$$

denote the subgroup of $\text{Div}_{T_N}(X_{\Sigma})$ consisting of T_N -invariant Cartier divisors. Since $\text{div}(\chi^m) \in \text{CDiv}_{T_N}(X_{\Sigma})$ for all $m \in M$, we get the following immediate corollary of Theorem 4.1.3.

Theorem 4.2.1. *We have an exact sequence*

$$M \longrightarrow \text{CDiv}_{T_N}(X_\Sigma) \longrightarrow \text{Pic}(X_\Sigma) \longrightarrow 0,$$

where the first map is defined above and the second sends a T_N -invariant divisor to its divisor class in $\text{Pic}(X_\Sigma)$. Furthermore, we have a short exact sequence

$$0 \longrightarrow M \longrightarrow \text{CDiv}_{T_N}(X_\Sigma) \longrightarrow \text{Pic}(X_\Sigma) \longrightarrow 0$$

if and only if $\{u_\rho \mid \rho \in \Sigma(1)\}$ spans $N_{\mathbb{R}}$. □

Our next task is to determine the structure of $\text{CDiv}_{T_N}(X_\Sigma)$. In other words, which T_N -invariant divisors are Cartier? We begin with the affine case.

Proposition 4.2.2. *Let $\sigma \subseteq N_{\mathbb{R}}$ be a strongly convex polyhedral cone. Then:*

- (a) *Every T_N -invariant Cartier divisor on U_σ is the divisor of a character.*
- (b) $\text{Pic}(U_\sigma) = 0$.

Proof. Let $R = \mathbb{C}[\sigma^\vee \cap M]$. First suppose that $D = \sum_\rho a_\rho D_\rho$ is an effective T_N -invariant Cartier divisor. Using Proposition 4.0.16 as in the proof of Proposition 4.0.28, we see that

$$\Gamma(U_\sigma, \mathcal{O}_{U_\sigma}(-D)) = \{f \in K \mid f = 0, \text{ or } f \neq 0 \text{ and } \text{div}(f) \geq D\}$$

is an ideal $I \subseteq R$. Furthermore, I is T_N -invariant since D is. Hence

$$(4.2.1) \quad I = \bigoplus_{\chi^m \in I} \mathbb{C} \cdot \chi^m = \bigoplus_{\text{div}(\chi^m) \geq D} \mathbb{C} \cdot \chi^m$$

by Lemma 1.1.16.

Under the Orbit-Cone Correspondence (Theorem 3.2.6), a ray $\rho \in \sigma(1)$ gives an inclusion of T_N -orbits $O(\sigma) \subseteq O(\rho) \subseteq \overline{O(\rho)} = D_\rho$. Thus

$$O(\sigma) \subseteq \bigcap_{\rho} D_\rho.$$

Now fix a point $p \in O(\sigma)$. Since D is Cartier, it is locally principal, and in particular is principal in a neighborhood U of p . Shrinking U if necessary, we may assume that $U = (U_\sigma)_h = \text{Spec}(R_h)$, where $h \in R$ satisfies $h(p) \neq 0$.

Thus $D|_U = \text{div}(f)|_U$ for some $f \in \mathbb{C}(U_\sigma)^*$. Since D is effective, $f \in R_h$ by Proposition 4.0.16, and since h is invertible on U , we may assume $f \in R$. Then

$$\text{div}(f) = \sum_{\rho} \nu_{D_\rho}(f) D_\rho + \sum_{E \neq D_\rho} \nu_E(f) E \geq \sum_{\rho} \nu_{D_\rho}(f) D_\rho = D.$$

Here, $\sum_{E \neq D_\rho}$ denotes the sum over all prime divisors different from the D_ρ . The first equality is the definition of $\text{div}(f)$, the second inequality follows since $f \in R$, and the final equality follows from $D|_U = \text{div}(f)|_U$ since $p \in U \cap D_\rho$ for all $\rho \in \sigma(1)$. This shows that $\text{div}(f) \geq D$, so that $f \in I$.

Using (4.2.1), we can write $f = \sum_i a_i \chi^{m_i}$ with $a_i \in \mathbb{C}^*$ and $\operatorname{div}(\chi^{m_i}) \geq D$. Restricting to U , this becomes $\operatorname{div}(\chi^{m_i})|_U \geq \operatorname{div}(f)|_U$, which implies that χ^{m_i}/f is a morphism on U by Proposition 4.0.16. Then

$$1 = \frac{\sum_i a_i \chi^{m_i}}{f} = \sum_i a_i \frac{\chi^{m_i}}{f}$$

and $p \in U$ imply that $(\chi^{m_i}/f)(p) \neq 0$ for some i . Hence χ^{m_i}/f is nonvanishing in some open set V with $p \in V \subseteq U$. It follows that

$$\operatorname{div}(\chi^{m_i})|_V = \operatorname{div}(f)|_V = D|_V.$$

Since $\operatorname{div}(\chi^{m_i})$ and D have support contained in $\bigcup_\rho D_\rho$ and every D_ρ meets V (this follows from $p \in V \cap D_\rho$), we have $\operatorname{div}(\chi^{m_i}) = D$.

To finish the proof of (a), let D be an arbitrary T_N -invariant Cartier divisor on U_σ . Since $\dim \sigma^\vee = \dim M_{\mathbb{R}}$ (σ is strongly convex), we can find $m \in \sigma^\vee \cap M$ such that $\langle m, u_\rho \rangle > 0$ for all $\rho \in \sigma(1)$. Thus $\operatorname{div}(\chi^m)$ is a positive linear combination of the D_ρ , which implies that $D' = D + \operatorname{div}(\chi^{km}) \geq 0$ for $k \in \mathbb{N}$ sufficiently large. The above argument implies that D' is the divisor of a character, so that the same is true for D . This completes the proof of part (a), and part (b) follows immediately using Theorem 4.2.1. \square

Example 4.2.3. The rational normal cone \widehat{C}_d is the affine toric variety of the cone $\sigma = \operatorname{Cone}(de_1 - e_2, e_2) \subseteq \mathbb{R}^2$. We saw in Example 4.1.4 that $\operatorname{Cl}(U_\sigma) \simeq \mathbb{Z}/d\mathbb{Z}$. The edges ρ_1, ρ_2 of σ give prime divisors D_1, D_2 on \widehat{C}_d , and the computations of Example 4.1.4 show that $[D_1] = [D_2]$ generates $\operatorname{Cl}(U_\sigma)$. Since $\operatorname{Pic}(U_\sigma) = 0$ by Proposition 4.2.2, it follows that the Weil divisors D_1, D_2 are not Cartier if $d > 1$.

Next consider the fan Σ_0 consisting of the cones $\rho_1, \rho_2, \{0\}$. This is a subfan of the fan Σ giving \widehat{C}_d , and the corresponding toric variety is $X_{\Sigma_0} \simeq \widehat{C}_d \setminus \{\gamma_\sigma\}$, where γ_σ is the distinguished point that is the unique fixed point of the T_N -action on \widehat{C}_d . The variety X_{Σ_0} is smooth since every cone in Σ_0 is smooth (Theorem 3.1.19). Since Σ_0 and Σ have the same 1-dimensional cones, they have the same class group by Theorem 4.1.3. Thus

$$\operatorname{Pic}(X_{\Sigma_0}) = \operatorname{Cl}(X_{\Sigma_0}) = \operatorname{Cl}(X_\Sigma) = \operatorname{Cl}(\widehat{C}_d) \simeq \mathbb{Z}/d\mathbb{Z}.$$

It follows that X_{Σ_0} is a smooth toric surface whose Picard group has torsion. \diamond

Example 4.2.4. One of our favorite examples is $X = \mathbf{V}(xy - zw) \subseteq \mathbb{C}^4$, which is the toric variety of the cone $\sigma = \operatorname{Cone}(e_1, e_2, e_1 + e_3, e_2 + e_3) \subseteq \mathbb{R}^3$. The ray generators are

$$u_1 = e_1, u_2 = e_2, u_3 = e_1 + e_3, u_4 = e_2 + e_3.$$

Note that $u_1 + u_4 = u_2 + u_3$. Let $D_i \subseteq X$ be the divisor corresponding to u_i . In Exercise 4.2.1 you will verify that

$$a_1 D_1 + a_2 D_2 + a_3 D_3 + a_4 D_4 \text{ is Cartier} \iff a_1 + a_4 = a_2 + a_3$$

and that $\text{Cl}(X) \simeq \mathbb{Z}$. Since $\text{Pic}(X) = 0$, we see that the D_i are not Cartier, and in fact no positive multiple of D_i is Cartier. \diamond

Example 4.2.3 shows that the Picard group of a normal toric variety can have torsion. However, if we assume that Σ has a cone of maximal dimension, then the torsion goes away. Here is the precise result.

Proposition 4.2.5. *Let X_Σ be the toric variety of a fan Σ in $N_{\mathbb{R}} \simeq \mathbb{R}^n$. If Σ contains a cone of dimension n , then $\text{Pic}(X_\Sigma)$ is a free abelian group.*

Proof. By the exact sequence in Theorem 4.2.1, it suffices to show that if D is a T_N -invariant Cartier divisor and kD is the divisor of a character for some $k > 0$, then the same is true for D . To prove this, write $D = \sum_{\rho} a_{\rho} D_{\rho}$ and assume that $kD = \text{div}(\chi^m)$, $m \in M$.

Let σ have dimension n . Since D is Cartier, its restriction to U_{σ} is also Cartier. Using the Orbit-Cone Correspondence, we have

$$D|_{U_{\sigma}} = \sum_{\rho \in \sigma(1)} a_{\rho} D_{\rho}.$$

This is principal on U_{σ} by Proposition 4.2.2, so that there is $m' \in M$ such that $D|_{U_{\sigma}} = \text{div}(\chi^{m'})|_{U_{\sigma}}$. This implies that

$$a_{\rho} = \langle m', u_{\rho} \rangle \quad \text{for all } \rho \in \sigma(1).$$

On the other hand, $kD = \text{div}(\chi^m)$ implies that

$$ka_{\rho} = \langle m, u_{\rho} \rangle \quad \text{for all } \rho \in \Sigma(1).$$

Together, these equations imply

$$\langle km', u_{\rho} \rangle = ka_{\rho} = \langle m, u_{\rho} \rangle \quad \text{for all } \rho \in \sigma(1).$$

The u_{ρ} span $N_{\mathbb{R}}$ since $\dim \sigma = n$. Then the above equation forces $km' = m$, and $D = \text{div}(\chi^{m'})$ follows easily. \square

This proposition does not contradict the torsion Picard group in Example 4.2.3 since the fan Σ_0 in that example has no maximal cone.

Comparing Weil and Cartier Divisors. Here is an application of Proposition 4.2.2.

Proposition 4.2.6. *Let X_Σ be the toric variety of the fan Σ . Then the following are equivalent:*

- (a) *Every Weil divisor on X_Σ is Cartier.*
- (b) $\text{Pic}(X_\Sigma) = \text{Cl}(X_\Sigma)$.
- (c) X_Σ is smooth.

Proof. (a) \Leftrightarrow (b) is obvious, and (c) \Rightarrow (a) follows from Theorem 4.0.22. For the converse, suppose that every Weil divisor on X_Σ is Cartier and let $U_\sigma \subseteq X_\Sigma$ be the affine open subset corresponding to $\sigma \in \Sigma$. Since $\text{Cl}(X_\Sigma) \rightarrow \text{Cl}(U_\sigma)$ is onto by Theorem 4.0.20, it follows that every Weil divisor on U_σ is Cartier. Using $\text{Pic}(U_\sigma) = 0$ from Proposition 4.2.2 and the exact sequence from Theorem 4.1.3, we conclude that $m \mapsto \text{div}(\chi^m)$ induces a surjective map

$$M \longrightarrow \text{Div}_{T_N}(U_\sigma) = \bigoplus_{\rho \in \sigma(1)} \mathbb{Z}D_\rho.$$

Writing $\sigma(1) = \{\rho_1, \dots, \rho_s\}$, this map becomes

$$(4.2.2) \quad \begin{aligned} M &\longrightarrow \mathbb{Z}^s \\ m &\longmapsto (\langle m, u_{\rho_1} \rangle, \dots, \langle m, u_{\rho_s} \rangle). \end{aligned}$$

Now define $\Phi : \mathbb{Z}^s \rightarrow N$ by $\Phi(a_1, \dots, a_s) = \sum_{i=1}^s a_i u_{\rho_i}$. The dual map

$$\Phi^* : M = \text{Hom}_{\mathbb{Z}}(N, \mathbb{Z}) \longrightarrow \text{Hom}_{\mathbb{Z}}(\mathbb{Z}^s, \mathbb{Z}) = \mathbb{Z}^s$$

is easily seen to be (4.2.2). In Exercise 4.2.2 you will show that

$$(4.2.3) \quad \begin{aligned} \Phi^* \text{ is surjective} &\iff \Phi \text{ is injective and } N/\Phi(\mathbb{Z}^s) \text{ is torsion-free.} \\ &\iff u_{\rho_1}, \dots, u_{\rho_s} \text{ can be extended to a basis of } N. \end{aligned}$$

The first part of the proof shows that Φ^* is surjective. Then (4.2.3) implies that the u_ρ for $\rho \in \sigma(1)$ can be extended to a basis of N , which implies that σ is smooth. Then X_Σ is smooth by Theorem 3.1.19. \square

Proposition 4.2.6 has a simplicial analog. Recall that X_Σ is simplicial when every $\sigma \in \Sigma$ is simplicial, meaning that the minimal generators of σ are linearly independent over \mathbb{R} . You will prove the following result in Exercise 4.2.2.

Proposition 4.2.7. *Let X_Σ be the toric variety of the fan Σ . Then the following are equivalent:*

- (a) *Every Weil divisor on X_Σ has a positive integer multiple that is Cartier.*
- (b) *$\text{Pic}(X_\Sigma)$ has finite index in $\text{Cl}(X_\Sigma)$.*
- (c) *X_Σ is simplicial.* \square

In the literature, a Weil divisor is called \mathbb{Q} -Cartier if some positive integer multiple is Cartier. Thus Proposition 4.2.7 characterizes those normal toric varieties for which all Weil divisors are \mathbb{Q} -Cartier.

Describing Cartier Divisors. We can use Proposition 4.2.2 to characterize T_N -invariant Cartier divisors as follows. Let $\Sigma_{\max} \subseteq \Sigma$ be the set of maximal cones of Σ , meaning cones in Σ that are not proper subsets of another cone in Σ .

Theorem 4.2.8. *Let X_Σ be the toric variety of the fan Σ and let $D = \sum_\rho a_\rho D_\rho$. Then the following are equivalent:*

- (a) D is Cartier.
- (b) D is principal on the affine open subset U_σ for all $\sigma \in \Sigma$.
- (c) For each $\sigma \in \Sigma$, there is $m_\sigma \in M$ with $\langle m_\sigma, u_\rho \rangle = -a_\rho$ for all $\rho \in \sigma(1)$.
- (d) For each $\sigma \in \Sigma_{\max}$, there is $m_\sigma \in M$ with $\langle m_\sigma, u_\rho \rangle = -a_\rho$ for all $\rho \in \sigma(1)$.

Furthermore, if D is Cartier and $\{m_\sigma\}_{\sigma \in \Sigma}$ is as in part (c), then:

- (1) m_σ is unique modulo $M(\sigma) = \sigma^\perp \cap M$.
- (2) If τ is a face of σ , then $m_\sigma \equiv m_\tau \pmod{M(\tau)}$.

Proof. Since $D|_{U_\sigma} = \sum_{\rho \in \sigma(1)} a_\rho D_\rho$, the equivalences (a) \Leftrightarrow (b) \Leftrightarrow (c) follow immediately from Proposition 4.2.2. The implication (c) \Rightarrow (d) is clear, and (d) \Rightarrow (c) follows because every cone in Σ is a face of some $\sigma \in \Sigma_{\max}$ and if $m_\sigma \in \Sigma_{\max}$ works for σ , it also works for all faces of σ .

For (1), suppose that $m_\sigma \in M$ satisfies $\langle m_\sigma, u_\rho \rangle = -a_\rho$ for all $\rho \in \sigma(1)$. Then, given $m'_\sigma \in M$, we have

$$\begin{aligned} \langle m'_\sigma, u_\rho \rangle = -a_\rho \text{ for all } \rho \in \sigma(1) &\iff \langle m'_\sigma - m_\sigma, u_\rho \rangle = 0 \text{ for all } \rho \in \sigma(1) \\ &\iff \langle m'_\sigma - m_\sigma, u \rangle = 0 \text{ for all } u \in \sigma \\ &\iff m'_\sigma - m_\sigma \in \sigma^\perp \cap M = M(\sigma). \end{aligned}$$

It follows that m_σ is unique modulo $M(\sigma)$. Since m_σ works for any face τ of σ , uniqueness implies that $m_\sigma \equiv m_\tau \pmod{M(\tau)}$, and (2) follows. \square

The m_σ of part (c) of the theorem satisfy $D|_{U_\sigma} = \text{div}(\chi^{-m_\sigma})|_{U_\sigma}$ for all $\sigma \in \Sigma$. Thus $\{(U_\sigma, \chi^{-m_\sigma})\}_{\sigma \in \Sigma}$ is local data for D in the sense of Definition 4.0.12. We call $\{m_\sigma\}_{\sigma \in \Sigma}$ the *Cartier data* of D .

The minus signs in parts (c) and (d) of the theorem are related to the minus signs in the facet presentation of a lattice polytope given in (2.2.2), namely

$$P = \{m \in M_{\mathbb{R}} \mid \langle m, u_F \rangle \geq -a_F \text{ for all facets } F \text{ of } P\}.$$

We will say more about this below. The minus signs are also related to *support functions*, to be discussed later in the section.

When Σ is a complete fan in $N_{\mathbb{R}} \simeq \mathbb{R}^n$, part (d) of Theorem 4.2.8 can be recast as follows. Let $\Sigma(n) = \{\sigma \in \Sigma \mid \dim \sigma = n\}$. In Exercise 4.2.3 you will show that a Weil divisor $D = \sum_\rho a_\rho D_\rho$ is Cartier if and only if:

- (d)' For each $\sigma \in \Sigma(n)$, there is $m_\sigma \in M$ with $\langle m_\sigma, u_\rho \rangle = -a_\rho$ for all $\rho \in \sigma(1)$.

Part (1) of Theorem 4.2.8 shows that these m_σ 's are uniquely determined.

In general, each m_σ in Theorem 4.2.8 is only unique modulo $M(\sigma)$. Hence we can regard m_σ as a uniquely determined element of $M/M(\sigma)$. Furthermore, if τ is a face of σ , then the canonical map $M/M(\sigma) \rightarrow M/M(\tau)$ sends m_σ to m_τ .

There are two ways to turn these observations into a complete description of $\text{CDiv}_{T_N}(X_\Sigma)$. For the first, write

$$\Sigma_{\max} = \{\sigma_1, \dots, \sigma_r\}$$

and consider the map

$$\begin{aligned} \bigoplus_i M/M(\sigma_i) &\longrightarrow \bigoplus_{i<j} M/M(\sigma_i \cap \sigma_j) \\ (m_i)_i &\longmapsto (m_i - m_j)_{i<j}. \end{aligned}$$

In Exercise 4.2.4 you will prove the following.

Proposition 4.2.9. *There is a natural isomorphism*

$$\text{CDiv}_{T_N}(X_\Sigma) \simeq \ker\left(\bigoplus_i M/M(\sigma_i) \rightarrow \bigoplus_{i<j} M/M(\sigma_i \cap \sigma_j)\right). \quad \square$$

For readers who know inverse limits (see [3, p. 103]), a more sophisticated description of $\text{CDiv}_{T_N}(X_\Sigma)$ comes from the directed set (Σ, \preceq) , where \preceq is the face relation. We get an inverse system where $\tau \preceq \sigma$ gives $M/M(\sigma) \rightarrow M/M(\tau)$, and the inverse limit gives an isomorphism

$$\text{CDiv}_{T_N}(X_\Sigma) \simeq \varprojlim_{\sigma \in \Sigma} M/M(\sigma).$$

The Toric Variety of a Polytope. In Chapter 2, we constructed the toric variety X_P of a full dimensional lattice polytope $P \subseteq M_{\mathbb{R}}$. If $M_{\mathbb{R}} \simeq \mathbb{R}^n$, this means that $\dim P = n$. As noted above, P has a canonical presentation

$$(4.2.4) \quad P = \{m \in M_{\mathbb{R}} \mid \langle m, u_F \rangle \geq -a_F \text{ for all facets } F \text{ of } P\},$$

where $a_F \in \mathbb{Z}$ and $u_F \in N$ is the inward-pointing facet normal that is the minimal generator of the ray $\rho_F = \text{Cone}(u_F)$. The normal fan Σ_P consists of cones σ_Q indexed by faces $Q \preceq P$, where

$$\sigma_Q = \text{Cone}(u_F \mid F \text{ contains } Q).$$

Proposition 2.3.6 implies that the fan Σ_P is complete. Furthermore, the vertices of P correspond to the maximal cones in $\Sigma_P(n)$, and the facets of P correspond to the rays in $\Sigma_P(1)$.

The ray generators of the normal fan Σ_P are the facet normals u_F . The corresponding prime divisors in X_P will be denoted D_F . Everything is now indexed by the facets F of P . The normal fan tells us the facet normals u_F in (4.2.4), but Σ_P cannot give us the integers a_F in (4.2.4). For these, we need the divisor

$$(4.2.5) \quad D_P = \sum_F a_F D_F.$$

As we will see in later chapters, this divisor plays a central role in the study of projective toric varieties. For now, we give the following useful result.

Proposition 4.2.10. *D_P is a Cartier divisor on X_P and $D_P \not\sim 0$.*

Proof. A vertex $v \in P$ corresponds to a maximal cone σ_v , and a ray ρ_F lies in $\sigma_v(1)$ if and only if $v \in F$. But $v \in F$ implies that $\langle v, u_F \rangle = -a_F$. Note also that $v \in M$ since P is a lattice polytope. Thus we have $v \in M$ such that $\langle v, u_F \rangle = -a_F$ for all $\rho_F \in \sigma_v(1)$, so that D_P is Cartier by Theorem 4.2.8. You will prove that $D_P \not\sim 0$ in Exercise 4.2.5. \square

In the notation of Theorem 4.2.8, m_{σ_v} is the vertex v . Thus the Cartier data of the Cartier divisor D_P is the set

$$(4.2.6) \quad \{m_{\sigma_v}\}_{\sigma_v \in \Sigma_P(n)} = \{v \mid v \text{ is a vertex of } P\}.$$

This is very satisfying and explains why the minus signs in (4.2.4) correspond to the minus signs in Theorem 4.2.8.

The divisor class $[D_P] \in \text{Pic}(X_P)$ also has a nice interpretation. If $D \sim D_P$, then $D = D_P + \text{div}(\chi^m)$ for some $m \in M$. In Proposition 2.3.7 we saw that P and its translate $P - m$ have the same normal fan and hence give the same toric variety, i.e., $X_P = X_{m+P}$. We also have

$$D = D_P + \text{div}(\chi^m) = D_{P-m}$$

(Exercise 4.2.5), so that the divisor class of D_P gives all translates of P .

The divisor D_P has many more wonderful properties. We will get a glimpse of this in §4.3 and learn the full power of D_P in Chapter 6 when we study ample divisors on toric varieties.

Support Functions. The Cartier data $\{m_\sigma\}_{\sigma \in \Sigma}$ that describes a torus-invariant Cartier divisor can be cumbersome to work with. Here we introduce a more efficient computational tool. Recall that Σ has support $|\Sigma| = \bigcup_{\sigma \in \Sigma} \sigma \subseteq N_{\mathbb{R}}$.

Definition 4.2.11. Let Σ be a fan in $N_{\mathbb{R}}$.

(a) A **support function** is a function $\varphi : |\Sigma| \rightarrow \mathbb{R}$ that is linear on each cone of Σ . The set of all support functions is denoted $\text{SF}(\Sigma)$.

(b) A support function φ is **integral with respect to the lattice** N if

$$\varphi(|\Sigma| \cap N) \subseteq \mathbb{Z}.$$

The set of all such support functions is denoted $\text{SF}(\Sigma, N)$.

Let $D = \sum_{\rho} a_{\rho} D_{\rho}$ be Cartier and let $\{m_{\sigma}\}_{\sigma \in \Sigma}$ be the Cartier data of D as in Theorem 4.2.8. Thus

$$(4.2.7) \quad \langle m_{\sigma}, u_{\rho} \rangle = -a_{\rho} \text{ for all } \rho \in \sigma(1).$$

We now describe Cartier divisors in terms of support functions.

Theorem 4.2.12. *Let Σ be a fan in $N_{\mathbb{R}}$.*

(a) *Given $D = \sum_{\rho} a_{\rho} D_{\rho}$ with Cartier data $\{m_{\sigma}\}_{\sigma \in \Sigma}$, the function*

$$\begin{aligned} \varphi_D : |\Sigma| &\longrightarrow \mathbb{R} \\ u &\longmapsto \varphi_D(u) = \langle m_{\sigma}, u \rangle \text{ when } u \in \sigma \end{aligned}$$

is a well-defined support function that is integral with respect to N .

(b) *$\varphi_D(u_{\rho}) = -a_{\rho}$ for all $\rho \in \Sigma(1)$, so that*

$$D = - \sum_{\rho} \varphi_D(u_{\rho}) D_{\rho}.$$

(c) *The map $D \mapsto \varphi_D$ induces an isomorphism*

$$\text{CDiv}_{T_N}(X_{\Sigma}) \simeq \text{SF}(\Sigma, N).$$

Proof. Theorem 4.2.8 tells us that each m_{σ} is unique modulo $\sigma^{\perp} \cap M$ and that $m_{\sigma} \equiv m_{\sigma'} \pmod{(\sigma \cap \sigma')^{\perp} \cap M}$. It follows easily that φ_D is well-defined. Also, φ_D is linear on each σ since $\varphi_D|_{\sigma}(u) = \langle m_{\sigma}, u \rangle$ for $u \in \sigma$, and it is integral with respect to N since $m_{\sigma} \in M$. This proves part (a), and part (b) follows from the definition of φ_D and (4.2.7).

It remains to prove part (c). First note that $\varphi_D \in \text{SF}(\Sigma, N)$ by part (a). Since $D, E \in \text{CDiv}_{T_N}(X_{\Sigma})$ and $k \in \mathbb{Z}$ imply that

$$\begin{aligned} \varphi_{D+E} &= \varphi_D + \varphi_E \\ \varphi_{kD} &= k\varphi_D, \end{aligned}$$

the map $\text{CDiv}_{T_N}(X_{\Sigma}) \rightarrow \text{SF}(\Sigma, N)$ is a homomorphism, and injectivity follows from part (b). To prove surjectivity, take $\varphi \in \text{SF}(\Sigma, N)$. Fix $\sigma \in \Sigma$. Since φ is integral with respect to N , it defines a \mathbb{N} -linear map $\varphi|_{\sigma \cap N} : \sigma \cap N \rightarrow \mathbb{Z}$, which extends to \mathbb{N} -linear map $\phi_{\sigma} : N_{\sigma} \rightarrow \mathbb{Z}$, where $N_{\sigma} = \text{Span}(\sigma) \cap N$. Since

$$\text{Hom}_{\mathbb{Z}}(N_{\sigma}, \mathbb{Z}) \simeq M/M(\sigma),$$

it follows that there is $m_{\sigma} \in M$ such that $\varphi|_{\sigma}(u) = \langle m_{\sigma}, u \rangle$ for $u \in \sigma$. Then $D = -\sum_{\rho} \varphi_D(u_{\rho}) D_{\rho}$ is a Cartier divisor that maps to φ . \square

In terms of support functions, the exact sequence of Theorem 4.2.1 becomes

$$(4.2.8) \quad M \longrightarrow \text{SF}(\Sigma, N) \longrightarrow \text{Pic}(X_{\Sigma}) \longrightarrow 0,$$

where $m \in M$ maps to the linear support function defined by $u \mapsto -\langle m, u \rangle$ and $\varphi \in \text{SF}(\Sigma, N)$ maps to the divisor class $[-\sum_{\rho} \varphi(u_{\rho}) D_{\rho}] \in \text{Pic}(X_{\Sigma})$. Be sure you understand the minus signs.

Here is an example of how to compute with support functions.

Example 4.2.13. The eight points $\pm e_1 \pm e_2 \pm e_3$ are the vertices of a cube in \mathbb{R}^3 . Taking the cones over the six faces gives a complete fan in \mathbb{R}^3 . Modify this fan by replacing $e_1 + e_2 + e_3$ with $e_1 + 2e_2 + 3e_3$. The resulting fan Σ has the surprising

property that $\text{Pic}(X_\Sigma) = 0$. In other words, X_Σ is a complete toric variety whose Cartier divisors are all principal.

We will prove $\text{Pic}(X_\Sigma) = 0$ by showing that all support functions for Σ are linear. Label the ray generators as follows, using coordinates for compactness:

$$\begin{aligned} u_1 &= (1, 2, 3), \quad u_2 = (1, -1, 1), \quad u_3 = (1, 1, -1), \quad u_4 = (-1, -1, 1) \\ u_5 &= (1, -1, -1), \quad u_6 = (-1, -1, 1), \quad u_7 = (-1, 1, -1), \quad u_8 = (-1, -1, -1). \end{aligned}$$

The ray generators are shown in Figure 4. The figure also includes three maximal cones of Σ :

$$\begin{aligned} \sigma_1 &= \text{Cone}(u_1, u_2, u_3, u_5) \\ \sigma_2 &= \text{Cone}(u_1, u_3, u_4, u_7) \\ \sigma_3 &= \text{Cone}(u_1, u_2, u_4, u_6). \end{aligned}$$

The shading in Figure 4 indicates $\sigma_1 \cap \sigma_2, \sigma_1 \cap \sigma_3, \sigma_2 \cap \sigma_3$. Besides $\sigma_1, \sigma_2, \sigma_3$, the fan Σ has three other maximal cones, which we call *left*, *down*, and *back*. Thus the cone *left* has ray generators u_2, u_5, u_6, u_8 , and similarly for the other two.

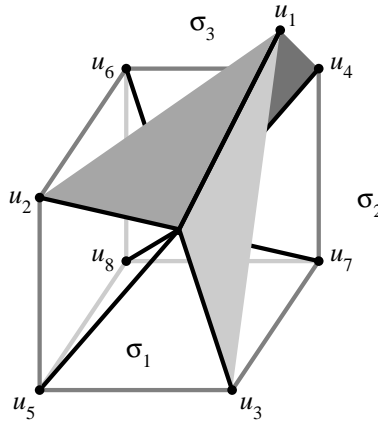

Figure 4. A fan Σ with $\text{Pic}(X_\Sigma) = 0$

Take $\varphi \in \text{SF}(\Sigma, \mathbb{Z}^3)$. We show that φ is linear as follows. Since $\varphi|_{\sigma_1}$ is linear, there is $m_1 \in \mathbb{Z}^3$ such that $\varphi(u) = \langle m_1, u \rangle$ for $u \in \sigma_1$. Hence the support function

$$u \mapsto \varphi(u) - \langle m_1, u \rangle$$

vanishes identically on σ_1 . Replacing φ with this support function, we may assume that $\varphi|_{\sigma_1} = 0$. Once we prove $\varphi = 0$ everywhere, it will follow that all support functions are linear, and then $\text{Pic}(X_\Sigma) = 0$ by (4.2.8).

Since $u_1, u_2, u_3, u_5 \in \sigma_1$ and φ vanishes on σ_1 , we have $\varphi(u_1) = \varphi(u_2) = \varphi(u_3) = \varphi(u_5) = 0$. It suffices to prove $\varphi(u_4) = \varphi(u_6) = \varphi(u_7) = \varphi(u_8) = 0$.

To do this, we use the fact that each maximal cone has four generators, which must satisfy a linear relation. Here are the cones and the corresponding relations:

cone	relation
σ_1	$2u_1 + 5u_5 = 4u_2 + 3u_3$
σ_2	$2u_1 + 4u_7 = 3u_3 + 5u_4$
σ_3	$2u_1 + 3u_6 = 4u_2 + 5u_4$
left	$u_2 + u_8 = u_5 + u_6$
down	$u_3 + u_8 = u_5 + u_7$
back	$u_4 + u_8 = u_6 + u_7$

Since φ is linear on each cone and $\varphi(u_1) = \varphi(u_2) = \varphi(u_3) = \varphi(u_5) = 0$, the second, third, fourth and fifth relations imply

$$4\varphi(u_7) = 5\varphi(u_4)$$

$$3\varphi(u_6) = 5\varphi(u_4)$$

$$\varphi(u_8) = \varphi(u_6)$$

$$\varphi(u_8) = \varphi(u_7).$$

The last two equations give $\varphi(u_6) = \varphi(u_7)$, and substituting these into the first two shows that $\varphi(u_4) = \varphi(u_6) = \varphi(u_7) = \varphi(u_8) = 0$. \diamond

Since the toric variety of a polytope P has the non-principal Cartier divisor D_P , it follows that the fan Σ of Example 4.2.13 is not the normal fan of *any* 3-dimensional lattice polytope. As we will see later, this implies that X_Σ is complete but not projective.

A full dimensional lattice polytope $P \subseteq M_{\mathbb{R}}$ leads to an interesting support function on the normal fan Σ_P .

Proposition 4.2.14. *Assume $P \subseteq M_{\mathbb{R}}$ is a full dimensional lattice polytope with normal fan Σ_P . Then the function $\varphi_P : N_{\mathbb{R}} \rightarrow \mathbb{R}$ defined by*

$$\varphi_P(u) = \min(\langle m, u \rangle \mid m \in P)$$

has the following properties:

- (a) φ_P is a support function for Σ_P and is integral with respect to N .
- (b) The divisor corresponding to φ_P is the divisor D_P defined in (4.2.5).

Proof. First note that minimum used in the definition of φ_P exists because P is compact. Now write

$$P = \{m \in M_{\mathbb{R}} \mid \langle m, u_F \rangle \geq -a_F \text{ for all facets } F \text{ of } P\}.$$

Then $D_P = \sum_F a_F D_F$ is Cartier by Proposition 4.2.10, and Theorem 4.2.12 shows that the corresponding support function maps u_F to $-a_F$.

It remains to show that $\varphi_P(u) \in \text{SF}(\Sigma_P)$ and $\varphi_P(u_F) = -a_F$. Recall that maximal cones of Σ_P correspond to vertices of P , where the vertex v gives the maximal cone $\sigma_v = \text{Cone}(u_F \mid v \in F)$. Take $u = \sum_{v \in F} \lambda_F u_F \in \sigma_v$, where $\lambda_F \geq 0$. Then $m \in P$ implies

$$(4.2.9) \quad \langle m, u \rangle = \sum_{v \in F} \lambda_F \langle m, u_F \rangle \geq - \sum_{v \in F} \lambda_F a_F.$$

Thus $\varphi_P(u) \geq - \sum_{v \in F} \lambda_F a_F$. Since equality occurs in (4.2.9) when $m = v$, we obtain

$$\varphi_P(u) = - \sum_{v \in F} \lambda_F a_F = \langle v, u \rangle.$$

This shows that $\varphi_P \in \text{SF}(\Sigma_P, N)$. Furthermore, when $v \in F$, we have $\varphi_P(u_F) = \langle v, u_F \rangle = -a_F$, as desired. \square

We will return to support functions in Chapter 6, where we will use them to give elegant criteria for a divisor to be ample or generated by its global sections.

Exercises for §4.2.

4.2.1. Prove the assertions made in Example 4.2.4.

4.2.2. Prove (4.2.3) and Proposition 4.2.7.

4.2.3. When Σ is complete, prove that $D = \sum_{\rho} a_{\rho} D_{\rho}$ is Cartier if and only if it satisfies condition (d)' stated in the discussion following Theorem 4.2.8.

4.2.4. Prove Proposition 4.2.9.

4.2.5. A lattice polytope P gives the toric variety X_P and the divisor D_P from (4.2.5).

(a) Prove that $D_P + \text{div}(\chi^m) = D_{P-m}$ for any $m \in M$.

(b) Prove that $D_P \not\sim 0$. Hint: The normal fan of P is complete.

4.2.6. Let D be a T_N -invariant Cartier divisor on X_{Σ} . By Theorem 4.2.8, D is determined by its Cartier data $\{m_{\sigma}\}_{\sigma \in \Sigma}$. Given any $m \in M$, show that $D + \text{div}(\chi^m)$ has Cartier data $\{m_{\sigma} - m\}_{\sigma \in \Sigma}$. Be sure to explain where the minus sign comes from.

4.2.7. Let X_{Σ} be the toric variety of the fan Σ . Prove the following consequences of the Orbit-Cone Correspondence (Theorem 3.2.6).

(a) $O(\sigma) = \bigcap_{\rho \in \sigma(1)} D_{\rho}$.

(b) Rays $u_{\rho_1}, \dots, u_{\rho_r} \in \Sigma(1)$ lie in a cone of Σ if and only if $D_{\rho_1} \cap \dots \cap D_{\rho_r} \neq \emptyset$.

4.2.8. Let Σ be a fan in $N_{\mathbb{R}} \simeq \mathbb{R}^n$ and assume that Σ has a cone of dimension n .

(a) Fix a cone $\sigma \in \Sigma$ of dimension n . Prove that

$$\text{Pic}(X_{\Sigma}) \simeq \{\varphi \in \text{SF}(\Sigma, N) \mid \varphi|_{\sigma} = 0\}.$$

(b) Explain how part (a) relates to Example 4.2.13.

(c) Use part (a) to give a different proof of Proposition 4.2.5.

4.2.9. Let σ be as in Example 4.2.4, but instead of using the lattice generated by e_1, e_2, e_3 , instead use $N = \mathbb{Z} \cdot \frac{1}{2b}e_1 + \mathbb{Z} \cdot \frac{1}{b}e_2 + \mathbb{Z} \cdot \frac{1}{a}e_3 + \mathbb{Z} \cdot \frac{1}{2b}(e_1 + e_2 + e_3)$, where a, b are relatively prime positive integers with $a > 1$. Prove that no multiple of $D_1 + D_2 + D_3 + D_4$ is Cartier. Hint: The first step will be to find the minimal generators (relative to N) of the edges of σ .

4.2.10. Let X_P be the toric variety of the octahedron $P = \text{Conv}(\pm e_1, \pm e_2, \pm e_3) \subseteq \mathbb{R}^3$.

(a) Show that $\text{Cl}(X_P) \simeq \mathbb{Z}^5 \oplus (\mathbb{Z}/2\mathbb{Z})^2$.

(b) Use support functions and the strategy of Example 4.2.13 to show that $\text{Pic}(X_P) \simeq \mathbb{Z}$.

4.2.11. In Exercise 4.1.5, you showed that the weighted projective space $\mathbb{P}(q_0, \dots, q_n)$ has class group $\text{Cl}(\mathbb{P}(q_0, \dots, q_n)) \simeq \mathbb{Z}$. Prove that $\text{Pic}(\mathbb{P}(q_0, \dots, q_n)) \subseteq \text{Cl}(\mathbb{P}(q_0, \dots, q_n))$ maps to the subgroup $m\mathbb{Z} \subseteq \mathbb{Z}$, where $m = \text{lcm}(q_0, \dots, q_n)$. Hint: Show that $\sum_{i=0}^n b_i D_i$ generates the class group, where $\sum_{i=0}^n b_i q_i = 1$. Also note that $m \in M_{\mathbb{Q}}$ lies in M if and only if $\langle m, u_i \rangle \in \mathbb{Z}$ for all i , where the u_i are from Exercise 4.1.5.

4.2.12. Let X_{Σ} be a smooth toric variety and let $\tau \in \Sigma$ be a cone of dimension ≥ 2 . This gives the orbit closure $V(\tau) = \overline{O(\tau)} \subseteq X_{\Sigma}$. In §3.3 we defined the blowup $\text{Bl}_{V(\tau)}(X_{\Sigma})$. Prove that

$$\text{Pic}(\text{Bl}_{V(\tau)}(X_{\Sigma})) \simeq \text{Pic}(X_{\Sigma}) \oplus \mathbb{Z}.$$

4.2.13. A nonzero polynomial $f = \sum_{m \in \mathbb{Z}^n} c_m x^m \in \mathbb{C}[x_1, \dots, x_n]$ has *Newton polytope*

$$P(f) = \text{Conv}(m \mid c_m \neq 0) \subset \mathbb{R}^n.$$

When $P(f)$ has dimension n , Proposition 4.2.14 tells us that the function $\varphi_{P(f)}(u) = \min(\langle m, u \rangle \mid m \in P(f))$ is the support function of a divisor on $X_{P(f)}$. Here we interpret $\varphi_{P(f)}$ as the *tropicalization* of f .

The *tropical semiring* $(\mathbb{R}, \oplus, \odot)$ has operations

$$\begin{aligned} a \oplus b &= \min(a, b) && \text{(tropical addition)} \\ a \odot b &= a + b && \text{(tropical multiplication)}. \end{aligned}$$

A *tropical polynomial* in real variables x_1, \dots, x_n is a finite tropical sum

$$F = c_1 \odot x_1^{a_{1,1}} \odot \cdots \odot x_n^{a_{1,n}} \oplus \cdots \oplus c_r \odot x_1^{a_{r,1}} \odot \cdots \odot x_n^{a_{r,n}}$$

where $c_i \in \mathbb{R}$ and $x_i^a = x_i \odot \cdots \odot x_i$ (a times). For a more compact representation, define a tropical monomial to be $x^m = x_1^{a_1} \odot \cdots \odot x_n^{a_n}$ for $m = (a_1, \dots, a_n) \in \mathbb{N}^n$. Then, using the tropical analog of summation notation, the tropical polynomial F is

$$F = \bigoplus_{i=1}^r c_i \odot x^{m_i}, \quad m_i = (a_{i,1}, \dots, a_{i,n}).$$

(a) Show that $F = \min_{1 \leq i \leq r} (c_i + a_{i,1}x_1 + \cdots + a_{i,n}x_n)$.

(b) The *tropicalization* of our original polynomial f is the tropical polynomial

$$F_f = \bigoplus_{c_m \neq 0} 0 \odot x^m.$$

Prove that $F_f = \varphi_{P(f)}$. (The 0 is explained as follows. In general, the coefficients of f are Puiseux series, and the tropicalization uses the order of vanishing of the coefficients. Here, the coefficients are nonzero constants, with order of vanishing 0.)

(c) The *tropical variety* of a tropical polynomial F is the set of points in \mathbb{R}^n where F is not linear. For $f = x + 2y + 3x^2 - xy^2 + 4x^2y$, compute the tropical variety of F_f and show that it consists of the rays in the normal fan of $P(f)$.

A nice introduction to tropical algebraic geometry can be found in [148].

§4.3. The Sheaf of a Torus-Invariant Divisor

If $D = \sum_{\rho} a_{\rho} D_{\rho}$ is a T_N -invariant divisor on the normal toric variety X_{Σ} , we get the sheaf $\mathcal{O}_{X_{\Sigma}}(D)$ defined in §4.0. We will study these sheaves in detail in Chapters 6 and 8. In this section we will focus primarily on global sections.

We begin with a classic example of the sheaf $\mathcal{O}_{X_{\Sigma}}(D)$.

Example 4.3.1. For \mathbb{P}^n , the divisors D_0, \dots, D_n correspond to the ray generators of the usual fan for \mathbb{P}^n . The computation $\text{Cl}(\mathbb{P}^n) \simeq \mathbb{Z}$ from Example 4.1.6 shows that $D_0 \sim D_1 \sim \dots \sim D_n$. These linear equivalences give isomorphisms

$$\mathcal{O}_{\mathbb{P}^n}(D_0) \simeq \mathcal{O}_{\mathbb{P}^n}(D_1) \simeq \dots \simeq \mathcal{O}_{\mathbb{P}^n}(D_n)$$

by Proposition 4.0.29. In the literature, these sheaves are denoted $\mathcal{O}_{\mathbb{P}^n}(1)$. Similarly, the sheaves $\mathcal{O}_{\mathbb{P}^n}(kD_i)$, $k \in \mathbb{Z}$, are denoted $\mathcal{O}_{\mathbb{P}^n}(k)$. \diamond

Global Sections. Let D be a T_N -invariant divisor on a toric variety X_{Σ} . We will give two descriptions of the global sections $\Gamma(X_{\Sigma}, \mathcal{O}_{X_{\Sigma}}(D))$. Here is the first.

Proposition 4.3.2. *If D is a T_N -invariant Weil divisor on X_{Σ} , then*

$$\Gamma(X_{\Sigma}, \mathcal{O}_{X_{\Sigma}}(D)) = \bigoplus_{\text{div}(\chi^m) + D \geq 0} \mathbb{C} \cdot \chi^m.$$

Proof. If $f \in \Gamma(X_{\Sigma}, \mathcal{O}_{X_{\Sigma}}(D))$, then $\text{div}(f) + D \geq 0$ implies $\text{div}(f)|_{T_N} \geq 0$ since $D|_{T_N} = 0$. Since $\mathbb{C}[M]$ is the coordinate ring of T_N , Proposition 4.0.16 implies $f \in \mathbb{C}[M]$. Thus

$$\Gamma(X_{\Sigma}, \mathcal{O}_{X_{\Sigma}}(D)) \subseteq \mathbb{C}[M].$$

Furthermore, $\Gamma(X_{\Sigma}, \mathcal{O}_{X_{\Sigma}}(D))$ is invariant under the T_N -action on $\mathbb{C}[M]$ since D is T_N -invariant. By Lemma 1.1.16, we obtain

$$\Gamma(X_{\Sigma}, \mathcal{O}_{X_{\Sigma}}(D)) = \bigoplus_{\chi^m \in \Gamma(X_{\Sigma}, \mathcal{O}_{X_{\Sigma}}(D))} \mathbb{C} \cdot \chi^m.$$

Since $\chi^m \in \Gamma(X_{\Sigma}, \mathcal{O}_{X_{\Sigma}}(D))$ if and only if $\text{div}(\chi^m) + D \geq 0$, we are done. \square

The Polyhedron of a Divisor. For $D = \sum_{\rho} a_{\rho} D_{\rho}$ and $m \in M$, $\text{div}(\chi^m) + D \geq 0$ is equivalent to

$$\langle m, u_{\rho} \rangle + a_{\rho} \geq 0 \quad \text{for all } \rho \in \Sigma(1),$$

which can be rewritten as

$$(4.3.1) \quad \langle m, u_{\rho} \rangle \geq -a_{\rho} \quad \text{for all } \rho \in \Sigma(1).$$

This explains the minus signs! To emphasize the underlying geometry, we define

$$(4.3.2) \quad P_D = \{m \in M_{\mathbb{R}} \mid \langle m, u_{\rho} \rangle \geq -a_{\rho} \text{ for all } \rho \in \Sigma(1)\}.$$

We say that P_D is a *polyhedron* since it is an intersection of finitely many closed half spaces. This looks very similar to the canonical presentation of a polytope (see (4.2.4), for example). However, the reader should be aware that P_D need not be a polytope, and even when it is a polytope, it need not be a lattice polytope. All of this will be explained in the examples given below.

For now, we simply note that (4.3.1) is equivalent to $m \in P_D \cap M$. This gives our second description of the global sections.

Proposition 4.3.3. *If D is a T_N -invariant Weil divisor on X_Σ , then*

$$\Gamma(X_\Sigma, \mathcal{O}_{X_\Sigma}(D)) = \bigoplus_{m \in P_D \cap M} \mathbb{C} \cdot \chi^m,$$

where $P_D \subseteq M_{\mathbb{R}}$ is the polyhedron defined in (4.3.2). \square

As noted above, a polyhedron is an intersection of finitely many closed half spaces. A polytope is a bounded polyhedron.

Examples. Here are some examples to illustrate the kinds of polyhedra that can occur in Proposition 4.3.3.

Example 4.3.4. The fan Σ for the blowup $\text{Bl}_0(\mathbb{C}^2)$ of \mathbb{C}^2 at the origin has ray generators $u_0 = e_1 + e_2$, $u_1 = e_1$, $u_2 = e_2$ and corresponding divisors D_0 , D_1 , D_2 . For the divisor $D = D_0 + D_1 + D_2$, a point $m = (x, y)$ lies in P_D if and only if

$$\begin{aligned} \langle m, u_0 \rangle \geq -1 &\iff x + y \geq -1 \\ \langle m, u_1 \rangle \geq -1 &\iff x \geq -1 \\ \langle m, u_2 \rangle \geq -1 &\iff y \geq -1. \end{aligned}$$

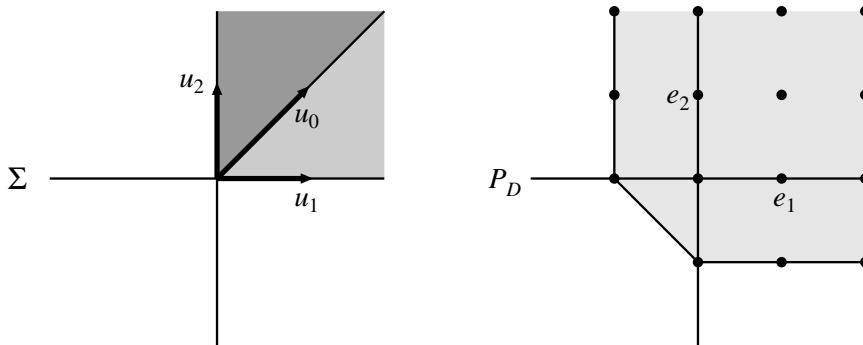

Figure 5. The fan Σ and the polyhedron P_D

The fan Σ and the polyhedron P_D are shown in Figure 5. Note that P_D is not bounded. By Proposition 4.3.3, the lattice points of P_D (the dots in Figure 5) give characters that form a basis of $\Gamma(\text{Bl}_0(\mathbb{C}^2), \mathcal{O}_{\text{Bl}_0(\mathbb{C}^2)}(D))$. \diamond

Example 4.3.5. The fan Σ_2 for the Hirzebruch surface \mathcal{H}_2 has ray generators $u_1 = -e_1 + 2e_2$, $u_2 = e_2$, $u_3 = e_1$, $u_4 = -e_2$. The corresponding divisors are D_1, D_2, D_3, D_4 , and Example 4.1.8 implies that the classes of D_1 and D_2 are a basis of $\text{Cl}(\mathcal{H}_2) \simeq \mathbb{Z}^2$.

Consider the divisor $aD_1 + D_2$, $a \in \mathbb{Z}$, and let $P_a \subseteq \mathbb{R}^2$ be the corresponding polyhedron, which is a polytope in this case. A point $m = (x, y)$ lies in P_a if and only if

$$\langle m, u_1 \rangle \geq -a \iff y \geq \frac{1}{2}x - \frac{a}{2}$$

$$\langle m, u_2 \rangle \geq -1 \iff y \geq -1$$

$$\langle m, u_3 \rangle \geq 0 \iff x \geq 0.$$

$$\langle m, u_4 \rangle \geq 0 \iff y \leq 0.$$

Figure 6 shows Σ_2 , together with shaded areas marked A, B, C . These are related

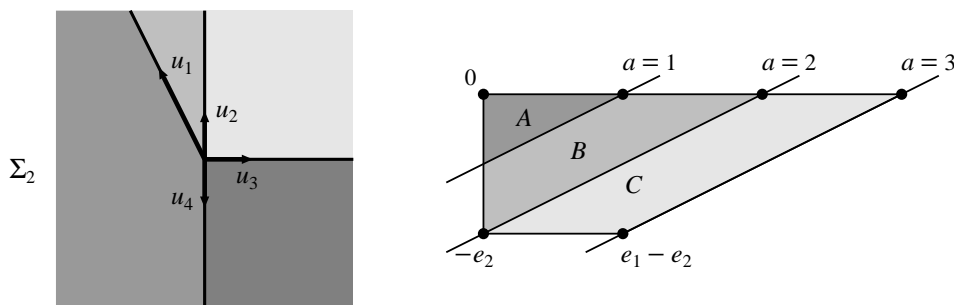

Figure 6. The fan Σ_2 and the polyhedra P_a

to the polygons P_a for $a = 1, 2, 3$ by the equations

$$P_1 = A$$

$$P_2 = A \cup B$$

$$P_3 = A \cup B \cup C.$$

Notice that as we increase a , the line $y = \frac{1}{2}x - \frac{a}{2}$ corresponding to u_1 moves to the right and makes the polytope bigger. In fact, you can see that Σ_2 is the normal fan of the lattice polytope P_a for any $a \geq 3$. For $a = 2$, we get a lattice polytope P_2 , but its normal fan is not Σ_2 —you can see how the “facet” with inward normal vector u_2 collapses to a point of P_2 . For $a = 1$, P_1 is not a lattice polytope since $-\frac{1}{2}e_2$ is a vertex. \diamond

Chapters 6 and 7 will explain how the geometry of the polyhedron P_D relates to the properties of the divisor D . In particular, we will see that the divisor $aD_1 + D_2$ from Example 4.3.5 is *ample* if and only if $a \geq 3$ since these are the only a 's for which Σ_2 is the normal fan P_a .

Example 4.3.6. By Example 4.3.1, the sheaf $\mathcal{O}_{\mathbb{P}^n}(k)$ can be written $\mathcal{O}_{\mathbb{P}^n}(kD_0)$, where the divisor D_0 corresponds to the ray generator u_0 from Example 4.1.6. It is straightforward to show that the polyhedron of $D = kD_0$ is

$$P_D = \begin{cases} \emptyset & k < 0 \\ k\Delta_n & k \geq 0, \end{cases}$$

where $\Delta_n \subseteq \mathbb{R}^n$ is the standard n -simplex. We can think of characters as Laurent monomials $t^m = t_1^{a_1} \cdots t_n^{a_n}$, where $m = (a_1, \dots, a_n)$. It follows that

$$\Gamma(\mathbb{P}^n, \mathcal{O}_{\mathbb{P}^n}(k)) \simeq \{f \in \mathbb{C}[t_1, \dots, t_n] \mid \deg(f) \leq k\}.$$

The *homogenization* of such a polynomial is

$$F = x_0^k f(x_1/x_0, \dots, x_n/x_0) \in \mathbb{C}[x_0, \dots, x_n].$$

In this way, we get an isomorphism

$$\Gamma(\mathbb{P}^n, \mathcal{O}_{\mathbb{P}^n}(k)) \simeq \{f \in \mathbb{C}[x_0, \dots, x_n] \mid f \text{ is homogeneous with } \deg(f) = k\}.$$

The toric interpretation of homogenization will be discussed in Chapter 5. \diamond

Example 4.3.7. Let X_P be the toric variety of a full dimensional lattice polytope $P \subseteq M_{\mathbb{R}}$. The facet presentation of P gives the Cartier divisor D_P defined in (4.2.5), and one checks easily that the polyhedron P_{D_P} is the polytope P that we began with (Exercise 4.3.1). It follows from Proposition 4.3.3 that

$$\Gamma(X_P, \mathcal{O}_{X_P}(D_P)) = \bigoplus_{m \in P \cap M} \mathbb{C} \cdot \chi^m.$$

Recall from Chapter 2 that the characters χ^m for $m \in P \cap M$ give the projective toric variety $X_{P \cap M}$. The divisor kD_P gives the polytope kP (Exercise 4.3.2), so that

$$\Gamma(X_P, \mathcal{O}_{X_P}(kD_P)) = \bigoplus_{m \in kP \cap M} \mathbb{C} \cdot \chi^m.$$

In Chapter 2 we proved that kP is very ample for k sufficiently large, in which case $X_{(kP) \cap M}$ is the toric variety X_P . So the characters χ^m that realize X_P as a projective variety come from global sections of $\mathcal{O}_{X_P}(kD_P)$. In Chapter 6, we will pursue these ideas when we study *ample* and *very ample* Cartier divisors.

Note also that $\dim \Gamma(X_P, \mathcal{O}_{X_P}(kD_P))$ gives number of lattice points in multiples of P . This will have important consequences in later chapters. \diamond

The operation sending a T_N -invariant Weil divisor $D \subseteq X_{\Sigma}$ to the polyhedron $P_D \subseteq M_{\mathbb{R}}$ defined in (4.3.2) has the following properties:

- $P_{kD} = kP_D$ for $k \geq 0$.
- $P_{D + \text{div}(\chi^m)} = P_D - m$.
- $P_D + P_E \subseteq P_{D+E}$.

You will prove these in Exercise 4.3.2. The multiple kP_D and Minkowski sum $P_D + P_E$ are defined in §2.2, and $P - m$ is translation.

Complete Fans. When the fan Σ is complete, we have the following finiteness result that you will prove in Exercise 4.3.3.

Proposition 4.3.8. *Let X_Σ be the toric variety of a complete fan Σ in $N_\mathbb{R}$. Then:*

- (a) $\Gamma(X_\Sigma, \mathcal{O}_{X_\Sigma}) = \mathbb{C}$, so the only morphisms $X_\Sigma \rightarrow \mathbb{C}$ are the constant ones.
- (b) P_D is a polytope for any T_N -invariant Weil divisor D on X_Σ .
- (c) $\Gamma(X_\Sigma, \mathcal{O}_{X_\Sigma}(D))$ has finite dimension as a vector space over \mathbb{C} for any Weil divisor on X_Σ .

The assertions of parts (a) and (c) are true more generally: if X is any complete variety and \mathcal{F} is a coherent sheaf on X , then $\Gamma(X, \mathcal{O}_X) = \mathbb{C}$ and $\dim \Gamma(X, \mathcal{F}) < \infty$ (see [152, Vol. 2, §VI.1.1 and §VI.3.4]).

Exercises for §4.3.

4.3.1. Prove the assertion $P_{D_p} = P$ made in Example 4.3.7.

4.3.2. Prove the properties of $D \mapsto P_D$ listed above.

4.3.3. Prove Proposition 4.3.8. Hint: For part (a), use completeness to show that $m = 0$ when $\langle m, u_\rho \rangle \geq 0$ for all ρ . For part (b), assume $M_\mathbb{R} = \mathbb{R}^n$ and suppose $m_i \in P_D$ satisfy $\|m_i\| \rightarrow \infty$. Then consider the points $\frac{m_i}{\|m_i\|}$ on the sphere $S^{n-1} \subseteq \mathbb{R}^n$.

4.3.4. Let Σ be a fan in $N_\mathbb{R}$ with convex support. Then $|\Sigma| \subseteq N_\mathbb{R}$ is a convex polyhedral cone with dual $|\Sigma|^\vee \subseteq M_\mathbb{R}$.

- (a) Prove that $|\Sigma|^\vee$ is the polyhedron associated to the divisor $D = 0$ on X_Σ .
- (b) Conclude that $\Gamma(X_\Sigma, \mathcal{O}_{X_\Sigma}) = \bigoplus_{m \in |\Sigma|^\vee \cap M} \mathbb{C} \cdot \chi^m$.
- (c) Use part (b) to prove part (a) of Proposition 4.3.8.

4.3.5. Example 4.3.5 studied divisors on the Hirzebruch surface \mathcal{H}_2 . This exercise will consider the divisors $D = D_4$ and $D' = D + D_2 = D_2 + D_4$.

- (a) Show that D' gives the same polygon P as D .
- (b) Since \mathcal{H}_2 is smooth, D and D' are Cartier. Compute their respective Cartier data $\{m_\sigma\}_{\sigma \in \Sigma_2(2)}$ and $\{m'_\sigma\}_{\sigma \in \Sigma_2(2)}$.
- (c) Show that $P = \text{Conv}(m_\sigma \mid \sigma \in \Sigma_2(2))$ and that $P \neq \text{Conv}(m'_\sigma \mid \sigma \in \Sigma_2(2))$.

Thus D and D' give the same polygon but differ in how their Cartier data relates to the polygon. In Chapter 6 we will use this to prove that $\mathcal{O}_{\mathcal{H}_2}(D)$ is generated by global sections while $\mathcal{O}_{\mathcal{H}_2}(D')$ has base points.

Homogeneous Coordinates

§5.0. Background: Quotients in Algebraic Geometry

Projective space \mathbb{P}^n is usually defined as the quotient

$$\mathbb{P}^n = (\mathbb{C}^{n+1} \setminus \{0\})/\mathbb{C}^*,$$

where \mathbb{C}^* acts on \mathbb{C}^{n+1} by scalar multiplication, i.e.,

$$\lambda \cdot (a_0, \dots, a_n) = (\lambda a_0, \dots, \lambda a_n).$$

The above representation defines \mathbb{P}^n as a *set*; making \mathbb{P}^n into a variety requires the notion of abstract variety introduced in Chapter 3. The main goal of this chapter is to prove that every toric variety has a similar quotient construction as a variety.

Group Actions. Let G be a group acting on a variety X . We always assume that for every $g \in G$, the map $\phi_g(x) = g \cdot x$ defines a morphism $\phi_g : X \rightarrow X$. When $X = \text{Spec}(R)$ is affine, $\phi_g : X \rightarrow X$ comes from a homomorphism $\phi_g^* : R \rightarrow R$. We define the *induced action* of G on R by

$$g \cdot f = \phi_{g^{-1}}^*(f)$$

for $f \in R$. In other words, $(g \cdot f)(x) = f(g^{-1} \cdot x)$ for all $x \in X$. You will check in Exercise 5.0.1 this gives an action of G on R . Thus we have two objects:

- The set G -orbits $X/G = \{G \cdot x \mid x \in X\}$.
- The ring of invariants $R^G = \{f \in R \mid g \cdot f = f \text{ for all } g \in G\}$.

To make X/G into an affine variety, we need to define its coordinate ring, i.e., we need to determine the “polynomial” functions on X/G . A key observation is that if $f \in R^G$, then

$$\bar{f}(G \cdot x) = f(x)$$

gives a well-defined function $\bar{f} : X/G \rightarrow \mathbb{C}$. Hence elements of G give obvious polynomial functions on X/G , which suggests that

$$\text{as an affine variety, } X/G = \text{Spec}(R^G).$$

As shown by the following examples, this works in some cases but fails in others.

Example 5.0.1. Let $\mu_2 = \{\pm 1\}$ act on $\mathbb{C}^2 = \text{Spec}(\mathbb{C}[s, t])$, where $-1 \in \mu_2$ acts by multiplication by -1 . Note that every orbit consists of two elements, with the exception of the orbit of the origin, which is the unique fixed point of the action.

The ring of invariants $\mathbb{C}[s, t]^{\mu_2} = \mathbb{C}[s^2, st, t^2]$ is the coordinate ring of the affine toric variety $\mathbf{V}(xz - y^2)$. Hence we get a map

$$\Phi : \mathbb{C}^2/\mu_2 \longrightarrow \text{Spec}(\mathbb{C}[s, t]^{\mu_2}) = \mathbf{V}(xz - y^2) \subseteq \mathbb{C}^3$$

where the orbit $\mu_2 \cdot (a, b)$ maps to (a^2, ab, b^2) . This is easily seen to be a bijection, so that $\text{Spec}(\mathbb{C}[s, t]^{\mu_2})$ is the perfect way to make \mathbb{C}^2/μ_2 into an affine variety.

This is actually an example of the toric morphism induced by changing the lattice—see Examples 1.3.17 and 1.3.19. \diamond

Example 5.0.2. Let \mathbb{C}^* act on $\mathbb{C}^4 = \text{Spec}(\mathbb{C}[x_1, x_2, x_3, x_4])$, where $\lambda \in \mathbb{C}^*$ acts via

$$\lambda \cdot (a_1, a_2, a_3, a_4) = (\lambda a_1, \lambda a_2, \lambda^{-1} a_3, \lambda^{-1} a_4).$$

In this case, the ring of invariants is

$$\mathbb{C}[x_1, x_2, x_3, x_4]^{\mathbb{C}^*} = \mathbb{C}[x_1 x_3, x_2 x_4, x_1 x_4, x_2 x_3],$$

which gives the map

$$\Phi : \mathbb{C}^4/\mathbb{C}^* \longrightarrow \text{Spec}(\mathbb{C}[x_1, x_2, x_3, x_4]^{\mathbb{C}^*}) = \mathbf{V}(xy - zw) \subseteq \mathbb{C}^4$$

where the orbit $\mathbb{C}^* \cdot (a_1, a_2, a_3, a_4)$ maps to $(a_1 a_3, a_2 a_4, a_1 a_4, a_2 a_3)$. Then we have (Exercise 5.0.2):

- Φ is surjective.
- If $p \in \mathbf{V}(xy - zw) \setminus \{0\}$, then $\Phi^{-1}(p)$ consists of a single \mathbb{C}^* -orbit which is closed in \mathbb{C}^4 .
- $\Phi^{-1}(0)$ consists of all \mathbb{C}^* -orbits contained in $\mathbb{C}^2 \times \{(0, 0)\} \cup \{(0, 0)\} \times \mathbb{C}^2$. Thus $\Phi^{-1}(0)$ consists of infinitely many \mathbb{C}^* -orbits.

This looks bad until we notice one further fact (Exercise 5.0.2):

- The fixed point $0 \in \mathbb{C}^4$ gives the unique closed orbit mapping to 0 under Φ .

If $(a, b) \neq (0, 0)$, then an example of a non-closed orbit is given by

$$\mathbb{C}^* \cdot (a, b, 0, 0) = \{(\lambda a, \lambda b, 0, 0) \mid \lambda \in \mathbb{C}^*\}$$

since $\lim_{\lambda \rightarrow 0} (\lambda a, \lambda b, 0, 0) = 0$. However, restricting to closed orbits gives

$$\{\text{closed } \mathbb{C}^*\text{-orbits}\} \simeq \mathbf{V}(xy - zw).$$

We will see that this is the best we can do for this group action. \diamond

Example 5.0.3. Let \mathbb{C}^* act on $\mathbb{C}^{n+1} = \text{Spec}(\mathbb{C}[x_0, \dots, x_n])$ by scalar multiplication. Then the ring of invariants consists of polynomials satisfying

$$f(\lambda x_0, \dots, \lambda x_n) = f(x_0, \dots, x_n)$$

for all $\lambda \in \mathbb{C}^*$. Such polynomials must be constant, so that

$$\mathbb{C}[x_0, \dots, x_n]^{\mathbb{C}^*} = \mathbb{C}.$$

It follows that the “quotient” is $\text{Spec}(\mathbb{C})$, which is just a point. The reason for this is that the only closed orbit is the orbit of the fixed point $0 \in \mathbb{C}^{n+1}$. \diamond

Examples 5.0.2 and 5.0.3 show what happens when there are not enough invariant functions to separate G -orbits.

The Ring of Invariants. When G acts on an affine variety $X = \text{Spec}(R)$, a natural question concerns the structure of the ring of invariants. The coordinate ring R is a finitely generated \mathbb{C} -algebra without nilpotents. Is the same true for R^G ? It clearly has no nilpotents since $R^G \subseteq R$. But is R^G finitely generated as a \mathbb{C} -algebra? This is related to Hilbert’s Fourteenth Problem, which was settled by a famous example of Nagata that R^G need not be a finitely generated \mathbb{C} -algebra! An exposition of Hilbert’s problem and Nagata’s example can be found in [45, Ch. 4].

If we assume that R^G is finitely generated, then $\text{Spec}(R^G)$ is an affine variety that is the “best” candidate for a quotient in the following sense.

Lemma 5.0.4. *Let G act on $X = \text{Spec}(R)$ such that R^G is a finitely generated \mathbb{C} -algebra, and let $\pi : X \rightarrow Y = \text{Spec}(R^G)$ be the morphism of affine varieties induced by the inclusion $R^G \subseteq R$. Then:*

(a) *Given any diagram*

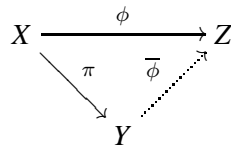

where ϕ is a morphism of affine varieties such that $\phi(g \cdot x) = \phi(x)$ for $g \in G$ and $x \in X$, there is a unique morphism $\bar{\phi}$ making the diagram commute, i.e., $\bar{\phi} \circ \pi = \phi$.

(b) *If X is irreducible, then Y is irreducible.*

(c) *If X is normal, then Y is normal.*

Proof. Suppose that $Z = \text{Spec}(S)$ and that ϕ is induced by $\phi^* : S \rightarrow R$. Then $\phi^*(S) \subseteq R^G$ follows easily from $\phi(g \cdot x) = \phi(x)$ for $g \in G, x \in X$. Thus ϕ^* factors uniquely as

$$S \xrightarrow{\bar{\phi}^*} R^G \xrightarrow{\pi^*} R.$$

The induced map $\bar{\phi} : Y \rightarrow Z$ clearly has the desired properties.

Part (b) is immediate since R^G is a subring of R . For part (c), let K be the field of fractions of R^G . If $a \in K$ is integral over R^G , then it is also integral over R and hence lies in R since R is normal. It follows that $a \in R \cap K$, which obviously equals R^G since G acts trivially on K . Thus R^G is normal. \square

This shows that $Y = \text{Spec}(R^G)$ has some good properties when R^G is finitely generated, but there are still some unanswered questions, such as:

- Is $\pi : X \rightarrow Y$ surjective?
- Does Y have the right topology? Ideally, we would like $U \subseteq Y$ to be open if and only if $\pi^{-1}(U) \subseteq X$ is open. (Exercise 5.0.3 explores how this works for group actions on topological spaces.)
- While Y is the best affine approximation of the quotient X/G , could there be a non-affine variety that is a better approximation?

We will see that the answers to these questions are all “yes” once we work with the correct type of group action.

Good Categorical Quotients. In order to get the best properties of a quotient map, we consider the general situation where G is a group acting on a variety X and $\pi : X \rightarrow Y$ is a morphism that is constant on G -orbits. Then we have the following definition.

Definition 5.0.5. Let G act on X and let $\pi : X \rightarrow Y$ be a morphism that is constant on G -orbits. Then π is a **good categorical quotient** if:

- (a) If $U \subseteq Y$ is open, then the natural map $\mathcal{O}_Y(U) \rightarrow \mathcal{O}_X(\pi^{-1}(U))$ induces an isomorphism

$$\mathcal{O}_Y(U) \simeq \mathcal{O}_X(\pi^{-1}(U))^G.$$

- (b) If $W \subseteq X$ is closed and G -invariant, then $\pi(W) \subseteq Y$ is closed.
 (c) If W_1, W_2 are closed, disjoint, and G -invariant in X , then $\pi(W_1)$ and $\pi(W_2)$ are disjoint in Y .

We often write a good categorical quotient as $\pi : X \rightarrow X//G$. Here are some properties of good categorical quotients.

Theorem 5.0.6. Let $\pi : X \rightarrow X//G$ be a good categorical quotient. Then:

- (a) Given any diagram

$$\begin{array}{ccc} X & \xrightarrow{\phi} & Z \\ & \searrow \pi & \nearrow \bar{\phi} \\ & X//G & \end{array}$$

where ϕ is a morphism such that $\phi(g \cdot x) = \phi(x)$ for $g \in G$ and $x \in X$, there is a unique morphism $\bar{\phi}$ making the diagram commute, i.e., $\bar{\phi} \circ \pi = \phi$.

- (b) π is surjective.
- (c) A subset $U \subseteq X//G$ is open if and only if $\pi^{-1}(U) \subseteq X$ is open.
- (d) If $U \subseteq X//G$ is open and nonempty, then $\pi|_{\pi^{-1}(U)} : \pi^{-1}(U) \rightarrow U$ is a good categorical quotient.
- (e) Given points $x, y \in X$, we have

$$\pi(x) = \pi(y) \iff \overline{G \cdot x} \cap \overline{G \cdot y} \neq \emptyset.$$

Proof. The proof of part (a) can be found in [45, Prop. 6.2]. The proofs of the remaining parts are left to the reader (Exercise 5.0.4). \square

Algebraic Actions. So far, we have allowed G to be an arbitrary group acting on X , assuming only that for every $g \in G$, the map $x \mapsto g \cdot x$ is a morphism $\phi_g : X \rightarrow X$. We now make the further assumption that G is an affine variety. To define this carefully, we first note that the group $\mathrm{GL}_n(\mathbb{C})$ of $n \times n$ invertible matrices with entries in \mathbb{C} is the affine variety

$$\mathrm{GL}_n(\mathbb{C}) = \{A \in \mathbb{C}^{n \times n} = \mathbb{C}^{n^2} \mid \det(A) \neq 0\}.$$

A subgroup $G \subseteq \mathrm{GL}_n(\mathbb{C})$ is an *affine algebraic group* if it is also a subvariety of $\mathrm{GL}_n(\mathbb{C})$. Examples include $\mathrm{GL}_n(\mathbb{C})$, $\mathrm{SL}_n(\mathbb{C})$, $(\mathbb{C}^*)^n$, and finite groups.

If G is an affine algebraic group, then the connected component of the identity, denoted G° , has the following properties (see [92, 7.3]):

- G° is a normal subgroup of finite index in G .
- G° is an irreducible affine algebraic group.

An affine algebraic group G acts *algebraically* on a variety X if the G -action $(g, x) \mapsto g \cdot x$ defines a morphism

$$G \times X \rightarrow X.$$

Examples of algebraic actions include toric varieties since the torus $T_N \subseteq X$ acts algebraically on X . Examples 5.0.1, 5.0.2 and 5.0.3 are also algebraic actions.

Algebraic actions have the property that G -orbits are constructible sets in X . This has the following nice consequence for good categorical quotients.

Proposition 5.0.7. *Let an affine algebraic group G act algebraically on a variety X , and assume that a good categorical quotient $\pi : X \rightarrow X//G$ exists. Then:*

- (a) If $p \in X//G$, then $\pi^{-1}(p)$ contains a unique closed G -orbit.
- (b) π induces a bijection

$$\{\text{closed } G\text{-orbits in } X\} \simeq X//G.$$

Proof. For part (a), first note that uniqueness follows immediately from part (e) of Theorem 5.0.6. To prove the existence of a closed orbit in $\pi^{-1}(p)$, let $G^\circ \subseteq G$ be

the connected component of the identity. Then $\pi^{-1}(p)$ is stable under G° , so we can pick an orbit $G^\circ \cdot x \subset \pi^{-1}(p)$ such that $\overline{G^\circ \cdot x}$ has minimal dimension.

Note that $\overline{G^\circ \cdot x}$ is irreducible since G° is irreducible, and since $G^\circ \cdot x$ is constructible, there is a nonempty Zariski open subset U of $\overline{G^\circ \cdot x}$ such that $U \subseteq G^\circ \cdot x$. If $G^\circ \cdot x$ is not closed, then $\overline{G^\circ \cdot x}$ contains an orbit $G^\circ \cdot y \neq G^\circ \cdot x$. Thus

$$G^\circ \cdot y \subseteq \overline{G^\circ \cdot x} \setminus G^\circ \cdot x \subseteq \overline{G^\circ \cdot x} \setminus U.$$

However, $\overline{G^\circ \cdot x}$ is irreducible, so that

$$\dim(\overline{G^\circ \cdot x} \setminus U) < \dim \overline{G^\circ \cdot x}.$$

Hence $\overline{G^\circ \cdot y}$ has strictly smaller dimension, a contradiction. Thus $G^\circ \cdot x$ is closed. If g_1, \dots, g_t are coset representatives of G/G° , then

$$G \cdot x = \bigcup_{i=1}^t g_i G^\circ \cdot x$$

shows that $G \cdot x$ is also closed. This proves part (a) of the proposition, and part (b) follows immediately from part (a) and the surjectivity of π . \square

For the rest of the section, we will always assume that G is an affine algebraic group acting algebraically on a variety X .

Geometric Quotients. The best quotients are those where points are orbits. For good categorical quotients, this condition is captured by requiring that orbits be closed. Here is the precise result.

Proposition 5.0.8. *Let $\pi : X \rightarrow X//G$ be a good categorical quotient. Then the following are equivalent:*

- (a) All G -orbits are closed in X .
- (b) Given points $x, y \in X$, we have

$$\pi(x) = \pi(y) \iff x \text{ and } y \text{ lie in the same } G\text{-orbit.}$$

- (c) π induces a bijection

$$\{G\text{-orbits in } X\} \simeq X//G.$$

- (d) The image of the morphism $G \times X \rightarrow X \times X$ defined by $(g, x) \mapsto (g \cdot x, x)$ is the fiber product $X \times_{X//G} X$.

Proof. This follows easily from Theorem 5.0.6 and Proposition 5.0.7. We leave the details to the reader (Exercise 5.0.5). \square

In general, a good categorical quotient is called a *geometric quotient* if it satisfies the conditions of Proposition 5.0.8. We write a geometric quotient as $\pi : X \rightarrow X/G$ since points in X/G correspond bijectively to G -orbits in X .

We have yet to give an example of a good categorical or geometric quotient. For instance, it is not clear that Examples 5.0.1, 5.0.2 and 5.0.3 satisfy Definition 5.0.5. Fortunately, once we restrict to the right kind of algebraic group, examples become abundant.

Reductive Groups. An affine algebraic group G is called *reductive* if its maximal connected solvable subgroup is a torus. Examples of reductive groups include finite groups, tori, and semisimple groups such as $\mathrm{SL}_n(\mathbb{C})$.

For us, actions by reductive groups have the following key properties.

Proposition 5.0.9. *Let G be a reductive group acting algebraically on an affine variety $X = \mathrm{Spec}(R)$. Then*

- (a) R^G is a finitely generated \mathbb{C} -algebra.
- (b) The morphism $\pi : X \rightarrow \mathrm{Spec}(R^G)$ induced by $R^G \subseteq R$ is a good categorical quotient.

Proof. See [45, Prop. 3.1] for part (a) and [45, Thm. 6.1] for part (b). □

In the situation of Proposition 5.0.9, we can write $\mathrm{Spec}(R)//G = \mathrm{Spec}(R^G)$. Examples 5.0.1, 5.0.2 and 5.0.3 involve reductive groups acting on affine varieties. Hence these are good categorical quotients that have all of the properties listed in Theorem 5.0.6 and Proposition 5.0.7. Furthermore, Example 5.0.1 (the action of μ_2 on \mathbb{C}^2) is a geometric quotient. This last example generalizes as follows.

Example 5.0.10. Given a strongly convex rational polyhedral cone $\sigma \subseteq N_{\mathbb{R}}$ and a sublattice $N' \subseteq N$ of finite index, part (b) of Proposition 1.3.18 implies that the finite group $G = N/N'$ acts on $U_{\sigma, N'}$ such that the induced map on coordinate rings is given by

$$\mathbb{C}[\sigma^{\vee} \cap M] \xrightarrow{\sim} \mathbb{C}[\sigma^{\vee} \cap M']^G \subseteq \mathbb{C}[\sigma^{\vee} \cap M].$$

It follows that $\phi : U_{\sigma, N'} \rightarrow U_{\sigma, N}$ is a good categorical quotient. In fact, ϕ is a geometric quotient since the G -orbits are finite and hence closed. This completes the proof of part (c) of Proposition 1.3.18. ◇

Almost Geometric Quotients. Let us examine Examples 5.0.2 and 5.0.3 more closely. As noted above, both give good categorical quotients. However:

- (Example 5.0.3) Here we have the quotient

$$\mathbb{C}^{n+1} // \mathbb{C}^* = \mathrm{Spec}(\mathbb{C}[x_0, \dots, x_n]^{\mathbb{C}^*}) = \mathrm{Spec}(\mathbb{C}) = \{\mathrm{pt}\}.$$

So the “good” categorical quotient $\mathbb{C}^{n+1} \rightarrow \mathbb{C}^{n+1} // \mathbb{C}^* = \{\mathrm{pt}\}$ is really bad.

- (Example 5.0.2) In this case, the quotient is

$$\pi : \mathbb{C}^4 \rightarrow \mathbb{C}^4 // \mathbb{C}^* = \mathbf{V}(xy - zw).$$

Let $U = \mathbf{V}(xy - zw) \setminus \{0\}$ and $U_0 = \pi^{-1}(U)$. Then $\pi|_{U_0} : U_0 \rightarrow U$ is a good categorical quotient by Theorem 5.0.6, and by Example 5.0.2, orbits of elements

in U_0 are closed in \mathbb{C}^4 . Then $\pi|_{U_0}$ is a geometric quotient by Proposition 5.0.8, so that $\mathbb{C}^4 // \mathbb{C}^* = \mathbf{V}(xy - zw)$ is a geometric quotient outside of the origin.

The difference between these two examples is that the second is very close to being a geometric quotient. Here is a result that describes this phenomenon in general.

Proposition 5.0.11. *Let $\pi : X \rightarrow X // G$ be a good categorical quotient. Then the following are equivalent:*

- (a) X has a G -invariant Zariski dense open subset U_0 such that $G \cdot x$ is closed in X for all $x \in U_0$.
- (b) $X // G$ has a Zariski dense open subset U such that $\pi|_{\pi^{-1}(U)} : \pi^{-1}(U) \rightarrow U$ is a geometric quotient.

Proof. Given U_0 satisfying (a), then $W = X \setminus U_0$ is closed and G -invariant. For $x \in U_0$, the orbit $G \cdot x \subset U_0$ is also closed and G -invariant. These are disjoint, which implies $\pi(x) \notin \pi(W)$ since π is a good categorical quotient. Since π is onto, we see that $X // G = \pi(U_0) \cup \pi(W)$ is a disjoint union. If we set $U = \pi(U_0)$, then $U_0 = \pi^{-1}(U)$. Note also that U is open since $\pi(W)$ is closed and Zariski dense since U_0 is Zariski dense in X . Then $\phi|_{U_0} : U_0 \rightarrow U$ is a good categorical quotient by Theorem 5.0.6, and by assumption, orbits of elements in U_0 are closed in \mathbb{C}^4 and hence in U_0 . It follows that $\phi|_{U_0}$ is a geometric quotient by Proposition 5.0.8.

The proof going the other way is similar and is omitted (Exercise 5.0.6). \square

In general, a good categorical quotient is called an *almost geometric quotient* if it satisfies the conditions of Proposition 5.0.11. Example 5.0.2 is an almost geometric quotient while Example 5.0.3 is not.

Constructing Quotients. Now that we can handle affine quotients in the reductive case, the next step is to handle more general quotients. Here is a useful result.

Proposition 5.0.12. *Let G act on X and let $\pi : X \rightarrow Y$ be a morphism of varieties that is constant on G -orbits. If Y has an open cover $Y = \bigcup_{\alpha} V_{\alpha}$ such that*

$$\pi|_{\pi^{-1}(V_{\alpha})} : \pi^{-1}(V_{\alpha}) \longrightarrow V_{\alpha}$$

is a good categorical quotient for every α , then $\pi : X \rightarrow Y$ is a good categorical quotient.

Proof. The key point is that the properties listed in Definition 5.0.5 can be checked locally. We leave the details to the reader (Exercise 5.0.7). \square

Example 5.0.13. Consider a lattice N and a sublattice $N' \subseteq N$ of finite index, and let Σ be a fan in $N'_{\mathbb{R}} = N_{\mathbb{R}}$. This gives a toric morphism

$$\phi : X_{\Sigma, N'} \rightarrow X_{\Sigma, N}.$$

By Proposition 1.3.18, the finite group $G = N/N'$ is the kernel of $T_{N'} \rightarrow T_N$, so that G acts on $X_{\Sigma, N'}$. Since

$$\phi^{-1}(U_{\sigma, N}) = U_{\sigma, N'}$$

for $\sigma \in \Sigma$, Example 5.0.10 and Propostion 5.0.12 imply that ϕ is a geometric quotient. This strengthens the result proved in Proposition 3.3.7. \diamond

It is sometimes possible to construct the quotient of X by G by taking rings of invariants for a suitable affine open cover. If the local quotients patch together to form a separated variety Y , then the resulting morphism $\pi : X \rightarrow Y$ is a good categorical quotient by Proposition 5.0.12. Here are two examples that illustrate this strategy.

Example 5.0.14. Let \mathbb{C}^* act on $\mathbb{C}^2 \setminus \{0\}$ by scalar multiplication, where $\mathbb{C}^2 = \text{Spec}(\mathbb{C}[x_0, x_1])$. Then $\mathbb{C}^2 \setminus \{0\} = U_0 \cup U_1$, where

$$\begin{aligned} U_0 &= \mathbb{C}^2 \setminus \mathbf{V}(x_0) = \text{Spec}(\mathbb{C}[x_0^{\pm 1}, x_1]) \\ U_1 &= \mathbb{C}^2 \setminus \mathbf{V}(x_1) = \text{Spec}(\mathbb{C}[x_0, x_1^{\pm 1}]) \\ U_0 \cap U_1 &= \mathbb{C}^2 \setminus \mathbf{V}(x_0 x_1) = \text{Spec}(\mathbb{C}[x_0^{\pm 1}, x_1^{\pm 1}]). \end{aligned}$$

The rings of invariants are

$$\begin{aligned} \mathbb{C}[x_0^{\pm 1}, x_1]^{\mathbb{C}^*} &= \mathbb{C}[x_1/x_0] \\ \mathbb{C}[x_0, x_1^{\pm 1}]^{\mathbb{C}^*} &= \mathbb{C}[x_0/x_1] \\ \mathbb{C}[x_0^{\pm 1}, x_1^{\pm 1}]^{\mathbb{C}^*} &= \mathbb{C}[(x_1/x_0)^{\pm 1}]. \end{aligned}$$

It follows that the $V_i = U_i // \mathbb{C}^*$ glue together in the usual way to create \mathbb{P}^1 . Since \mathbb{C}^* -orbits are closed in $\mathbb{C}^2 \setminus \{0\}$, it follows that

$$\mathbb{P}^1 = (\mathbb{C}^2 \setminus \{0\}) / \mathbb{C}^*$$

is a geometric quotient. \diamond

This example generalizes to show that

$$\mathbb{P}^n = (\mathbb{C}^{n+1} \setminus \{0\}) / \mathbb{C}^*$$

is a good geometric quotient when \mathbb{C}^* acts on \mathbb{C}^{n+1} by scalar multiplication. At the beginning of the section, we wrote this quotient as a set-theoretic construction. It is now an algebro-geometric construction.

Our second example shows the importance of being separated.

Example 5.0.15. Let \mathbb{C}^* act on $\mathbb{C}^2 \setminus \{0\}$ by $\lambda(a, b) = (\lambda a, \lambda^{-1} b)$. Then $\mathbb{C}^2 \setminus \{0\} = U_0 \cup U_1$, where U_0, U_1 and $U_0 \cap U_1$ are as in Example 5.0.14. Here, the rings of

invariants are

$$\begin{aligned}\mathbb{C}[x_0^{\pm 1}, x_1]^{\mathbb{C}^*} &= \mathbb{C}[x_0 x_1] \\ \mathbb{C}[x_0, x_1^{\pm 1}]^{\mathbb{C}^*} &= \mathbb{C}[x_0 x_1] \\ \mathbb{C}[x_0^{\pm 1}, x_1^{\pm 1}]^{\mathbb{C}^*} &= \mathbb{C}[(x_0 x_1)^{\pm 1}].\end{aligned}$$

Gluing together $V_i = U_i // \mathbb{C}^*$ along $U_0 \cap U_1 // \mathbb{C}^*$ gives the variety obtained from two copies of \mathbb{C} by identifying all nonzero points. This is the non-separated variety constructed in Example 3.0.15.

In Exercise 5.0.8 you will draw a picture of the \mathbb{C}^* -orbits that explains why the quotient cannot be separated in this example. \diamond

In this book, we usually use the word “variety” to mean “separated variety”. For example, when we say that $\pi : X \rightarrow Y$ is a good categorical or geometric quotient, we always assume that X and Y are separated. So Example 5.0.15 is *not* a good categorical quotient. In algebraic geometry, most operations on varieties preserve separatedness. Quotient constructions are one of the few exceptions where care has to be taken to check that the resulting variety is separated.

Exercises for §5.0.

5.0.1. Let G act on an affine variety $X = \text{Spec}(R)$ such that $\phi_g(x) = g \cdot x$ is a morphism for all $g \in G$.

- Show that $g \cdot f = \phi_{g^{-1}}^*(f)$ defines an action of G on R . Be sure you understand why the inverse is necessary.
- The *evaluation map* $R \times X \rightarrow \mathbb{C}$ is defined by $(f, x) \mapsto f(x)$. Show that this map is invariant under the action of G on $R \times X$ given by $g \cdot (f, x) = (g \cdot f, g \cdot x)$.

5.0.2. Prove the claims made in Example 5.0.2.

5.0.3. Let G be a group acting on a Hausdorff topological space, and let X/G be the set of G -orbits. Define $\pi : X \rightarrow X/G$ by $\pi(x) = G \cdot x$. The *quotient topology* on X/G is defined by saying that $U \subseteq X/G$ is open if and only if $\pi^{-1}(U) \subseteq X$ is open.

- Prove that if X/G is Hausdorff, then the G -orbits are closed subsets of X .
- Prove that if $W \subseteq X$ is closed and G -invariant, then $\pi(W) \subseteq X/G$ is closed.
- Prove that if W_1, W_2 are closed, disjoint, and G -invariant in X , then $\pi(W_1)$ and $\pi(W_2)$ are disjoint in X/G .

5.0.4. Prove parts (b), (c), (d) and (e) of Theorem 5.0.6. Hint for part (b): Part (a) of Definition 5.0.5 implies that $\mathcal{O}_{X//G}(U)$ injects into $\mathcal{O}_X(\pi^{-1}(U))$ for all open sets $U \subseteq X//G$. Use this to prove that $\pi(X)$ is Zariski dense in $X//G$. Then use part (b) of Definition 5.0.5.

5.0.5. Prove Proposition 5.0.8.

5.0.6. Complete the proof of Proposition 5.0.11.

5.0.7. Prove Proposition 5.0.12.

5.0.8. Consider the \mathbb{C}^* action on $\mathbb{C}^2 \setminus \{0\}$ described in Example 5.0.15.

- (a) Show that with two exceptions, the \mathbb{C}^* -orbits are the hyperbolas $x_1x_2 = a$, $a \neq 0$. Also describe the two remaining \mathbb{C}^* -orbits.
- (b) Give an intuitive explanation, with picture, to show that the “limit” of the orbits $x_1x_2 = a$ as $a \rightarrow 0$ consists of two distinct orbits.
- (c) Explain how part (b) relates to the non-separated quotient constructed in the example.

5.0.9. Give an example of a reductive G -action on an affine variety X such that X has a nonempty G -invariant affine open set $U \subseteq X$ with the property that the induced map $U//G \rightarrow X//G$ is not an inclusion.

5.0.10. Let a finite group G act on X . Then a good categorical quotient $\pi : X \rightarrow X//G$ exists since finite groups are reductive. Explain why π is a good geometric quotient.

§5.1. Quotient Constructions of Toric Varieties

Let X_Σ be the toric variety of a fan Σ in $N_{\mathbb{R}}$. The goal of this section is to construct X_Σ as an almost geometric quotient

$$X_\Sigma \simeq (\mathbb{C}^r \setminus Z)//G$$

for an appropriate choice of affine space \mathbb{C}^r , exceptional set $Z \subseteq \mathbb{C}^r$, and reductive group G . We will use our standard notation, where each $\rho \in \Sigma(1)$ gives a minimal generator $u_\rho \in \rho \cap N$ and a T_N -invariant prime divisor $D_\rho \subseteq X_\Sigma$.

No Torus Factors. Toric varieties with no torus factors have the nicest quotient constructions. Recall from Proposition 3.3.9 that X_Σ has no torus factors when $N_{\mathbb{R}}$ is spanned by u_ρ , $\rho \in \Sigma(1)$, and when this happens, Theorem 4.1.3 gives the short exact sequence

$$0 \longrightarrow M \longrightarrow \bigoplus_{\rho} \mathbb{Z} D_\rho \longrightarrow \text{Cl}(X_\Sigma) \longrightarrow 0,$$

where $m \in M$ maps to $\text{div}(\chi^m) = \sum_{\rho} \langle m, u_\rho \rangle D_\rho$ and $\text{Cl}(X_\Sigma)$ is the class group defined in §4.0. We use the convention that in expressions such as \bigoplus_{ρ} , \sum_{ρ} and \prod_{ρ} , the index ρ ranges over all $\rho \in \Sigma(1)$.

We write the above sequence more compactly as

$$(5.1.1) \quad 0 \longrightarrow M \longrightarrow \mathbb{Z}^{\Sigma(1)} \longrightarrow \text{Cl}(X_\Sigma) \longrightarrow 0.$$

Applying $\text{Hom}_{\mathbb{Z}}(-, \mathbb{C}^*)$ gives

$$1 \longrightarrow \text{Hom}_{\mathbb{Z}}(\text{Cl}(X_\Sigma), \mathbb{C}^*) \longrightarrow \text{Hom}_{\mathbb{Z}}(\mathbb{Z}^{\Sigma(1)}, \mathbb{C}^*) \longrightarrow \text{Hom}_{\mathbb{Z}}(M, \mathbb{C}^*) \longrightarrow 1,$$

which remains a short exact sequence since $\text{Hom}_{\mathbb{Z}}(-, \mathbb{C}^*)$ is left exact and \mathbb{C}^* is divisible. We have natural isomorphisms

$$\text{Hom}_{\mathbb{Z}}(\mathbb{Z}^{\Sigma(1)}, \mathbb{C}^*) \simeq (\mathbb{C}^*)^{\Sigma(1)}$$

$$\text{Hom}_{\mathbb{Z}}(M, \mathbb{C}^*) \simeq T_N,$$

and we define the group G by

$$G = \text{Hom}_{\mathbb{Z}}(\text{Cl}(X_\Sigma), \mathbb{C}^*).$$

This gives the short exact sequence of affine algebraic groups

$$(5.1.2) \quad 1 \longrightarrow G \longrightarrow (\mathbb{C}^*)^{\Sigma(1)} \longrightarrow T_N \longrightarrow 1.$$

The Group G . The group G defined above will appear in the quotient construction of the toric variety X_Σ . For the time being, we assume that X_Σ has no torus factors.

The following result describes the structure of G and gives explicit equations for G as a subgroup of the torus $(\mathbb{C}^*)^{\Sigma(1)}$.

Lemma 5.1.1. *Let $G \subseteq (\mathbb{C}^*)^{\Sigma(1)}$ be as in (5.1.2). Then:*

- (a) $\text{Cl}(X_\Sigma)$ is the character group of G .
- (b) G° is a torus, so that G is isomorphic to a product of a torus and a finite abelian group. In particular, G is reductive.
- (c) Given a basis e_1, \dots, e_n of M , we have

$$\begin{aligned} G &= \{ (t_\rho) \in (\mathbb{C}^*)^{\Sigma(1)} \mid \prod_\rho t_\rho^{\langle m, u_\rho \rangle} = 1 \text{ for all } m \in M \} \\ &= \{ (t_\rho) \in (\mathbb{C}^*)^{\Sigma(1)} \mid \prod_\rho t_\rho^{\langle e_i, u_\rho \rangle} = 1 \text{ for } 1 \leq i \leq n \}. \end{aligned}$$

Proof. Since $\text{Cl}(X_\Sigma)$ is a finitely generated abelian group, $\text{Cl}(X_\Sigma) \simeq \mathbb{Z}^\ell \times H$, where H is a finite abelian group. Then

$$G = \text{Hom}_{\mathbb{Z}}(\text{Cl}(X_\Sigma), \mathbb{C}^*) \simeq \text{Hom}_{\mathbb{Z}}(\mathbb{Z}^\ell \times H, \mathbb{C}^*) \simeq (\mathbb{C}^*)^\ell \times \text{Hom}_{\mathbb{Z}}(H, \mathbb{C}^*).$$

This proves part (b) since $\text{Hom}_{\mathbb{Z}}(H, \mathbb{C}^*)$ is a finite abelian group. For part (a), note that $\alpha \in \text{Cl}(X_\Sigma)$ gives the map that sends $g \in G = \text{Hom}_{\mathbb{Z}}(\text{Cl}(X_\Sigma), \mathbb{C}^*)$ to $g(\alpha) \in \mathbb{C}^*$. Thus elements of $\text{Cl}(X_\Sigma)$ give characters on G , and the above isomorphisms make it easy to see that all characters of G arise this way.

For part (c), the first description of G follows from (5.1.2) since $M \rightarrow \mathbb{Z}^{\Sigma(1)}$ is defined by $m \in M \mapsto (\langle m, u_\rho \rangle) \in \mathbb{Z}^{\Sigma(1)}$, and the second description follows immediately. \square

Example 5.1.2. The ray generators of the fan for \mathbb{P}^n are $u_0 = -\sum_{i=1}^n e_i, u_1 = e_1, \dots, u_n = e_n$. By Lemma 5.1.1, $(t_0, \dots, t_n) \in (\mathbb{C}^*)^{n+1}$ lies in G if and only if

$$t_0^{\langle m, -e_1 - \dots - e_n \rangle} t_1^{\langle m, e_1 \rangle} \dots t_n^{\langle m, e_n \rangle} = 1$$

for all $m \in M = \mathbb{Z}^n$. Taking m equal to e_1, \dots, e_n , we see that G is defined by

$$t_0^{-1} t_1 = \dots = t_0^{-1} t_n = 1.$$

Thus

$$G = \{ (\lambda, \dots, \lambda) \mid \lambda \in \mathbb{C}^* \} \simeq \mathbb{C}^*,$$

which is the action of \mathbb{C}^* on \mathbb{C}^{n+1} given by scalar multiplication. \diamond

Example 5.1.3. The fan for $\mathbb{P}^1 \times \mathbb{P}^1$ has ray generators $u_1 = e_1, u_2 = -e_1, u_3 = e_2, u_4 = -e_2$ in $N = \mathbb{Z}^2$. By Lemma 5.1.1, $(t_1, t_2, t_3, t_4) \in (\mathbb{C}^*)^4$ lies in G if and only if

$$t_1^{\langle m, e_1 \rangle} t_2^{\langle m, -e_1 \rangle} t_3^{\langle m, e_2 \rangle} t_4^{\langle m, -e_2 \rangle} = 1$$

for all $m \in M = \mathbb{Z}^2$. Taking m equal to e_1, e_2 , we obtain

$$t_1 t_2^{-1} = t_3 t_4^{-1} = 1.$$

Thus

$$G = \{(\mu, \mu, \lambda, \lambda) \mid \mu, \lambda \in \mathbb{C}^*\} \simeq (\mathbb{C}^*)^2. \quad \diamond$$

Example 5.1.4. Let $\sigma = \text{Cone}(de_1 - e_2, e_2) \subseteq \mathbb{R}^2$, which gives the rational normal cone \hat{C}_d . Example 4.1.4 shows that $\text{Cl}(\hat{C}_d) \simeq \mathbb{Z}/d\mathbb{Z}$, so that

$$G = \text{Hom}_{\mathbb{Z}}(\mathbb{Z}/d\mathbb{Z}, \mathbb{C}^*) \simeq \mu_d,$$

where $\mu_d \subseteq \mathbb{C}^*$ is the group of d th roots of unity. To see how G acts on \mathbb{C}^2 , one uses the ray generators $u_1 = de_1 - e_2$ and $u_2 = e_2$ to compute that

$$G = \{(\zeta, \zeta) \mid \zeta^d = 1\} \simeq \mu_d$$

(Exercise 5.1.1). This shows that G can have torsion. \(\diamond\)

The Exceptional Set. For the quotient representation of X_Σ , we have the group G and the affine space $\mathbb{C}^{\Sigma(1)}$. All that is missing is the exceptional set $Z \subseteq \mathbb{C}^{\Sigma(1)}$ that we remove from $\mathbb{C}^{\Sigma(1)}$ before taking the quotient by G .

One useful observation is that G and $\mathbb{C}^{\Sigma(1)}$ depend only on $\Sigma(1)$. In order to get X_Σ , we need something that encodes the rest of the fan Σ . We will do this using a monomial ideal in the coordinate ring of $\mathbb{C}^{\Sigma(1)}$. Introduce a variable x_ρ for each $\rho \in \Sigma(1)$ and let

$$S = \mathbb{C}[x_\rho \mid \rho \in \Sigma(1)].$$

Then $\text{Spec}(S) = \mathbb{C}^{\Sigma(1)}$. We call S the *total coordinate ring* of X_Σ .

For each cone $\sigma \in \Sigma$, define the monomial

$$x^{\hat{\sigma}} = \prod_{\rho \notin \sigma(1)} x_\rho.$$

Thus $x^{\hat{\sigma}}$ is the product of the variables corresponding to rays not in σ . Then define the *irrelevant ideal*

$$B(\Sigma) = \langle x^{\hat{\sigma}} \mid \sigma \in \Sigma \rangle \subseteq S.$$

A useful observation is that $x^{\hat{\tau}}$ is a multiple of $x^{\hat{\sigma}}$ whenever $\tau \preceq \sigma$. Hence, if Σ_{\max} is the set of maximal cones of Σ , then

$$B(\Sigma) = \langle x^{\hat{\sigma}} \mid \sigma \in \Sigma_{\max} \rangle.$$

Furthermore, one sees easily that the minimal generators of $B(\Sigma)$ are precisely the $x^{\hat{\sigma}}$ for $\sigma \in \Sigma_{\max}$. Hence, once we have $\Sigma(1)$, $B(\Sigma)$ determines Σ uniquely.

Now define

$$Z(\Sigma) = \mathbf{V}(B(\Sigma)) \subseteq \mathbb{C}^{\Sigma(1)}.$$

The variety of a monomial ideal is a union of coordinate subspaces. For $B(\Sigma)$, the coordinate subspaces can be described in terms of *primitive collections*, which are defined as follows.

Definition 5.1.5. A subset $C \subseteq \Sigma(1)$ is a *primitive collection* if:

- (a) $C \not\subseteq \sigma(1)$ for all $\sigma \in \Sigma$.
- (b) For every proper subset $C' \subsetneq C$, there is $\sigma \in \Sigma$ with $C' \subseteq \sigma(1)$.

Proposition 5.1.6. The $Z(\Sigma)$ as a union of irreducible components is given by

$$Z(\Sigma) = \bigcup_C \mathbf{V}(x_\rho \mid \rho \in C),$$

where the union is over all primitive collections $C \subseteq \Sigma(1)$.

Proof. It suffices to determine the maximal coordinate subspaces contained in $Z(\Sigma)$. Suppose that $\mathbf{V}(x_{\rho_1}, \dots, x_{\rho_s}) \subseteq Z(\Sigma)$ is such a subspace and take $\sigma \in \Sigma$. Since $x^{\hat{\sigma}}$ vanishes on $Z(\Sigma)$ and $\langle x_{\rho_1}, \dots, x_{\rho_s} \rangle$ is prime, the Nullstellensatz implies $x^{\hat{\sigma}}$ is divisible by some x_{ρ_i} , i.e., $\rho_i \notin \sigma(1)$. It follows that $C = \{\rho_1, \dots, \rho_s\}$ satisfies condition (a) of Definition 5.1.5, and condition (b) follows easily from the maximality of $\mathbf{V}(x_{\rho_1}, \dots, x_{\rho_s})$. Hence C is a primitive collection.

Conversely, every primitive collection C gives a maximal coordinate subspace $\mathbf{V}(x_\rho \mid \rho \in C)$ contained in $Z(\Sigma)$, and the proposition follows. \square

In Exercise 5.1.2 you will show that the algebraic analog of Proposition 5.1.6 is the primary decomposition

$$B(\Sigma) = \bigcap_C \langle x_\rho \mid \rho \in C \rangle.$$

Here are some easy examples.

Example 5.1.7. The fan for \mathbb{P}^n consists of cones generated by proper subsets of $\{u_0, \dots, u_n\}$, where u_0, \dots, u_n are as in Example 5.1.2. Let u_i generate ρ_i , $0 \leq i \leq n$, and let x_i be the corresponding variable in the total coordinate ring. We compute $Z(\Sigma)$ in two ways:

- The maximal cones of the fan are given by $\sigma_i = \text{Cone}(u_0, \dots, \widehat{u_i}, \dots, u_n)$. Then $x^{\hat{\sigma}_i} = x_i$, so that $B(\Sigma) = \langle x_0, \dots, x_n \rangle$. Hence $Z(\Sigma) = \{0\}$.
- The only primitive collection is $\{\rho_0, \dots, \rho_n\}$, so $Z(\Sigma) = \mathbf{V}(x_0, \dots, x_n) = \{0\}$ by Proposition 5.1.6. \diamond

Example 5.1.8. The fan for $\mathbb{P}^1 \times \mathbb{P}^1$ has ray generators $u_1 = e_1, u_2 = -e_1, u_3 = e_2, u_4 = -e_2$. See Example 3.1.12 for a picture of this fan. Each u_i gives a ray ρ_i and a variable x_i . We compute $Z(\Sigma)$ in two ways:

- The maximal cone $\text{Cone}(u_1, u_3)$ gives the monomial x_2x_4 , and similarly the other maximal cones give the monomials x_1x_4, x_1x_3, x_2x_3 . Thus

$$B(\Sigma) = \langle x_2x_4, x_1x_4, x_1x_3, x_2x_3 \rangle,$$

and one checks that $Z(\Sigma) = \{0\} \times \mathbb{C}^2 \cup \mathbb{C}^2 \times \{0\}$.

- The only primitive collections are $\{\rho_1, \rho_2\}$ and $\{\rho_3, \rho_4\}$, so that

$$Z(\Sigma) = \mathbf{V}(x_1, x_2) \cup \mathbf{V}(x_3, x_4) = \{0\} \times \mathbb{C}^2 \cup \mathbb{C}^2 \times \{0\}$$

by Proposition 5.1.6. Note also that $B(\Sigma) = \langle x_1, x_2 \rangle \cap \langle x_3, x_4 \rangle$. \diamond

A final observation is that $(\mathbb{C}^*)^{\Sigma(1)}$ acts on $\mathbb{C}^{\Sigma(1)}$ by diagonal matrices and hence induces an action on $\mathbb{C}^{\Sigma(1)} \setminus Z(\Sigma)$. It follows that $G \subseteq (\mathbb{C}^*)^{\Sigma(1)}$ also acts on $\mathbb{C}^{\Sigma(1)} \setminus Z(\Sigma)$. We are now ready to take the quotient.

The Quotient Construction. To represent X_Σ as a quotient, we first construct a toric morphism $\mathbb{C}^{\Sigma(1)} \setminus Z(\Sigma) \rightarrow X_\Sigma$. Let $\{e_\rho \mid \rho \in \Sigma(1)\}$ be the standard basis of the lattice $\mathbb{Z}^{\Sigma(1)}$. For each $\sigma \in \Sigma$, define the cone

$$\tilde{\sigma} = \text{Cone}(e_\rho \mid \rho \in \sigma(1)) \subseteq \mathbb{R}^{\Sigma(1)}.$$

It is easy to see that these cones and their faces form a fan

$$\tilde{\Sigma} = \{\tau \mid \tau \preceq \tilde{\sigma} \text{ for some } \sigma \in \Sigma\}$$

in $(\mathbb{Z}^{\Sigma(1)})_{\mathbb{R}} = \mathbb{R}^{\Sigma(1)}$. This fan has the following nice properties.

Proposition 5.1.9. *Let $\tilde{\Sigma}$ be the fan defined above.*

- $\mathbb{C}^{\Sigma(1)} \setminus Z(\Sigma)$ is the toric variety of the fan $\tilde{\Sigma}$.
- The map $e_\rho \mapsto u_\rho$ defines a map of lattices $\mathbb{Z}^{\Sigma(1)} \rightarrow N$ that is compatible with the fans $\tilde{\Sigma}$ in $\mathbb{R}^{\Sigma(1)}$ and Σ in $N_{\mathbb{R}}$.
- The resulting toric morphism

$$\pi : \mathbb{C}^{\Sigma(1)} \setminus Z(\Sigma) \longrightarrow X_\Sigma$$

is constant on G -orbits.

Proof. For part (a), let $\tilde{\Sigma}_0$ be the fan consisting of $\text{Cone}(e_\rho \mid \rho \in \Sigma(1))$ and its faces. Note that $\tilde{\Sigma}$ is a subfan of $\tilde{\Sigma}_0$. Since $\tilde{\Sigma}_0$ is the fan of $\mathbb{C}^{\Sigma(1)}$, we get the toric variety of $\tilde{\Sigma}$ by taking $\mathbb{C}^{\Sigma(1)}$ and then removing the orbits corresponding to all cones in $\tilde{\Sigma}_0 \setminus \tilde{\Sigma}$. By the Orbit-Cone Correspondence (Theorem 3.2.6), this is equivalent to removing the orbit closures of the minimal elements of $\tilde{\Sigma}_0 \setminus \tilde{\Sigma}$. But these minimal elements are precisely the primitive collections $C \subseteq \Sigma(1)$. Since the corresponding orbit closure is $\mathbf{V}(x_\rho \mid \rho \in C)$, removing these orbit closures means removing

$$Z(\Sigma) = \bigcup_C \mathbf{V}(x_\rho \mid \rho \in C).$$

For part (b), define $\bar{\pi} : \mathbb{Z}^{\Sigma(1)} \rightarrow N$ by $\bar{\pi}(e_\rho) = u_\rho$. Since the minimal generators of $\sigma \in \Sigma$ are given by u_ρ , $\rho \in \sigma(1)$, we have $\bar{\pi}_{\mathbb{R}}(\tilde{\sigma}) = \sigma$ by the definition of $\tilde{\sigma}$. Hence $\bar{\pi}$ is compatible with respect to the fans $\tilde{\Sigma}$ and Σ .

The map of tori induced by $\bar{\pi}$ is the map $(\mathbb{C}^*)^{\Sigma(1)} \rightarrow T_N$ from the exact sequence (5.1.2) (you will check this in Exercise 5.1.3). Hence, if $g \in G \subseteq (\mathbb{C}^*)^{\Sigma(1)}$ and $x \in \mathbb{C}^{\Sigma(1)} \setminus Z(\Sigma)$, then

$$\pi(g \cdot x) = \pi(g) \cdot \pi(x) = \pi(x),$$

where the first equality holds by equivariance and the second holds since G is the kernel of $(\mathbb{C}^*)^{\Sigma(1)} \rightarrow T_N$. This proves part (c) of the proposition. \square

We can now give the quotient construction of X_Σ .

Theorem 5.1.10. *Let X_Σ be a toric variety without torus factors and consider the toric morphism $\pi : \mathbb{C}^{\Sigma(1)} \setminus Z(\Sigma) \rightarrow X_\Sigma$ from Proposition 5.1.9. Then:*

(a) *π is an almost geometric quotient for the action of G on $\mathbb{C}^{\Sigma(1)} \setminus Z(\Sigma)$, so that*

$$X_\Sigma \simeq (\mathbb{C}^{\Sigma(1)} \setminus Z(\Sigma)) // G.$$

(b) *π is a geometric quotient if and only if Σ is simplicial.*

Proof. We begin by studying the map

$$(5.1.3) \quad \pi|_{\pi^{-1}(U_\sigma)} : \pi^{-1}(U_\sigma) \longrightarrow U_\sigma$$

for $\sigma \in \Sigma$. First observe that if $\tau, \sigma \in \Sigma$, then $\bar{\pi}_{\mathbb{R}}(\tilde{\tau}) \subseteq \sigma$ is equivalent to $\tau \preceq \sigma$. It follows that $\pi^{-1}(U_\sigma)$ is the toric variety $U_{\tilde{\sigma}}$ of $\tilde{\sigma} = \text{Cone}(e_\rho \mid \rho \in \sigma(1))$. This shows that (5.1.3) is the toric morphism

$$\pi_\sigma : U_{\tilde{\sigma}} \longrightarrow U_\sigma,$$

where for simplicity we write π_σ instead of $\pi|_{\pi^{-1}(U_\sigma)}$.

Our first task is to show that π_σ is a good categorical quotient. Since G is reductive, Proposition 5.0.9 reduces this to showing that the map π_σ^* on coordinate rings induces an isomorphism

$$(5.1.4) \quad \mathbb{C}[U_\sigma] \simeq \mathbb{C}[U_{\tilde{\sigma}}]^G.$$

The map π_σ^* can be described as follows:

- For $U_{\tilde{\sigma}}$, the cone $\tilde{\sigma}$ gives the semigroup

$$\tilde{\sigma}^\vee \cap \mathbb{Z}^{\Sigma(1)} = \{(a_\rho) \in \mathbb{Z}^{\Sigma(1)} \mid a_\rho \geq 0 \text{ for all } \rho \in \sigma(1)\}.$$

Hence the coordinate ring of $U_{\tilde{\sigma}}$ is the semigroup algebra

$$\mathbb{C}[U_{\tilde{\sigma}}] = \mathbb{C}[\prod_\rho x_\rho^{a_\rho} \mid a_\rho \geq 0 \text{ for all } \rho \in \sigma(1)] = S_{x^{\tilde{\sigma}}},$$

where $S_{x^{\tilde{\sigma}}}$ is the localization $S = \mathbb{C}[x_\rho \mid \rho \in \Sigma(1)]$ at $x^{\tilde{\sigma}} = \prod_{\rho \notin \sigma(1)} x_\rho$.

- For U_σ , the coordinate ring is the usual semigroup algebra $\mathbb{C}[\sigma^\vee \cap M]$.

- The map $\bar{\pi} : \mathbb{Z}^{\Sigma(1)} \rightarrow N$ dualizes to the map $M \rightarrow \mathbb{Z}^{\Sigma(1)}$ sending $m \in M$ to $(\langle m, u_\rho \rangle) \in \mathbb{Z}^{\Sigma(1)}$. It follows that $\pi_\sigma^* : \mathbb{C}[\sigma^\vee \cap M] \rightarrow S_{x^{\hat{\sigma}}}$ is given by

$$\pi_\sigma^*(\chi^m) = \prod_\rho x_\rho^{\langle m, u_\rho \rangle}.$$

Note that $\langle m, u_\rho \rangle \geq 0$ for all $\rho \in \sigma(1)$, so that the expression on the right really lies in $S_{x^{\hat{\sigma}}}$.

Thus π_σ^* can be written $\pi_\sigma^* : \mathbb{C}[\sigma^\vee \cap M] \rightarrow S_{x^{\hat{\sigma}}}$, and since π_σ is constant on G -orbits, π_σ^* factors

$$\mathbb{C}[\sigma^\vee \cap M] \longrightarrow (S_{x^{\hat{\sigma}}})^G \subseteq S_{x^{\hat{\sigma}}}.$$

The map π_σ has Zariski dense image in U_σ since $\pi_\sigma((\mathbb{C}^*)^{\Sigma(1)}) = T_N$ by the exact sequence (5.1.2). It follows that π_σ^* is injective. To show that its image is $(S_{x^{\hat{\sigma}}})^G$, take $f \in S_{x^{\hat{\sigma}}}$ and write it as

$$f = \sum_a c_a x^a$$

where each $x^a = \prod_\rho x_\rho^{a_\rho}$ satisfies $a_\rho \geq 0$ for all $\rho \in \sigma(1)$. Then f is G -invariant if and only if for all $t = (t_\rho) \in G$, we have

$$\sum_a c_a x^a = \sum_a c_a t^a x^a.$$

Thus f is G -invariant if and only if $t^a = 1$ for all $t \in G$ whenever $c_a \neq 0$. The map $t \mapsto t^a$ is a character on G and hence is an element of its character group $\text{Cl}(X_\Sigma)$ (Lemma 5.1.1). This character is trivial when $c_a \neq 0$, so that by (5.1.1), the exponent vector $a = (a_\rho)$ must come from an element $m \in M$, i.e., $a_\rho = \langle m, u_\rho \rangle$ for all $\rho \in \Sigma(1)$. But $x^a \in S_{x^{\hat{\sigma}}}$, which implies that

$$\langle m, u_\rho \rangle = a_\rho \geq 0 \quad \text{for all } \rho \in \sigma(1).$$

Hence $m \in \sigma^\vee \cap M$, which implies that f is in the image of π_σ^* . This proves (5.1.4). We conclude that π_σ is a good categorical quotient.

We next prove that

$$(5.1.5) \quad \pi_\sigma : U_{\hat{\sigma}} \rightarrow U_\sigma \text{ is a geometric quotient} \iff \sigma \text{ is simplicial.}$$

First suppose that σ is simplicial. Then its ray generators u_ρ , $\rho \in \sigma(1)$, are linearly independent, and by hypothesis, the ray generators u_ρ , $\rho \in \Sigma(1)$, span $\mathbb{R}^{\Sigma(1)}$. Hence we can write $\Sigma(1)$ as a disjoint union

$$\Sigma(1) = \sigma(1) \cup A \cup B$$

such that the u_ρ for $\rho \in \sigma(1) \cup A$ form a basis of $\mathbb{R}^{\Sigma(1)}$. Projection onto the coordinates coming from $\sigma(1) \cup A$ gives an exact sequence

$$0 \longrightarrow \mathbb{Z}^B \longrightarrow \mathbb{Z}^{\Sigma(1)} \longrightarrow \mathbb{Z}^{\sigma(1) \cup A} \longrightarrow 0.$$

Note also that since the u_ρ , $\rho \in \sigma(1) \cup A$, form a basis, the map $M \rightarrow \mathbb{Z}^{\sigma(1) \cup A}$ given by $m \mapsto (\langle m, u_\rho \rangle)_{\rho \in \sigma(1) \cup A}$ gives an exact sequence

$$0 \longrightarrow M \longrightarrow \mathbb{Z}^{\sigma(1) \cup A} \longrightarrow Q \longrightarrow 0$$

where the cokernel Q is finite.

Combining the two above exact sequences with (5.1.1), we get a commutative diagram with exact rows and columns:

$$\begin{array}{ccccccc} & & & 0 & & 0 & \\ & & & \downarrow & & \downarrow & \\ & & & \mathbb{Z}^B & = & \mathbb{Z}^B & \\ & & & \downarrow & & \downarrow & \\ 0 & \rightarrow & M & \rightarrow & \mathbb{Z}^{\Sigma(1)} & \rightarrow & \text{Cl}(X_\Sigma) \rightarrow 0 \\ & & \parallel & & \downarrow & & \downarrow \\ 0 & \rightarrow & M & \rightarrow & \mathbb{Z}^{\sigma(1) \cup A} & \rightarrow & Q \rightarrow 0 \\ & & & & \downarrow & & \downarrow \\ & & & & 0 & & 0 \end{array}$$

Now let $H = \text{Hom}_{\mathbb{Z}}(Q, \mathbb{C}^*)$. Then applying $\text{Hom}_{\mathbb{Z}}(-, \mathbb{C}^*)$ to the column on the right gives the exact sequence

$$(5.1.6) \quad 1 \longrightarrow H \longrightarrow G \xrightarrow{\Phi} (\mathbb{C}^*)^B \longrightarrow 1$$

of affine algebraic groups. Note that H is finite since Q is.

We can write $U_{\tilde{\sigma}}$ as the product

$$U_{\tilde{\sigma}} = \underbrace{\mathbb{C}^{\sigma(1)} \times (\mathbb{C}^*)^A}_Y \times (\mathbb{C}^*)^B = Y \times (\mathbb{C}^*)^B,$$

and note that the G -action on the second factor of $U_{\tilde{\sigma}} = Y \times (\mathbb{C}^*)^B$ is given by the map Φ from (5.1.6). We regard Y as a subset of $U_{\tilde{\sigma}}$ via the map $y \in Y \mapsto (y, 1) \in Y \times (\mathbb{C}^*)^B$. Thus $H = \ker(\Phi)$ acts on Y . Hence we have a commutative diagram

$$(5.1.7) \quad \begin{array}{ccc} U_{\tilde{\sigma}} & \longrightarrow & U_\sigma \\ \uparrow & \nearrow & \\ Y & & \end{array}$$

We showed above that $C[U_\sigma] \simeq \mathbb{C}[U_{\tilde{\sigma}}]^G$, and $C[U_\sigma] \simeq \mathbb{C}[Y]^H$ follows by a similar argument (Exercise 5.1.4). But H is finite, so that the H -orbits are closed. Hence $Y \rightarrow U_\sigma$ is a geometric quotient by Proposition 5.0.8.

Now consider two distinct G -orbits in $U_{\tilde{\sigma}}$. Using the action of $(\mathbb{C}^*)^B$ and (5.1.6), we can assume that the orbits are $G \cdot y, G \cdot y'$ for $y, y' \in Y$. These orbits contain $H \cdot y, H \cdot y'$, which are also distinct. Since $Y \rightarrow U_\sigma$ is a geometric quotient,

these H -orbits map to distinct points in U_σ , and then the same is true for the G -orbits by the commutativity of (5.1.7). By Proposition 5.0.8, it follows that π_σ is a geometric quotient when Σ is simplicial.

To prove the other implication of (5.1.5), suppose that $\sigma \in \Sigma$ is non-simplicial. We construct a non-closed orbit in $U_{\tilde{\sigma}}$ as follows. Since σ is non-simplicial, there is a relation $\sum_{\rho \in \sigma(1)} a_\rho u_\rho = 0$ where $a_\rho \in \mathbb{Z}$ and $a_\rho > 0$ for at least one ρ . If we set $a_\rho = 0$ for $\rho \notin \sigma(1)$, then the one-parameter subgroup

$$\lambda^a(t) = (t^{a_\rho}) \in (\mathbb{C}^*)^{\Sigma(1)}$$

is actually a one-parameter subgroup of G . This follows easily from Lemma 5.1.1 and $\sum_\rho a_\rho u_\rho = 0$ (Exercise 5.1.4).

The affine open subset $U_{\tilde{\sigma}} \subseteq \mathbb{C}^{\Sigma(1)}$ consists of all points whose ρ th coordinate is nonzero for all $\rho \notin \sigma(1)$. Hence the point $u = (u_\rho)$, where

$$u_\rho = \begin{cases} 1 & a_\rho \geq 0 \\ 0 & a_\rho < 0, \end{cases}$$

lies in $U_{\tilde{\sigma}}$. Now consider $\lim_{t \rightarrow 0} \lambda^a(t) \cdot u$. The limit exists in $\mathbb{C}^{\Sigma(1)}$ since $u_\rho = 0$ whenever $a_\rho < 0$. Furthermore, if $\rho \notin \sigma(1)$, the ρ th coordinate $\lambda^a(t) \cdot u$ is 1 for all t , so that the limit $u_0 = \lim_{t \rightarrow 0} \lambda^a(t) \cdot u$ lies in $U_{\tilde{\sigma}}$. By assumption, there is $\rho_0 \in \sigma(1)$ with $a_{\rho_0} > 0$. This has the following consequences:

- Since the ρ_0 th coordinate of u is nonzero, the same is true for every element in its G -orbit $G \cdot u$.
- Since $a_{\rho_0} > 0$, the ρ_0 th coordinate of $u_0 = \lim_{t \rightarrow 0} \lambda^a(t) \cdot u$ is zero.

Then $G \cdot u$ is not closed in $U_{\tilde{\sigma}}$ since its Zariski closure contains $u_0 \in U_{\tilde{\sigma}} \setminus G \cdot u$. This shows that π_σ is not a geometric quotient and completes the proof of (5.1.5).

We can now prove the theorem. Since the maps (5.1.3) are good categorical quotients, the same is true for $\pi : \mathbb{C}^{\Sigma(1)} \setminus Z(\Sigma) \rightarrow X_\Sigma$ by Proposition 5.0.12. To prove part (a), let $\Sigma' \subseteq \Sigma$ be the subfan of simplicial cones of Σ and set

$$U = \bigcup_{\sigma \in \Sigma'} U_\sigma, \quad U_0 = \pi^{-1}(U) = \bigcup_{\sigma \in \Sigma'} U_{\tilde{\sigma}}.$$

As above, $\pi|_{U_0} : U_0 \rightarrow U$ is a good categorical quotient, and by (5.1.5), π_σ is a geometric quotient for each $\sigma \in \Sigma'$. It follows easily $\pi|_{U_0}$ is a geometric quotient, so that π satisfies the second condition of Proposition 5.0.11. Thus π is an almost geometric quotient. This argument also shows that π is a geometric quotient when Σ is simplicial, which proves half of part (b). The other half follows from (5.1.5), and then the proof of the theorem is complete. \square

One nice feature of the quotient $X_\Sigma = (\mathbb{C}^{\Sigma(1)} \setminus Z(\Sigma)) // G$ is that it is compatible with the tori, meaning that we have a commutative diagram

$$\begin{array}{ccc} X_\Sigma & \simeq & (\mathbb{C}^{\Sigma(1)} \setminus Z(\Sigma)) // G \\ \uparrow & & \uparrow \\ T_N & \simeq & (\mathbb{C}^*)^{\Sigma(1)} / G \end{array}$$

where the isomorphism on the bottom comes from (5.1.2) and the vertical arrows are inclusions.

Examples. Here are some examples of the quotient construction.

Example 5.1.11. By Examples 5.1.2 and 5.1.7, \mathbb{P}^n has quotient representation

$$\mathbb{P}^n = (\mathbb{C}^{n+1} \setminus \{0\}) / \mathbb{C}^*,$$

where \mathbb{C}^* acts by scalar multiplication. This is a geometric quotient since Σ is smooth and hence simplicial. \diamond

Example 5.1.12. By Examples 5.1.3 and 5.1.8, $\mathbb{P}^1 \times \mathbb{P}^1$ has quotient representation

$$\mathbb{P}^1 \times \mathbb{P}^1 = (\mathbb{C}^4 \setminus (\{0\} \times \mathbb{C}^2 \cup \mathbb{C}^2 \times \{0\})) / (\mathbb{C}^*)^2,$$

where $(\mathbb{C}^*)^2$ acts via $(\mu, \lambda) \cdot (a, b, c, d) = (\mu a, \mu b, \lambda c, \lambda d)$. This is again a geometric quotient. \diamond

Example 5.1.13. Fix positive integers q_0, \dots, q_n with $\gcd(q_0, \dots, q_n) = 1$ and let N be the lattice $\mathbb{Z}^{n+1} / \mathbb{Z}(q_0, \dots, q_n)$. The images of the standard basis in \mathbb{Z}^{n+1} give primitive elements $u_0, \dots, u_n \in N$ satisfying $q_0 u_0 + \dots + q_n u_n = 0$. Let Σ be the fan consisting of all cones generated by proper subsets of $\{u_0, \dots, u_n\}$.

As in Example 3.1.17, the corresponding toric variety is denoted $\mathbb{P}(q_0, \dots, q_n)$. Using the quotient construction, we can now explain why this is called a weighted projective space.

We have $\mathbb{C}^{\Sigma(1)} = \mathbb{C}^{n+1}$ since Σ has $n+1$ rays, and $Z(\Sigma) = \{0\}$ by the argument used in Example 5.1.7. It remains to compute $G \subseteq (\mathbb{C}^*)^{n+1}$. In Exercise 4.1.5, you showed that the maps $m \in M \mapsto (\langle m, u_0 \rangle, \dots, \langle m, u_n \rangle) \in \mathbb{Z}^{n+1}$ and $(a_0, \dots, a_n) \in \mathbb{Z}^{n+1} \mapsto a_0 q_0 + \dots + a_n q_n \in \mathbb{Z}$ give the short exact sequence

$$(5.1.8) \quad 0 \longrightarrow M \longrightarrow \mathbb{Z}^{n+1} \longrightarrow \mathbb{Z} \longrightarrow 0.$$

This shows that the class group is \mathbb{Z} . Note also that $e_i \in \mathbb{Z}^{n+1}$ maps to $q_i \in \mathbb{Z}$. In Exercise 5.1.5 you will compute that

$$G = \{(t^{q_0}, \dots, t^{q_n}) \mid t \in \mathbb{C}^*\} \simeq \mathbb{C}^*.$$

This is the action of \mathbb{C}^* on \mathbb{C}^{n+1} given by

$$t \cdot (u_0, \dots, u_n) = (t^{q_0} u_0, \dots, t^{q_n} u_n).$$

Since Σ is simplicial (every proper subset of $\{u_0, \dots, u_n\}$ is linearly independent in $N_{\mathbb{R}}$), we get the geometric quotient

$$\mathbb{P}(q_0, \dots, q_n) = (\mathbb{C}^{n+1} \setminus \{0\})/\mathbb{C}^*.$$

This gives the set-theoretic definition of $\mathbb{P}(q_0, \dots, q_n)$ from §2.0 and also gives its structure as a variety since we have a geometric quotient. \diamond

Example 5.1.14. Consider the cone $\sigma = \text{Cone}(e_1, e_2, e_1 + e_3, e_2 + e_3) \subseteq \mathbb{R}^3$. To find the quotient representation of U_σ , we label the ray generators as

$$u_1 = e_1, u_2 = e_2 + e_3, u_3 = e_2, u_4 = e_1 + e_3.$$

Then $\mathbb{C}^{\Sigma(1)} = \mathbb{C}^4$ and $Z(\Sigma) = \emptyset$ since $x^{\hat{\sigma}} = 1$. To determine the group $G \subseteq (\mathbb{C}^*)^4$, note that the exact sequence (5.1.1) becomes

$$0 \longrightarrow \mathbb{Z}^3 \longrightarrow \mathbb{Z}^4 \longrightarrow \mathbb{Z} \longrightarrow 0,$$

where $(a_1, a_2, a_3, a_4) \in \mathbb{Z}^4 \mapsto a_1 + a_2 - a_3 - a_4 \in \mathbb{Z}$. This makes it straightforward to show that

$$G = \{(\lambda, \lambda, \lambda^{-1}, \lambda^{-1}) \mid \lambda \in \mathbb{C}^*\} \simeq \mathbb{C}^*.$$

Hence we get the quotient presentation

$$U_\sigma = \mathbb{C}^4 // \mathbb{C}^*.$$

In Example 5.0.2, we gave a naive argument that the quotient was $\mathbb{V}(xy - zw)$. We now see that the intrinsic meaning of Example 5.0.2 is the quotient construction of U_σ given by Theorem 5.1.10. This example is not a geometric quotient since σ is not simplicial. \diamond

Example 5.1.15. Let $\text{Bl}_0(\mathbb{C}^2)$ be the blowup of \mathbb{C}^2 at the origin, whose fan Σ is shown in Figure 1 on the next page. By Example 4.1.5, $\text{Cl}(\text{Bl}_0(\mathbb{C}^2)) \simeq \mathbb{Z}$ with

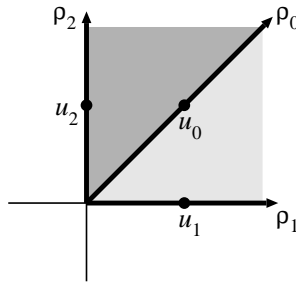

Figure 1. The fan Σ for the blowup of \mathbb{C}^2 at the origin

generator $[D_1] = [D_2] = -[D_0]$. Hence $G = \mathbb{C}^*$ and the irrelevant ideal is $B(\Sigma) = \langle x, y \rangle$. This gives the geometric quotient

$$\text{Bl}_0(\mathbb{C}^2) \simeq (\mathbb{C}^3 \setminus (\mathbb{C} \times \{0, 0\})) / \mathbb{C}^*,$$

where the \mathbb{C}^* -action is given by $\lambda \cdot (t, x, y) = (\lambda^{-1}t, \lambda x, \lambda y)$.

We also have $\mathbb{C}[t, x, y]^{\mathbb{C}^*} = \mathbb{C}[tx, ty]$. Then the inclusion

$$\mathbb{C}^3 \setminus (\mathbb{C} \times \{0, 0\}) \subseteq \mathbb{C}^3$$

induces the map on quotients

$$\phi : \text{Bl}_0(\mathbb{C}^2) \simeq (\mathbb{C}^3 \setminus (\mathbb{C} \times \{0, 0\})) / \mathbb{C}^* \longrightarrow \mathbb{C}^3 // \mathbb{C}^* \simeq \mathbb{C}^2,$$

where the final isomorphism uses

$$\mathbb{C}^3 // \mathbb{C}^* = \text{Spec}(\mathbb{C}[t, x, y]^{\mathbb{C}^*}) = \text{Spec}(\mathbb{C}[tx, ty]).$$

In terms of homogeneous coordinates, $\phi(t, x, y) = (tx, ty)$. This map is the toric morphism $\text{Bl}_0(\mathbb{C}^2) \rightarrow \mathbb{C}^2$ induced by the refinement of $\text{Cone}(u_1, u_2)$ given by Σ .

The quotient representation makes it easy to see why $\text{Bl}_0(\mathbb{C}^2)$ is the blowup of \mathbb{C}^2 at the origin. Given a point of $\text{Bl}_0(\mathbb{C}^2)$ with homogeneous coordinates (t, x, y) , there are two possibilities:

- $t \neq 0$, in which case $t \cdot (t, x, y) = (1, tx, ty)$. This maps to $(tx, ty) \in \mathbb{C}^2$ and is nonzero since x, y cannot both be zero. It follows that the part of $\text{Bl}_0(\mathbb{C}^2)$ where $t \neq 0$ looks like $\mathbb{C}^2 \setminus \{0, 0\}$.
- $t = 0$, in which case $(0, x, y)$ maps to the origin in \mathbb{C}^2 . Since $\lambda \cdot (0, x, y) = (\lambda x, \lambda y)$ and x, y cannot both be zero, it follows that the part of $\text{Bl}_0(\mathbb{C}^2)$ where $t = 0$ looks like \mathbb{P}^1 .

This shows that $\text{Bl}_0(\mathbb{C}^2)$ is built from \mathbb{C}^2 by replacing the origin with a copy of \mathbb{P}^1 , which is called the *exceptional locus* E . Since $E = \phi^{-1}(0, 0)$, we see that $\phi : X_\Sigma \rightarrow \mathbb{C}^2$ induces an isomorphism

$$\text{Bl}_0(\mathbb{C}^2) \setminus E \simeq \mathbb{C}^2 \setminus \{(0, 0)\}.$$

Note also that E is the divisor D_0 corresponding to the ray ρ_0 . You should be able to look at Figure 1 and see instantly that $D_0 \simeq \mathbb{P}^1$.

We can also check that lines through the origin behave properly. Consider the line L defined by $ax + by = 0$, where $(a, b) \neq (0, 0)$. When we pull this back to $\text{Bl}_0(\mathbb{C}^2)$, we get the subvariety defined by

$$a(tx) + b(ty) = 0.$$

This is the *total transform* of L . It factors as $t(ax + by) = 0$. Note that $t = 0$ defines the exceptional locus, so that once we remove this, we get the curve in $\text{Bl}_0(\mathbb{C}^2)$ defined by $ax + by = 0$. This is the *proper transform* of L , which meets the exceptional locus E at the point with homogeneous coordinates $(0, -b, a)$, corresponding to $(-b, a) \in \mathbb{P}^1$. In this way, we see how blowing up separates tangent directions through the origin. \diamond

The General Case. So far, we have assumed that X_Σ has no torus factors. When torus factors are present, X_Σ still has a quotient construction, though it is no longer canonical.

Let X_Σ be a toric variety with a torus factor. By Proposition 3.3.9, the ray generators u_ρ , $\rho \in \Sigma(1)$, span a proper subspace of $N_\mathbb{R}$. Let N' be the intersection of this subspace with N , and pick a complement N'' so that $N = N' \oplus N''$. The cones of Σ all lie in $N'_\mathbb{R}$ and hence give a fan Σ' in $N'_\mathbb{R}$. As in the proof of Proposition 3.3.9, we obtain

$$X_\Sigma \simeq X_{\Sigma', N'} \times (\mathbb{C}^*)^r$$

where $N'' \simeq \mathbb{Z}^r$. Theorem 5.1.10 applies to $X_{\Sigma', N'}$ since u_ρ , $\rho \in \Sigma'(1) = \Sigma(1)$, span $N'_\mathbb{R}$ by construction. Note also that $B(\Sigma') = B(\Sigma)$ and $Z(\Sigma') = Z(\Sigma)$. Hence

$$X_{\Sigma', N'} \simeq (\mathbb{C}^{\Sigma(1)} \setminus Z(\Sigma)) // G.$$

It follows that

$$\begin{aligned} X_\Sigma &\simeq X_{\Sigma', N'} \times (\mathbb{C}^*)^r \\ (5.1.9) \quad &\simeq (\mathbb{C}^{\Sigma(1)} \setminus Z(\Sigma)) // G \times (\mathbb{C}^*)^r \\ &\simeq (\mathbb{C}^{\Sigma(1)} \times (\mathbb{C}^*)^r \setminus Z(\Sigma) \times (\mathbb{C}^*)^r) // G, \end{aligned}$$

In the last line, we use the trivial action of G on $(\mathbb{C}^*)^r$. You will verify the last isomorphism in Exercise 5.1.6.

We can rewrite (5.1.9) as follows. Using $(\mathbb{C}^*)^r = \mathbb{C}^r \setminus \mathbf{V}(x_1 \cdots x_r)$, we obtain

$$\mathbb{C}^{\Sigma(1)} \times (\mathbb{C}^*)^r \setminus Z(\Sigma) \times (\mathbb{C}^*)^r = \mathbb{C}^{\Sigma(1)+r} \setminus Z'(\Sigma),$$

where $\mathbb{C}^{\Sigma(1)+r} = \mathbb{C}^{\Sigma(1)} \times \mathbb{C}^r$ and $Z'(\Sigma) = Z(\Sigma) \times \mathbb{C}^r \cup \mathbb{C}^{\Sigma(1)} \times \mathbf{V}(x_1 \cdots x_r)$. Hence the quotient presentation of X_Σ is the almost geometric quotient

$$(5.1.10) \quad X_\Sigma \simeq (\mathbb{C}^{\Sigma(1)+r} \setminus Z'(\Sigma)) // G.$$

This differs from Theorem 5.1.10 in two ways:

- The representation (5.1.10) is non-canonical since it depends on the choice of the complement N'' .
- $Z'(\Sigma)$ contains $\mathbf{V}(x_1 \cdots x_r) \times \mathbb{C}^{\Sigma(1)}$ and hence has codimension 1 in $\mathbb{C}^{\Sigma(1)+r}$. In contrast, $Z(\Sigma)$ always has codimension ≥ 2 in $\mathbb{C}^{\Sigma(1)}$ (this follows from Proposition 5.1.6 since every primitive collection has at least two elements).

In practice, (5.1.10) is rarely used, while Theorem 5.1.10 is a common tool in toric geometry.

Exercises for §5.1.

5.1.1. In Example 5.1.4, verify carefully that $G = \{(\zeta, \zeta) \mid \zeta \in \mu_d\}$.

5.1.2. Prove that $B(\Sigma) = \bigcap_C \langle x_\rho \mid \rho \in C \rangle$, where the intersection ranges over all primitive collections $C \subseteq \Sigma(1)$.

5.1.3. In Proposition 5.1.9, we defined $\bar{\pi} : \mathbb{Z}^{\Sigma(1)} \rightarrow N$, and in the proof we use the map of tori $(\mathbb{C}^*)^{\Sigma(1)} \rightarrow T_N$ induced by $\bar{\pi}$. Show that this is the map appearing in (5.1.2).

5.1.4. This exercise is concerned with the proof of Theorem 5.1.10.

- (a) Prove that the map $Y \rightarrow U_\sigma$ in (5.1.7) induces an isomorphism $\mathbb{C}[U_\sigma] \simeq \mathbb{C}[Y]^H$.
 (b) Prove that $\lambda^a(t) = (t^{a_\rho}) \in G$ when $\sum_\rho a_\rho u_\rho = 0$. Hint: Use Lemma 5.1.1. You can give a more conceptual proof by taking the dual of (5.1.1).

5.1.5. Show that the group G in Example 5.1.13 is given by $G = \{(t^{q_0}, \dots, t^{q_n}) \mid t \in \mathbb{C}^*\}$. Hint: Pick integers b_i such that $\sum_{i=0}^n b_i q_i = 1$. Given $(t_0, \dots, t_n) \in G$, set $t = \prod_{i=0}^n t_i^{b_i}$. Also note that if e_0, \dots, e_n is the standard basis of \mathbb{Z}^{n+1} , then $q_i e_j - q_j e_i \in \mathbb{Z}^{n+1}$ maps to $0 \in \mathbb{Z}$ in (5.1.8).

5.1.6. Let X be a variety with trivial G action. Prove that $(X \times U_{\bar{\sigma}}) // G \simeq X \times U_\sigma$ and use this to verify the final line of (5.1.9).

5.1.7. Consider the usual fan Σ for \mathbb{P}^2 with the lattice $N = \{(a, b) \in \mathbb{Z}^2 \mid a + b \equiv 0 \pmod{d}\}$, where d is a positive integer.

- (a) Prove that the ray generators are $u_1 = (d, 0)$, $u_2 = (0, d)$ and

$$u_0 = \begin{cases} (-d, -d) & d \text{ odd} \\ (-d/2, -d/2) & d \text{ even.} \end{cases}$$

- (b) Prove that the dual lattice is $M = \{(a/d, b/d) \mid a, b \in \mathbb{Z}, a - b \equiv 0 \pmod{d}\}$.
 (c) Prove that $\text{Cl}(X_\Sigma) = \mathbb{Z} \oplus \mathbb{Z}/d\mathbb{Z}$ (d odd) or $\mathbb{Z} \oplus \mathbb{Z}/\frac{d}{2}\mathbb{Z}$ (d even).
 (d) Compute the quotient representation of X_Σ .

5.1.8. Find the quotient representation of the Hirzebruch surface \mathcal{H}_r in Example 3.1.16.

5.1.9. Prove that G acts freely on $\mathbb{C}^{\Sigma(1)} \setminus Z(\Sigma)$ when the fan Σ is smooth. Hint: Let $\sigma \in \Sigma$ and suppose that $g = (t_\rho) \in G$ fixes $u = (u_\rho) \in U_{\bar{\sigma}}$. Show that $t_\rho = 1$ for $\rho \notin \sigma$ and then use Lemma 5.1.1 to show that $t_\rho = 1$ for all ρ .

5.1.10. Prove that G acts with finite isotropy subgroups on $\mathbb{C}^{\Sigma(1)} \setminus Z(\Sigma)$ when the fan Σ is simplicial. Hint: Use the proof of Theorem 5.1.10.

5.1.11. Prove that $2 \leq \text{codim}(Z(\Sigma)) \leq |\Sigma(1)|$. When Σ is a complete simplicial fan, a stronger result states that either

- (a) $2 \leq \text{codim}(Z(\Sigma)) \leq \lfloor \frac{1}{2} \dim X_\Sigma \rfloor + 1$, or
 (b) $|\Sigma(1)| = \dim X_\Sigma + 1$ and $Z(\Sigma) = \{0\}$.

This is proved in [9, Prop. 2.8]. See the next exercise for more on part (b).

5.1.12. Let Σ be a complete fan such that $|\Sigma(1)| = n + 1$, where $n = \dim X_\Sigma$. Prove that there is a weighted projective space $\mathbb{P}(q_0, \dots, q_n)$ and a finite group H acting on $\mathbb{P}(q_0, \dots, q_n)$ such that

$$X_\Sigma \simeq \mathbb{P}(q_0, \dots, q_n)/H.$$

Also prove that the following are equivalent:

- (a) X_Σ is a weighted projective space.
 (b) $\text{Cl}(X_\Sigma) \simeq \mathbb{Z}$.
 (c) N is generated by u_ρ , $\rho \in \Sigma(1)$.

Hint: Label the ray generators u_0, \dots, u_n . First show that Σ is simplicial and that there are positive integers q_0, \dots, q_n satisfying $\sum_{i=0}^n q_i u_i = 0$ and $\gcd(q_0, \dots, q_n) = 1$. Then consider the sublattice of N generated by the u_i and use Example 5.1.13. You will also need Proposition 3.3.7. If you get stuck, see [9, Lem. 2.11].

5.1.13. In the proof of Theorem 5.1.10, we showed that a non-simplicial cone leads to a non-closed G -orbit. Show that the non-closed G -orbit exhibited in Example 5.0.2 is an example of this construction. See also Example 5.1.14.

5.1.14. The proof of Theorem 5.1.10 used the fan Σ' consisting of the simplicial cones of Σ . Show that the quotient construction of $X_{\Sigma'}$ is the map $\pi|_{U_0} : U_0 \rightarrow U$ used in the proof of the theorem.

5.1.15. Example 5.1.15 gave the quotient construction of the blowup of $0 \in \mathbb{C}^2$ and used the quotient construction to describe the properties of the blowup. Give a similar treatment for the blowup of $\mathbb{C}^r \subseteq \mathbb{C}^n$ using the star subdivision described in §3.3.

§5.2. The Total Coordinate Ring

In this section we assume that X_Σ is a toric variety without torus factors. Its *total coordinate ring*

$$S = \mathbb{C}[x_\rho \mid \rho \in \Sigma(1)]$$

was defined in §5.1. This ring gives $\mathbb{C}^{\Sigma(1)} = \text{Spec}(S)$ and contains the irrelevant ideal

$$B(\Sigma) = \langle x^{\hat{\sigma}} \mid \sigma \in \Sigma \rangle$$

used in the quotient construction of X_Σ . In this section we will explore how this ring relates to the algebra and geometry of X_Σ .

The Grading. An important feature of the total coordinate ring S is its grading by the class group $\text{Cl}(X_\Sigma)$. We have the exact sequence (5.1.1)

$$0 \longrightarrow M \longrightarrow \mathbb{Z}^{\Sigma(1)} \longrightarrow \text{Cl}(X_\Sigma) \longrightarrow 0,$$

where $a = (a_\rho) \in \mathbb{Z}^{\Sigma(1)}$ maps to the divisor class $[\sum_\rho a_\rho D_\rho] \in \text{Cl}(X_\Sigma)$. Given a monomial $x^a = \prod_\rho x_\rho^{a_\rho} \in S$, define its degree to be

$$\deg(x^a) = [\sum_\rho a_\rho D_\rho] \in \text{Cl}(X_\Sigma).$$

For $\beta \in \text{Cl}(X_\Sigma)$, we let S_β denote the corresponding graded piece of S .

The grading on S is closely related to the group $G = \text{Hom}_{\mathbb{Z}}(\text{Cl}(X_\Sigma), \mathbb{C}^*)$. Recall that $\text{Cl}(X_\Sigma)$ is the character group of G , where as usual $\beta \in \text{Cl}(X_\Sigma)$ gives the character $\chi^\beta : G \rightarrow \mathbb{C}^*$. The action of G on $\mathbb{C}^{\Sigma(1)}$ induces an action on S with the property that given $f \in S$, we have

$$(5.2.1) \quad \begin{aligned} f \in S_\beta &\iff g \cdot f = \chi^\beta(g^{-1}) f \text{ for all } g \in G \\ &\iff f(g \cdot x) = \chi^\beta(g) f(x) \text{ for all } g \in G, x \in \mathbb{C}^{\Sigma(1)} \end{aligned}$$

(Exercise 5.2.1). Thus the graded pieces of S are the eigenspaces of the action of G on S . We say that $f \in S_\beta$ is *homogeneous* of degree β .

Example 5.2.1. The total coordinate ring of \mathbb{P}^n is $\mathbb{C}[x_0, \dots, x_n]$. By Example 4.1.6, the map $\mathbb{Z}^{n+1} \rightarrow \mathbb{Z} = \text{Cl}(\mathbb{P}^n)$ is $(a_0, \dots, a_n) \mapsto a_0 + \dots + a_n$. This gives the grading on $\mathbb{C}[x_0, \dots, x_n]$ where each variable x_i has degree 1, so that “homogeneous polynomial” has the usual meaning.

In Exercise 5.2.2 you will generalize this by showing that the total coordinate ring of the weighted projective space $\mathbb{P}(q_0, \dots, q_n)$ is $\mathbb{C}[x_0, \dots, x_n]$, where the variable x_i now has degree q_i . Here, “homogeneous polynomial” means weighted homogeneous polynomial. \diamond

Example 5.2.2. The fan for $\mathbb{P}^n \times \mathbb{P}^m$ is the product of the fans of \mathbb{P}^n and \mathbb{P}^m , and by Example 4.1.7, the class group is

$$\text{Cl}(\mathbb{P}^n \times \mathbb{P}^m) \simeq \text{Cl}(\mathbb{P}^n) \times \text{Cl}(\mathbb{P}^m) \simeq \mathbb{Z}^2.$$

The total coordinate ring is $\mathbb{C}[x_0, \dots, x_n, y_0, \dots, y_m]$, where

$$\deg(x_i) = (1, 0) \quad \deg(y_i) = (0, 1)$$

(Exercise 5.2.3). For this ring, “homogeneous polynomial” means bihomogeneous polynomial. \diamond

Example 5.2.3. Example 5.1.15 gave the quotient representation of the blowup $\text{Bl}_0(\mathbb{C}^2)$ of \mathbb{C}^2 at the origin. The fan Σ of $\text{Bl}_0(\mathbb{C}^2)$ is shown in Example 5.1.15 and has ray generators u_0, u_1, u_2 , corresponding to variables t, x, y in the total coordinate ring $S = \mathbb{C}[t, x, y]$. Since $\text{Cl}(\text{Bl}_0(\mathbb{C}^2)) \simeq \mathbb{Z}$, one can check that the grading on S is given by

$$\deg(t) = -1 \quad \text{and} \quad \deg(x) = \deg(y) = 1$$

(Exercise 5.2.4). Thus total coordinate rings can have some elements of positive degree and other elements of negative degree. \diamond

The Toric Ideal-Variety Correspondence. For n -dimensional projective space \mathbb{P}^n , a homogeneous ideal $I \subseteq \mathbb{C}[x_0, \dots, x_n]$ defines a projective variety $\mathbf{V}(I) \subseteq \mathbb{P}^n$. This generalizes to more general toric varieties X_Σ as follows.

We first assume that Σ is simplicial, so that we have a geometric quotient

$$\pi : \mathbb{C}^{\Sigma(1)} \setminus Z(\Sigma) \longrightarrow X_\Sigma$$

by Theorem 5.1.10. Given $p \in X_\Sigma$, we say a point $x \in \pi^{-1}(p)$ gives *homogeneous coordinates* for p . Since π is a geometric quotient, we have $\pi^{-1}(p) = G \cdot x$. Thus *all* homogeneous coordinates for p are of the form $g \cdot x$ for some $g \in G$.

Now let S be the total coordinate ring of X_Σ and let $f \in S$ be homogeneous for the $\text{Cl}(X_\Sigma)$ -grading on S , say $f \in S_\beta$. Then

$$f(g \cdot x) = \chi^\beta(g) f(x)$$

by (5.2.1), so that $f(x) = 0$ for *one* choice of homogeneous coordinates of $p \in X_\Sigma$ if and only if $f(x) = 0$ for *all* homogeneous coordinates of p . It follows that the

equation $f = 0$ is well-defined in X_Σ . We can use this to define subvarieties of X_Σ as follows.

Proposition 5.2.4. *Let S be the total coordinate ring of the simplicial toric variety X_Σ . Then:*

(a) *If $I \subseteq S$ is a homogeneous ideal, then*

$$\mathbf{V}(I) = \{\pi(x) \in X_\Sigma \mid f(x) = 0 \text{ for all } f \in I\}$$

is a closed subvariety of X_Σ .

(b) *All closed subvarieties of X_Σ arise this way.*

Proof. Given $I \subseteq S$ as in part (a), notice that

$$W = \{x \in \mathbb{C}^{\Sigma(1)} \setminus Z(\Sigma) \mid f(x) = 0 \text{ for all } f \in I\}$$

is a closed G -invariant subset of $\mathbb{C}^{\Sigma(1)} \setminus Z(\Sigma)$. By part (b) of the definition of good categorical quotient (Definition 5.0.5), $\mathbf{V}(I) = \pi(W)$ is closed in X_Σ .

Conversely, given a closed subset $Y \subseteq X_\Sigma$, its inverse image

$$\pi^{-1}(Y) \subseteq \mathbb{C}^{\Sigma(1)} \setminus Z(\Sigma)$$

is closed and G -invariant. Then the same is true for the Zariski closure

$$\overline{\pi^{-1}(Y)} \subseteq \mathbb{C}^{\Sigma(1)}.$$

It follows without difficulty that $I = \mathbf{I}(\overline{\pi^{-1}(Y)}) \subseteq S$ is a homogeneous ideal satisfying $\mathbf{V}(I) = Y$. \square

Example 5.2.5. The equation $x_\rho = 0$ defines the T_N -invariant closed subvariety $\mathbf{V}(x_\rho) \subseteq X_\Sigma$ which is easily seen to be the prime divisor D_ρ . This shows that D_ρ always has a global equation, though it fails to have local equations when D_ρ is not Cartier (see Example 4.2.3). \diamond

Classically, the Weak Nullstellensatz gives a necessary and sufficient condition for the variety of an ideal to be empty. This applies to \mathbb{C}^n and \mathbb{P}^n as follows:

- For \mathbb{C}^n : Given an ideal $I \subseteq \mathbb{C}[x_1, \dots, x_n]$,

$$\mathbf{V}(I) = \emptyset \text{ in } \mathbb{C}^n \iff 1 \in I.$$

- For \mathbb{P}^n : Given a homogeneous ideal $I \subseteq \mathbb{C}[x_0, \dots, x_n]$,

$$\mathbf{V}(I) = \emptyset \text{ in } \mathbb{P}^n \iff \langle x_0, \dots, x_n \rangle^\ell \subseteq I \text{ for some } \ell \geq 0.$$

For a toric version of the weak Nullstellensatz, we use the irrelevant ideal $B(\Sigma) = \langle x^\sigma \mid \sigma \in \Sigma \rangle \subseteq S$.

Proposition 5.2.6 (The Toric Weak Nullstellensatz). *Let X_Σ be a simplicial toric variety with total coordinate ring S and irrelevant ideal $B(\Sigma) \subseteq S$. If $I \subseteq S$ is a homogeneous ideal, then*

$$\mathbf{V}(I) = \emptyset \text{ in } X_\Sigma \iff B(\Sigma)^\ell \subseteq I \text{ for some } \ell \geq 0.$$

Proof. Let $\mathbf{V}_a(I) \subseteq \mathbb{C}^{\Sigma(1)}$ denote the affine variety defined by $I \subseteq S$. Then:

$$\begin{aligned} \mathbf{V}(I) = \emptyset \text{ in } X_\Sigma &\iff \mathbf{V}_a(I) \cap (\mathbb{C}^{\Sigma(1)} \setminus Z(\Sigma)) = \emptyset \\ &\iff \mathbf{V}_a(I) \subseteq Z(\Sigma) = \mathbf{V}_a(B(\Sigma)) \\ &\iff B(\Sigma)^\ell \subseteq I \text{ for some } \ell \geq 0, \end{aligned}$$

where the last equivalence uses the Nullstellensatz in $\mathbb{C}^{\Sigma(1)}$. \square

For \mathbb{C}^n and \mathbb{P}^n , the irrelevant ideal is $\langle 1 \rangle \subseteq \mathbb{C}[x_1, \dots, x_n]$ and $\langle x_0, \dots, x_n \rangle \subseteq \mathbb{C}[x_0, \dots, x_n]$ respectively. Furthermore, for \mathbb{C}^n , the grading on $\mathbb{C}[x_1, \dots, x_n]$ is trivial, so that every ideal is homogeneous. Thus the toric weak Nullstellensatz implies the classical version of the weak Nullstellensatz for both \mathbb{C}^n and \mathbb{P}^n .

The relation between ideals and varieties is not perfect because different ideals can define the same subvariety. In \mathbb{C}^n and \mathbb{P}^n , we avoid this by using radical ideals:

- For \mathbb{C}^n : There is a bijective correspondence

$$\{\text{closed subvarieties of } \mathbb{C}^n\} \longleftrightarrow \{\text{radical ideals } I \subseteq \mathbb{C}[x_1, \dots, x_n]\}.$$

- For \mathbb{P}^n : There is a bijective correspondence

$$\{\text{closed subvarieties of } \mathbb{P}^n\} \longleftrightarrow \left\{ \begin{array}{l} \text{radical homogeneous ideals} \\ I \subseteq \langle x_0, \dots, x_n \rangle \subseteq \mathbb{C}[x_0, \dots, x_n] \end{array} \right\}.$$

Here is the toric version of this correspondence.

Proposition 5.2.7 (The Toric Ideal-Variety Correspondence). *Let X_Σ be a simplicial toric variety. Then there is a bijective correspondence*

$$\{\text{closed subvarieties of } X_\Sigma\} \longleftrightarrow \left\{ \begin{array}{l} \text{radical homogeneous} \\ \text{ideals } I \subseteq B(\Sigma) \subseteq S \end{array} \right\}.$$

Proof. Given a closed subvariety $Y \subseteq X_\Sigma$, we can find a homogeneous ideal $I \subseteq S$ with $\mathbf{V}(I) = Y$ by Proposition 5.2.4. Then \sqrt{I} is also homogeneous and satisfies $\mathbf{V}(\sqrt{I}) = \mathbf{V}(I) = Y$, so we may assume that I is radical. Since

$$\mathbf{V}_a(I \cap B(\Sigma)) = \mathbf{V}_a(I) \cup \mathbf{V}_a(B(\Sigma)) = \mathbf{V}_a(I) \cup Z(\Sigma)$$

in $\mathbb{C}^{\Sigma(1)}$, we see that $I \cap B(\Sigma) \subseteq B(\Sigma)$ is a radical homogeneous ideal satisfying $\mathbf{V}(I \cap B(\Sigma)) = Y$. This proves surjectivity.

To prove injectivity, suppose that $I, J \subseteq B(\Sigma)$ are radical homogeneous ideals with $\mathbf{V}(I) = \mathbf{V}(J)$ in X_Σ . Then

$$\mathbf{V}_a(I) \cap (\mathbb{C}^{\Sigma(1)} \setminus Z(\Sigma)) = \mathbf{V}_a(J) \cap (\mathbb{C}^{\Sigma(1)} \setminus Z(\Sigma)).$$

However, $I, J \subseteq B(\Sigma)$ implies that $Z(\Sigma)$ is contained in $\mathbf{V}_a(I)$ and $\mathbf{V}_a(J)$. Hence the above equality implies

$$\mathbf{V}_a(I) = \mathbf{V}_a(J),$$

so that $I = J$ by the Nullstellensatz since I and J are radical. \square

For general ideals, another way to recover injectivity is to work with closed subschemes rather than closed subvarieties. We will say more about this in the appendix to Chapter 6.

When X_Σ is not simplicial, there is still a relation between ideals in the total coordinate ring and closed subvarieties of X_Σ .

Proposition 5.2.8. *Let S be the total coordinate ring of the toric variety X_Σ . Then:*

(a) *If $I \subseteq S$ is a homogeneous ideal, then*

$$\mathbf{V}(I) = \{p \in X_\Sigma \mid \text{there is } x \in \pi^{-1}(p) \text{ with } f(x) = 0 \text{ for all } f \in I\}$$

is a closed subvariety of X_Σ .

(b) *All closed subvarieties of X_Σ arise this way.*

Proof. The proof is identical to the proof of Proposition 5.2.4. □

The main difference between Propositions 5.2.4 and 5.2.8 is the phrase “there is $x \in \pi^{-1}(p)$ ”. In the simplicial case, all such x are related by the group G , while this may fail in the non-simplicial case. One consequence is that the ideal-variety correspondence of Proposition 5.2.7 breaks down in the nonsimplicial case. Here is a simple example.

Example 5.2.9. In Example 5.1.14 we described the quotient representation of $U_\sigma = \mathbb{C}^4 // \mathbb{C}^*$ for the cone $\sigma = \text{Cone}(e_1, e_2, e_1 + e_3, e_2 + e_3) \subseteq \mathbb{R}^3$, and in Example 5.0.2 we saw that the quotient map

$$\pi : \mathbb{C}^4 \longrightarrow U_\sigma = \mathbf{V}(xy - zw) \subseteq \mathbb{C}^4$$

is given by $\pi(a_1, a_2, a_3, a_4) = (a_1a_3, a_2a_4, a_1a_4, a_2a_3)$. Note that the irrelevant ideal is $B(\Sigma) = \mathbb{C}[x_1, x_2, x_3, x_4]$.

The ideals $I_1 = \langle x_1, x_2 \rangle$ and $I_2 = \langle x_3, x_4 \rangle$ are distinct radical homogeneous ideals contained in $B(\Sigma)$ that give the same subvariety in U_σ :

$$\mathbf{V}(I_1) = \pi(\mathbf{V}_a(I_1)) = \pi(\mathbb{C}^2 \times \{0\}) = \{0\} \in U_\sigma$$

$$\mathbf{V}(I_2) = \pi(\mathbf{V}_a(I_2)) = \pi(\{0\} \times \mathbb{C}^2) = \{0\} \in U_\sigma.$$

Thus Proposition 5.2.7 fails to hold for this toric variety. ◇

Local Coordinates. Let X_Σ be an n -dimensional toric variety. When Σ contains a smooth cone σ of dimension n , we get an affine open set

$$U_\sigma \subseteq X_\Sigma \quad \text{with} \quad U_\sigma \simeq \mathbb{C}^n$$

The usual coordinates for \mathbb{C}^n are compatible with the homogeneous coordinates for X_Σ in the following sense. The cone σ gives the map $\phi_\sigma : \mathbb{C}^{\sigma(1)} \rightarrow \mathbb{C}^{\Sigma(1)}$ that sends $(a_\rho)_{\rho \in \sigma(1)}$ to the point $(b_\rho)_{\rho \in \Sigma(1)}$ defined by

$$b_\rho = \begin{cases} a_\rho & \rho \in \sigma(1) \\ 1 & \text{otherwise.} \end{cases}$$

Proposition 5.2.10. *Let $\sigma \in \Sigma$ be a smooth cone of dimension $n = \dim X_\Sigma$ and let $\phi_\sigma : \mathbb{C}^{\sigma(1)} \rightarrow \mathbb{C}^{\Sigma(1)}$ be defined as above. Then we have a commutative diagram*

$$\begin{array}{ccc} \mathbb{C}^{\sigma(1)} & \xrightarrow{\phi_\sigma} & \mathbb{C}^{\Sigma(1)} \setminus Z(\Sigma) \\ \downarrow & & \downarrow \\ U_\sigma & \hookrightarrow & X_\Sigma, \end{array}$$

where the vertical maps are the quotient maps from Theorem 5.1.10. Furthermore, the vertical map on the left is an isomorphism.

Proof. We first show commutativity. In the proof of Theorem 5.1.10 we saw that $\pi^{-1}(U_\sigma) = U_{\tilde{\sigma}}$. Since the image of ϕ_σ lies in $U_{\tilde{\sigma}}$, we are reduced to the diagram

$$\begin{array}{ccc} \mathbb{C}^{\sigma(1)} & \xrightarrow{\phi_\sigma} & U_{\tilde{\sigma}} \\ & \searrow & \swarrow \\ & U_\sigma & \end{array}$$

Since everything is affine, we can consider the corresponding diagram of coordinate rings

$$\begin{array}{ccc} \mathbb{C}[x_\rho \mid \rho \in \sigma(1)] & \xleftarrow{\phi_\sigma^*} & \mathbb{C}[x_\rho \mid \rho \in \Sigma(1)]_{x^{\hat{\sigma}}} \\ & \swarrow \alpha^* & \searrow \beta^* \\ & \mathbb{C}[\sigma^\vee \cap M] & \end{array}$$

where $\alpha^*(\chi^m) = \prod_{\rho \in \sigma(1)} x_\rho^{\langle m, u_\rho \rangle}$ and $\beta^*(\chi^m) = \prod_{\rho \in \Sigma(1)} x_\rho^{\langle m, u_\rho \rangle}$ for $m \in \sigma^\vee \cap M$. It is clear that $\phi_\sigma^* \circ \beta^* = \alpha^*$, and commutativity follows.

For the final assertion, note that α^* is an isomorphism since the u_ρ , $\rho \in \sigma(1)$, form a basis of N by our assumption on σ . This completes the proof. \square

It follows that if a closed subvariety $Y \subseteq X_\Sigma$ is defined by an ideal $I \subseteq S$, then the affine piece $Y \cap U_\sigma \subseteq U_\sigma \simeq \mathbb{C}^{\sigma(1)}$ is defined by the dehomogenized ideal $\tilde{I} \subseteq \mathbb{C}[x_\rho \mid \rho \in \sigma(1)]$ obtained by setting $x_\rho = 1$, $\rho \notin \sigma(1)$, in all polynomials of I . We will give examples of this below, and in §5.4, we will explore the corresponding notion of homogenization.

Proposition 5.2.10 can be generalized to any cone $\sigma \in \Sigma$ satisfying $\dim \sigma = \dim X_\Sigma$ (Exercise 5.2.5).

Example 5.2.11. In Example 5.1.15 we described the quotient construction of the blowup of \mathbb{C}^2 at the origin. This variety can be expressed as the union $\text{Bl}_0(\mathbb{C}^2) = U_{\sigma_1} \cup U_{\sigma_2}$, where $\sigma_1, \sigma_2 \in \Sigma$ are as in Example 5.1.15.

The map $\text{Bl}_0(\mathbb{C}^2) \rightarrow \mathbb{C}^2$ is given by $(t, x, y) \mapsto (tx, ty)$ in homogeneous coordinates. Combining this with the local coordinate maps from Proposition 5.2.10, we obtain

$$\begin{aligned} U_{\sigma_1} \subseteq X_\Sigma &\rightarrow \mathbb{C}^2 : (t, x) \mapsto (t, x, 1) \mapsto (tx, t) \\ U_{\sigma_2} \subseteq X_\Sigma &\rightarrow \mathbb{C}^2 : (t, y) \mapsto (t, 1, y) \mapsto (t, ty). \end{aligned}$$

Consider the curve $f(x, y) = 0$ in the plane \mathbb{C}^2 , where $f(x, y) = x^3 - y^2$. We study this on the blowup $\text{Bl}_0(\mathbb{C}^2)$ using local coordinates as follows:

- On U_{σ_1} , we get $f(tx, t) = 0$, i.e., $(tx)^3 - t^2 = t^2(tx^3 - 1) = 0$. Since $t = 0$ defines the exceptional locus, we get the proper transform $tx^3 - 1 = 0$.
- On U_{σ_2} , we get $f(t, ty) = 0$, i.e., $t^3 - (ty)^2 = t^2(t - y^2) = 0$, with proper transform $t - y^2 = 0$.

Hence the proper transform is a smooth curve in $\text{Bl}_0(\mathbb{C}^2)$. This method of studying the blowup of a curve is explained in many elementary texts on algebraic geometry, such as [145, p. 100].

We relate this to the homogeneous coordinates of $\text{Bl}_0(\mathbb{C}^2)$ as follows. Using the above map $X_\Sigma \rightarrow \mathbb{C}^2$, we get the curve in X_Σ defined by $f(tx, ty) = 0$, i.e., $(tx)^3 - (ty)^2 = t^2(tx^3 - y^2) = 0$. Hence the proper transform is $tx^3 - y^2 = 0$. Then:

- Setting $y = 1$ gives the proper transform $tx^3 - 1 = 0$ on U_{σ_1} .
- Setting $x = 1$ gives the proper transform $t - y^2 = 0$ on U_{σ_2} .

Hence the “local” proper transforms computed above are obtained from the homogeneous proper transform by setting appropriate coordinates equal to 1. \diamond

Exercises for §5.2.

5.2.1. Prove (5.2.1).

5.2.2. Show that the total coordinate ring of the weighted projective space $\mathbb{P}(q_0, \dots, q_n)$ is $\mathbb{C}[x_0, \dots, x_n]$ where $\deg(x_i) = q_i$. Hint: See Example 5.1.13.

5.2.3. Prove the claims made about the total coordinate ring of the product $\mathbb{P}^n \times \mathbb{P}^m$ made in Example 5.2.2.

5.2.4. Prove the claims made about the class group and the total coordinate ring of the blowup of \mathbb{P}^2 at the origin made in Example 5.2.3.

5.2.5. Let X_Σ be the toric variety of the fan Σ and assume as usual that X_Σ has no torus factors. A subfan $\Sigma' \subseteq \Sigma$ is *full* if $\Sigma' = \{\sigma \in \Sigma \mid \sigma(1) \subseteq \Sigma'(1)\}$. Consider a full subfan $\Sigma' \subseteq \Sigma$ with the property that $X_{\Sigma'}$ has no torus factors.

(a) Define the map $\phi : \mathbb{C}^{\Sigma'(1)} \rightarrow \mathbb{C}^{\Sigma(1)}$ by sending $(a_\rho)_{\rho \in \Sigma'(1)}$ to the point $(b_\rho)_{\rho \in \Sigma(1)}$ given by

$$b_\rho = \begin{cases} a_\rho & \rho \in \Sigma'(1) \\ 1 & \text{otherwise.} \end{cases}$$

Prove that there is a commutative diagram

$$\begin{array}{ccc} \mathbb{C}^{\Sigma'(1)} \setminus Z(\Sigma') & \xrightarrow{\phi} & \mathbb{C}^{\Sigma(1)} \setminus Z(\Sigma) \\ \downarrow & & \downarrow \\ X_{\Sigma'} & \xrightarrow{\quad} & X_{\Sigma}, \end{array}$$

where the vertical maps are the quotient maps from Theorem 5.1.10.

- (b) Explain how part (a) generalizes Proposition 5.2.10.
 (c) Use part (a) to give a version of Proposition 5.2.10 that applies to any cone $\sigma \in \Sigma$ satisfying $\dim \sigma = \dim X_{\Sigma}$.

5.2.6. The quintic $y^2 = x^5$ in \mathbb{C}^2 has a unique singular point at the origin. We will resolve the singularity using successive blowups.

- (a) Show that the proper transform of this curve in $\text{Bl}_0(\mathbb{C}^2)$ is defined by $y^2 - t^3x^5 = 0$. This uses the homogeneous coordinates t, x, y from Example 5.2.3.
 (b) Show that the proper transform is smooth on U_{σ_1} but singular on U_{σ_2} .
 (c) Subdivide σ_2 to obtain a smooth fan Σ' . The toric variety $X_{\Sigma'}$ has variables u, t, x, y , where u corresponds to the ray that subdivides σ_2 . Show that $\text{Cl}(X_{\Sigma'}) \simeq \mathbb{Z}^2$ with $\deg(u) = (0, -1)$, $\deg(t) = (-1, 0)$, $\deg(x) = (1, 1)$, $\deg(y) = (1, 2)$.
 (d) Show that $(u, t, x, y) \mapsto (utx, u^2ty)$ defines a toric morphism $X_{\Sigma'} \rightarrow \mathbb{C}^2$ and use this to show that the proper transform of the quintic in \mathbb{C}^2 is defined by $y^2 - ut^3x^5 = 0$.
 (e) Show that the proper transform is smooth by inspecting it in local coordinates.

5.2.7. Adapt the method Exercise 5.2.6 to desingularize $y^2 = x^{2n+1}$, $n \geq 1$ an integer.

5.2.8. Given an ideal I in a commutative ring R , its *Rees algebra* is the graded ring

$$R[I] = \bigoplus_{i=0}^{\infty} I^i t^i \subseteq R[t],$$

where t is a new variable and $I^0 = R$. There is also the *extended Rees algebra*

$$R[I, t^{-1}] = \bigoplus_{i \in \mathbb{Z}} I^i t^i \subseteq R[t, t^{-1}],$$

where $I^i = R$ for $i \leq 0$. These rings are graded by letting $\deg(t) = 1$, so that elements of R have degree 0. See [29, 4.4] and §11.3 for more about Rees algebras.

- (a) When $I = \langle x, y \rangle \subseteq R = \mathbb{C}[x, y]$, prove that the extended Rees algebra $R[I, t^{-1}]$ is the polynomial ring $\mathbb{C}[xt, yt, t^{-1}]$.
 (b) Prove that the ring of part (a) is isomorphic to the total coordinate ring of the blowup of \mathbb{C}^2 at the origin.
 (c) Generalize parts (a) and (b) to the case of $I = \langle x_1, \dots, x_n \rangle \subseteq R = \mathbb{C}[x_1, \dots, x_n]$.

§5.3. Sheaves on Toric Varieties

Given a toric variety X_{Σ} , we show that graded modules over the total coordinate ring $S = \mathbb{C}[x_{\rho} \mid \rho \in \Sigma(1)]$ give quasicoherent sheaves on X_{Σ} . We continue to assume that X_{Σ} has no torus factors.

Graded Modules. The grading on S gives a direct sum decomposition

$$S = \bigoplus_{\alpha \in \text{Cl}(X_\Sigma)} S_\alpha$$

such that $S_\alpha \cdot S_\beta \subseteq S_{\alpha+\beta}$ for all $\alpha, \beta \in \text{Cl}(X_\Sigma)$.

Definition 5.3.1. An S -module M is **graded** if it has a decomposition

$$M = \bigoplus_{\alpha \in \text{Cl}(X_\Sigma)} M_\alpha$$

such that $S_\alpha \cdot M_\beta \subseteq M_{\alpha+\beta}$ for all $\alpha, \beta \in \text{Cl}(X_\Sigma)$. Given $\alpha \in \text{Cl}(X_\Sigma)$, the **shift** $M(\alpha)$ is the graded S -module satisfying

$$M(\alpha)_\beta = M_{\alpha+\beta}$$

for all $\beta \in \text{Cl}(X_\Sigma)$.

The passage from a graded S -module to a quasicoherent sheaf on X_Σ requires some tools from the proof of Theorem 5.1.10. A cone $\sigma \in \Sigma$ gives the monomial $x^{\hat{\sigma}} = \prod_{\rho \notin \sigma(1)} x_\rho \in S$, and by (5.1.4), the map $\chi^m \mapsto x^{\langle m \rangle} = \prod_{\rho} x_\rho^{\langle m, u_\rho \rangle}$ induces an isomorphism

$$\pi_\sigma^* : \mathbb{C}[\sigma^\vee \cap M] \xrightarrow{\sim} (S_{x^{\hat{\sigma}}})^G \subseteq S_{x^{\hat{\sigma}}},$$

where $S_{x^{\hat{\sigma}}}$ is the localization of S at $x^{\hat{\sigma}}$. Since monomials are homogeneous, $S_{x^{\hat{\sigma}}}$ is also graded by $\text{Cl}(X_\Sigma)$, and its elements of degree 0 are precisely its G -invariants (Exercise 5.3.1), i.e., $(S_{x^{\hat{\sigma}}})_0 = (S_{x^{\hat{\sigma}}})^G$. Hence the above isomorphism becomes

$$(5.3.1) \quad \pi_\sigma^* : \mathbb{C}[\sigma^\vee \cap M] \xrightarrow{\sim} (S_{x^{\hat{\sigma}}})_0.$$

These isomorphisms glue together just as we would hope.

Lemma 5.3.2. *Let $\tau = \sigma \cap m^\perp$ be a face of σ . Then $(S_{x^{\hat{\tau}}})_0 = ((S_{x^{\hat{\sigma}}})_0)_{\pi_\sigma^*(\chi^m)}$, and there is a commutative diagram of isomorphisms*

$$\begin{array}{ccc} (S_{x^{\hat{\sigma}}})_0 & \longrightarrow & ((S_{x^{\hat{\tau}}})_0)_{\pi_\sigma^*(\chi^m)} \\ \downarrow & & \downarrow \\ \mathbb{C}[\sigma^\vee \cap M] & \longrightarrow & \mathbb{C}[\tau^\vee \cap M]_{\chi^m}. \end{array}$$

Proof. Since $\tau = \sigma \cap m^\perp$, we have $\langle m, u_\rho \rangle = 0$ when $\rho \in \tau(1)$ and $\langle m, u_\rho \rangle > 0$ when $\rho \in \sigma(1) \setminus \tau(1)$. This means that $S_{x^{\hat{\tau}}} = (S_{x^{\hat{\sigma}}})_{\pi_\sigma^*(\chi^m)}$. Taking elements of degree zero commutes with localization, hence $(S_{x^{\hat{\tau}}})_0 = ((S_{x^{\hat{\sigma}}})_0)_{\pi_\sigma^*(\chi^m)}$. The vertical maps in the diagram come from (5.3.1), and the horizontal maps are localization. In Exercise 5.3.2 you will chase the diagram to show that it commutes. \square

From Modules to Sheaves. We now construct the sheaf of a graded module.

Proposition 5.3.3. *Let M be a graded S -module. Then there is a quasicoherent sheaf \tilde{M} on X_Σ such that for every $\sigma \in \Sigma$, the sections of \tilde{M} over $U_\sigma \subseteq X_\Sigma$ are*

$$\Gamma(U_\sigma, \tilde{M}) = (M_{x^{\hat{\sigma}}})_0.$$

Proof. Since M is a graded S -module, it is immediate that $M_{x^{\hat{\sigma}}}$ is a graded $S_{x^{\hat{\sigma}}}$ -module. Hence $(M_{x^{\hat{\sigma}}})_0$ is an $(S_{x^{\hat{\sigma}}})_0$ -module, which induces a sheaf $(M_{x^{\hat{\sigma}}})_0^\sim$ on $U_\sigma = \text{Spec}(\mathbb{C}[\sigma^\vee \cap M]) = \text{Spec}((S_{x^{\hat{\sigma}}})_0)$. The argument of Lemma 5.3.2 applies verbatim to show that

$$(M_{x^{\hat{\tau}}})_0 = ((M_{x^{\hat{\sigma}}})_0)_{\pi_\sigma^*(x^m)}.$$

Thus the sheaves $(M_{x^{\hat{\sigma}}})_0^\sim$ patch to give a sheaf \tilde{M} on X_Σ which is quasicoherent by construction. \square

Example 5.3.4. The total coordinate ring of \mathbb{P}^n is $S = \mathbb{C}[x_0, \dots, x_n]$ with the standard grading where every variable has degree 1. The quasicoherent sheaf on \mathbb{P}^n associated to a graded S -module was first described by Serre in his foundational paper *Faisceaux algébriques cohérents* [154], called FAC for short. \diamond

An important special case is when M is a finitely generated graded S -module. We will need the following finiteness result to understand the sheaf \tilde{M} .

Lemma 5.3.5. *$(S_{x^{\hat{\sigma}}})_\alpha$ is finitely generated as a $(S_{x^{\hat{\sigma}}})_0$ -module for all $\sigma \in \Sigma$ and $\alpha \in \text{Cl}(X_\Sigma)$.*

Proof. Write $\alpha = [\sum_\rho a_\rho D_\rho]$ and consider rational polyhedral cone

$$\hat{\sigma} = \{(m, \lambda) \in M_{\mathbb{R}} \times \mathbb{R} \mid \lambda \geq 0, \langle m, u_\rho \rangle \geq -\lambda a_\rho \text{ for all } \rho\} \subseteq M_{\mathbb{R}} \times \mathbb{R}.$$

By Gordan's Lemma, $\hat{\sigma} \cap (M \times \mathbb{Z})$ is a finitely generated semigroup. Let the generators with last coordinate equal to 1 be $(m_1, 1), \dots, (m_r, 1)$. Then you will prove in Exercise 5.3.3 that the monomials $\prod_\rho x_\rho^{\langle m_i, u_\rho \rangle + a_\rho}$, $i = 1, \dots, r$, generate $(S_{x^{\hat{\sigma}}})_\alpha$ as a $(S_{x^{\hat{\sigma}}})_0$ -module. \square

Here are some coherent sheaves on X_Σ .

Proposition 5.3.6. *The sheaf \tilde{M} on X_Σ is coherent when M is a finitely generated graded S -module.*

Proof. Because M is graded, we may assume its generators are homogeneous of degrees $\alpha_1, \dots, \alpha_r$. Given $\sigma \in \Sigma$, it follows immediately that $M_{x^{\hat{\sigma}}}$ is finitely generated over $S_{x^{\hat{\sigma}}}$ with generators in the same degrees. However, we need to be careful when taking elements of degree 0. Multiply a generator of degree α_i by the $(S_{x^{\hat{\sigma}}})_0$ -module generators of $(S_{x^{\hat{\sigma}}})_{-\alpha_i}$ (finitely many by the previous lemma). Doing this for all i gives finitely many elements in $(M_{x^{\hat{\sigma}}})_0$ that generate $(M_{x^{\hat{\sigma}}})_0$ as a $(S_{x^{\hat{\sigma}}})_0$ -module (Exercise 5.3.3). It follows that \tilde{M} is coherent. \square

Given $\alpha \in \text{Cl}(X_\Sigma)$, the shifted S -module $S(\alpha)$ gives a coherent sheaf on X_Σ denoted $\mathcal{O}_{X_\Sigma}(\alpha)$. This is a sheaf we already know.

Proposition 5.3.7. *Fix $\alpha \in \text{Cl}(X_\Sigma)$. Then:*

- (a) *There is a natural isomorphism $S_\alpha \simeq \Gamma(X_\Sigma, \mathcal{O}_{X_\Sigma}(\alpha))$.*
- (b) *If $D = \sum_\rho a_\rho D_\rho$ is a Weil divisor satisfying $\alpha = [D]$, then*

$$\mathcal{O}_{X_\Sigma}(D) \simeq \mathcal{O}_{X_\Sigma}(\alpha).$$

Proof. By definition, the sections of $\mathcal{O}_{X_\Sigma}(\alpha)$ over U_σ are

$$\Gamma(U_\sigma, \mathcal{O}_{X_\Sigma}(\alpha)) = (S(\alpha)_{x^{\hat{\sigma}}})_0 = (S_{x^{\hat{\sigma}}})_\alpha$$

for $\sigma \in \Sigma$. Since the open cover $\{U_\sigma\}_{\sigma \in \Sigma}$ of X_Σ satisfies $U_\sigma \cap U_\tau = U_{\sigma \cap \tau}$, the sheaf axiom gives the exact sequence

$$0 \longrightarrow \Gamma(X_\Sigma, \mathcal{O}_{X_\Sigma}(\alpha)) \longrightarrow \prod_\sigma (S_{x^{\hat{\sigma}}})_\alpha \rightrightarrows \prod_{\sigma, \tau} (S_{x^{\widehat{\sigma \cap \tau}}})_\alpha.$$

The localization $(S_{x^{\hat{\sigma}}})_\alpha$ has a basis consisting of all Laurent monomials $\prod_\rho x_\rho^{b_\rho}$ of degree α such that $b_\rho \geq 0$ for all $\rho \in \sigma(1)$. Then the exact sequence implies that $\Gamma(X_\Sigma, \mathcal{O}_{X_\Sigma}(\alpha))$ basis consisting of all Laurent monomials $\prod_\rho x_\rho^{b_\rho}$ of degree α such that $b_\rho \geq 0$ for all $\rho \in \Sigma(1)$. These are precisely the monomials in S of degree α , which gives the desired isomorphism $S_\alpha \simeq \Gamma(X_\Sigma, \mathcal{O}_{X_\Sigma}(\alpha))$.

We turn to part (b). Given a Weil divisor $D = \sum_\rho a_\rho D_\rho$ with $\alpha = [D]$, we need to construct a sheaf isomorphism $\mathcal{O}_{X_\Sigma}(D) \simeq \mathcal{O}_{X_\Sigma}(\alpha)$. By the above description of the sections over U_σ , it suffices to prove that for every $\sigma \in \Sigma$, we have isomorphisms

$$(5.3.2) \quad \Gamma(U_\sigma, \mathcal{O}_{X_\Sigma}(D)) \simeq (S_{x^{\hat{\sigma}}})_\alpha.$$

compatible with inclusions $U_\tau \subseteq U_\sigma$ induced by $\tau \preceq \sigma$ in Σ .

To construct this isomorphism, we apply Proposition 4.3.3 to U_σ to obtain

$$\Gamma(U_\sigma, \mathcal{O}_{X_\Sigma}(D)) = \bigoplus_{\substack{m \in M \\ \langle m, u_\rho \rangle \geq a_\rho, \rho \in \sigma(1)}} \mathbb{C} \cdot \chi^m.$$

A lattice point $m \in M$ gives the Laurent monomial

$$(5.3.3) \quad x^{\langle m, D \rangle} = \prod_\rho x_\rho^{\langle m, u_\rho \rangle + a_\rho}.$$

When $\langle m, u_\rho \rangle \geq -a_\rho$ for $\rho \in \Sigma(1)$, this lies in $S_{x^{\hat{\sigma}}}$, and in fact $x^{\langle m, D \rangle} \in (S_{x^{\hat{\sigma}}})_\alpha$ since

$$\deg(x^{\langle m, D \rangle}) = [\sum_\rho (\langle m, u_\rho \rangle + a_\rho) D_\rho] = [\text{div}(\chi^m) + D] = [D] = \alpha.$$

We claim that map $\chi^m \mapsto x^{\langle m, D \rangle}$ induces the desired isomorphism (5.3.2).

Suppose that $\chi^m, \chi^{m'}$ map to the same monomial. Then $\langle m, u_\rho \rangle = \langle m', u_\rho \rangle$ for all ρ . This implies $m = m'$ since X_Σ has no torus factors. Furthermore, if

$x^b = \prod_{\rho} x_{\rho}^{b_{\rho}} \in (S_{x^{\hat{\sigma}}})_{\alpha}$, then $[\sum_{\rho} b_{\rho} D_{\rho}] = \alpha = [\sum_{\rho} a_{\rho} D_{\rho}]$, so that there is $m \in M$ such that $b_{\rho} = \langle m, u_{\rho} \rangle + a_{\rho}$ for all ρ . Since x^b is a monomial in $S_{x^{\hat{\sigma}}}$, $b_{\rho} \geq 0$ for $\rho \in \sigma(1)$, hence $\langle m, u_{\rho} \rangle \geq -a_{\rho}$ for $\rho \in \sigma(1)$. Then $\chi^m \in \Gamma(U_{\sigma}, \mathcal{O}_{X_{\Sigma}}(D))$ maps to x^b . This defines an isomorphism (5.3.2) which is easily seen to be compatible with the inclusion of faces. \square

Example 5.3.8. For \mathbb{P}^n we have $S = \mathbb{C}[x_0, \dots, x_n]$ with the standard grading by $\mathbb{Z} = \text{Cl}(\mathbb{P}^n)$. Then $\mathcal{O}_{\mathbb{P}^n}(k)$ is the sheaf associated to $S(k)$ for $k \in \mathbb{Z}$. The classes of the toric divisors $D_0 \sim \dots \sim D_n$ correspond to $1 \in \mathbb{Z}$, so that

$$\mathcal{O}_{\mathbb{P}^n}(k) \simeq \mathcal{O}_{\mathbb{P}^n}(kD_0) \simeq \dots \simeq \mathcal{O}_{\mathbb{P}^n}(kD_n).$$

Thus $\mathcal{O}_{\mathbb{P}^n}(k)$ is a canonical model for the sheaf $\mathcal{O}_{\mathbb{P}^n}(kD_i)$. This justifies what we did in Example 4.3.1.

Also note that when $k \geq 0$, we have

$$\Gamma(\mathbb{P}^n, \mathcal{O}_{\mathbb{P}^n}(k)) = S_k.$$

Hence global sections of $\mathcal{O}_{\mathbb{P}^n}(k)$ are homogeneous polynomials in x_0, \dots, x_n of degree k , which agrees with what we computed in Example 4.3.6. \diamond

Sheaves versus Modules. An important result is that *all* quasicoherent sheaves on X_{Σ} come from graded modules.

Proposition 5.3.9. *Let \mathcal{F} be a quasicoherent sheaf on X_{Σ} . Then:*

- (a) *There is a graded S -module M such that $\tilde{M} \simeq \mathcal{F}$.*
- (b) *If \mathcal{F} is coherent, then M can be chosen to be finitely generated over S .*

The proof will be given in the appendix to Chapter 6 since it involves tensor products of sheaves from §6.0.

Although the map $M \mapsto \tilde{M}$ is surjective (up to isomorphism), it is far from injective. In particular, there are nontrivial graded modules that give the trivial sheaf. This phenomenon is well-known for \mathbb{P}^n , where a finitely generated graded module M over $S = \mathbb{C}[x_0, \dots, x_n]$ gives the trivial sheaf on \mathbb{P}^n if and only if $M_{\ell} = 0$ for $\ell \gg 0$ (see [77, Ex. II.5.9]). This is equivalent to

$$\langle x_0, \dots, x_n \rangle^{\ell} M = 0$$

for $\ell \gg 0$ (Exercise 5.3.4). Since $\langle x_0, \dots, x_n \rangle$ is the irrelevant ideal for \mathbb{P}^n , this suggests a toric generalization. In the smooth case, we have the following result.

Proposition 5.3.10. *Let $B(\Sigma) \subseteq S$ be the irrelevant ideal of S for a smooth toric variety X_{Σ} , and let M be a finitely generated graded S -module. Then $\tilde{M} = 0$ if and only if $B(\Sigma)^{\ell} M = 0$ for $\ell \gg 0$.*

Proof. First observe that $\tilde{M} = 0$ if and only if it vanishes on each affine open subset $U_{\sigma} \subseteq X_{\Sigma}$. But on an affine variety, the correspondence between quasicoherent

sheaves and modules is bijective (see [77, Cor. II.5.5]). Hence $\tilde{M} = 0$ if and only if $(M_{x^{\hat{\sigma}}})_0 = 0$ for all $\sigma \in \Sigma$.

First suppose that $B(\Sigma)^\ell M = 0$ for some $\ell \geq 0$. Then $(x^{\hat{\sigma}})^\ell M = 0$, which easily implies that $M_{x^{\hat{\sigma}}} = 0$. Then $\tilde{M} = 0$ follows from the previous paragraph. This part of the argument works for any toric variety.

For the converse, we have $(M_{x^{\hat{\sigma}}})_0 = 0$ for all $\sigma \in \Sigma$. Given $h \in M_\alpha$, we will show that $(x^{\hat{\sigma}})^\ell h = 0$ for some $\ell \geq 0$, which will imply $B(\Sigma)^\ell M = 0$ for $\ell \gg 0$ since M is finitely generated. Let $\alpha = [D]$, where $D = \sum_\rho a_\rho D_\rho$. Since σ is smooth, there $m_\sigma \in M$ such that $\langle m_\sigma, u_\rho \rangle = -a_\rho$ for all $\rho \in \sigma(1)$ (this is part of the Cartier data for D). Replacing D with $D + \text{div}(\chi^{m_\sigma})$, we may assume that $D = \sum_{\rho \notin \sigma(1)} a_\rho D_\rho$. Now set $k = \max(0, a_\rho \mid \rho \notin \sigma(1))$ and observe that

$$x^b = (x^{\hat{\sigma}})^k \prod_{\rho \notin \sigma(1)} x_\rho^{-a_\rho} = \prod_{\rho \notin \sigma(1)} x_\rho^{k-a_\rho} \in S.$$

Furthermore, $x^b h / (x^{\hat{\sigma}})^k \in M_{x^{\hat{\sigma}}}$ has degree 0. Hence $x^b h / (x^{\hat{\sigma}})^k = 0$ in $M_{x^{\hat{\sigma}}}$, which by the definition of localization implies that there is $s \geq 0$ with

$$(x^{\hat{\sigma}})^s \cdot x^b h = 0 \text{ in } M.$$

Since x^b involves only x_ρ for $\rho \notin \sigma(1)$, we can find $x^a \in S$ such that $x^a \cdot x^b$ is a power of $x^{\hat{\sigma}}$. Hence multiplying the above equation by x^a implies $(x^{\hat{\sigma}})^\ell h = 0$ for some $\ell \geq 0$, as desired. \square

Unfortunately, the situation is more complicated when X_Σ is not smooth. Here is an example to show what can go wrong when X_Σ is simplicial.

Example 5.3.11. The weighted projective space $\mathbb{P}(1, 1, 2)$ has total coordinate ring $S = \mathbb{C}[x, y, z]$, where x, y have degree 1 and z has degree 2, and the irrelevant ideal is $B(\Sigma) = \langle x, y, z \rangle$. The graded S -module $M = S(1)/(xS(1) + yS(1))$ has only elements of odd degree. Then $(M_z)_0 = 0$ since z has degree 2, and it is clear that $(M_x)_0 = (M_y)_0 = 0$. It follows that $\tilde{M} = 0$, yet one easily checks that $B(\Sigma)^\ell M = z^\ell M \neq 0$ for all $\ell \geq 0$. Thus Proposition 5.3.10 fails for $\mathbb{P}(1, 1, 2)$. \diamond

Exercise 5.3.5 explores a version of Proposition 5.3.10 that applies to simplicial toric varieties. The condition that $B(\Sigma)^\ell M = 0$ is replaced with the weaker condition that $B(\Sigma)^\ell M_\alpha = 0$ for all $\alpha \in \text{Pic}(X_\Sigma)$.

We will say more about the relation between quasicoherent sheaves and graded S -modules in the appendix to Chapter 6.

Exercises for §5.3.

5.3.1. As described in §5.0, the action of G on $\mathbb{C}^{\Sigma(1)}$ induces an action of G on the total coordinate ring S . Also recall that $g \in G$ is a homomorphism $g : \text{Cl}(X_\Sigma) \rightarrow \mathbb{C}^*$.

- (a) Given $x^a \in S$ and $g \in G$, show that $g \cdot x^a = g^{-1}(\alpha)x^a$, where $\alpha = \text{deg}(x^a)$.

(b) Show that $S^G = S_0$ and that a similar result holds for the localization S_{x^b} .

5.3.2. Complete the proof of Lemma 5.3.2.

5.3.3. Complete the proofs of Lemma 5.3.5 and Proposition 5.3.6.

5.3.4. Let $S = \mathbb{C}[x_0, \dots, x_n]$ where $\deg(x_i) = 1$ for all i , and let M be a finitely generated graded S -module. Prove that $M_\ell = 0$ for $\ell \gg 0$ if and only if $B(\Sigma)^\ell M = 0$ for $\ell \gg 0$.

5.3.5. Let X_Σ be a simplicial toric variety and let M be a finitely generated graded S -module. Prove that $\tilde{M} = 0$ if and only if $B(\Sigma)^\ell M_\alpha = 0$ for all $\ell \gg 0$ and $\alpha \in \text{Pic}(X_\Sigma)$.

5.3.6. Let X_Σ be a smooth toric variety. State and prove a version of Proposition 5.3.10 that applies to arbitrary graded S -modules M . Also explain what happens when X_Σ is simplicial, as in Exercise 5.3.5.

§5.4. Homogenization and Polytopes

The final section of the chapter will explore the relation between torus-invariant divisors on a toric variety X_Σ and its total coordinate ring. We will also see that when X_Σ comes from a polytope P , the quotient construction of X_Σ relates nicely to the definition of projective toric variety given in Chapter 2.

Homogenization. When working with affine and projective space, one often needs to homogenize polynomials. This process generalizes nicely to the toric context. The full story involves characters, polyhedra, divisors, sheaves, and graded pieces of the total coordinate ring.

A Weil divisor $D = \sum_\rho a_\rho D_\rho$ on X_Σ gives the polyhedron

$$P_D = \{m \in M_{\mathbb{R}} \mid \langle m, u_\rho \rangle \geq -a_\rho \text{ for all } \rho \in \Sigma(1)\}.$$

Proposition 4.3.3 tells us that the global sections of the sheaf $\mathcal{O}_{X_\Sigma}(D)$ are spanned by characters coming from lattice points of P_D , i.e.,

$$\Gamma(X_\Sigma, \mathcal{O}_{X_\Sigma}(D)) = \bigoplus_{m \in P_D \cap M} \mathbb{C} \cdot \chi^m.$$

This relates to the total coordinate ring $S = \mathbb{C}[x_\rho \mid \rho \in \Sigma(1)]$ as follows. Given $m \in P_D \cap M$, the D -homogenization of χ^m is the monomial

$$x^{\langle m, D \rangle} = \prod_\rho x_\rho^{\langle m, u_\rho \rangle + a_\rho}$$

defined in (5.3.3). The inequalities defining P_D guarantee that $x^{\langle m, D \rangle}$ lies in S . Here are the basic properties of these monomials.

Proposition 5.4.1. *Assume that X_Σ has no torus factors. If D and P_D are as above and $\alpha = [D] \in \text{Cl}(X_\Sigma)$ is the divisor class of D , then:*

(a) *For each $m \in P_D \cap M$, the monomial $x^{\langle m, D \rangle}$ lies in S_α .*

(b) The map sending the character χ^m of $m \in P_D \cap M$ to the monomial $x^{\langle m, D \rangle}$ induces an isomorphism

$$\Gamma(X_\Sigma, \mathcal{O}_{X_\Sigma}(D)) \simeq S_\alpha.$$

Proof. Part (a) follows from the proof of Proposition 5.3.7. As for part (b), we use the same proposition to conclude that

$$\Gamma(X_\Sigma, \mathcal{O}_{X_\Sigma}(D)) \simeq \Gamma(X_\Sigma, \mathcal{O}_{X_\Sigma}(\alpha)) \simeq S_\alpha.$$

One easily sees that this isomorphism is given by $\chi^m \mapsto x^{\langle m, D \rangle}$. □

Here are some examples of homogenization.

Example 5.4.2. The fan for \mathbb{P}^n has ray generators $u_0 = -\sum_{i=1}^n e_i$ and $u_i = e_i$ for $i = 1, \dots, n$. This gives variables x_i and divisors D_i for $i = 0, \dots, n$. Since $M = \mathbb{Z}^n$, the character of $m = (b_1, \dots, b_n) \in \mathbb{Z}^n$ is the Laurent monomial $t^m = \prod_{i=1}^n t_i^{b_i}$.

For a positive integer d , the divisor $D = dD_0$ has polyhedron $P_D = d\Delta_n$, where Δ_n is the standard n -simplex. Given $m = (b_1, \dots, b_n) \in d\Delta_n$, its homogenization is

$$\begin{aligned} x^{\langle m, D \rangle} &= x_0^{\langle m, u_0 \rangle + d} x_1^{\langle m, u_1 \rangle + 0} \dots x_n^{\langle m, u_n \rangle + 0} \\ &= x_0^{-b_1 - \dots - b_n + d} x_1^{b_1} \dots x_n^{b_n} \\ &= x_0^d \left(\frac{x_1}{x_0}\right)^{b_1} \dots \left(\frac{x_n}{x_0}\right)^{b_n}, \end{aligned}$$

which is the usual way to homogenize $t^m = \prod_{i=1}^n t_i^{b_i}$ with respect to x_0 .

This monomial has degree $d = [dD_0] \in \text{Cl}(\mathbb{P}^n) = \mathbb{Z}$, in agreement with Proposition 5.4.1. The proposition also implies the standard fact that monomials of degree d in x_0, \dots, x_n correspond to lattice points in $d\Delta_n$. ◇

Example 5.4.3. For $\mathbb{P}^1 \times \mathbb{P}^1$, we have ray generators $u_1 = e_1, u_2 = -e_1, u_3 = e_2, u_4 = -e_2$ with corresponding variables x_i and divisors D_i . Given nonnegative integers k, ℓ , we get the divisor $D = kD_2 + \ell D_4$. The polyhedron P_D is the rectangle with vertices $(0, 0), (k, 0), (0, \ell), (k, \ell)$, and given $(a, b) \in P_D \cap \mathbb{Z}^2$, the Laurent monomial $t_1^a t_2^b$ homogenizes to

$$x_1^a x_2^{k-a} x_3^b x_4^{\ell-b} = x_2^k x_4^\ell \left(\frac{x_1}{x_2}\right)^a \left(\frac{x_3}{x_4}\right)^b,$$

which is the usual way of turning a two-variable monomial into a bihomogeneous monomial of degree (k, ℓ) (remember that $\deg(x_1) = \deg(x_2) = (1, 0)$ and $\deg(x_3) = \deg(x_4) = (0, 1)$). Thus monomials of degree (k, ℓ) correspond to lattice points in the rectangle P_D . ◇

Example 5.4.4. The fan for $\text{Bl}_0(\mathbb{C}^2)$ is shown in Example 5.1.15, and its total coordinate ring $S = \mathbb{C}[t, x, y]$ is described in Example 5.2.3. If we pick $D = 0$, then the polyhedron $P_D \subset \mathbb{R}^2$ is defined by the inequalities

$$\langle m, u_i \rangle \geq 0, \quad i = 0, 1, 2.$$

Since u_1, u_2 form a basis of $N = \mathbb{Z}^2$ and $u_0 = u_1 + u_2$, P_D is the first quadrant in \mathbb{R}^2 . Given $m = (a, b) \in P_D \cap \mathbb{Z}^2$, the monomial $t_1^a t_2^b$ homogenizes to

$$t^{\langle m, u_0 \rangle} x^{\langle m, u_1 \rangle} y^{\langle m, u_2 \rangle} = t^{a+b} x^a y^b = (tx)^a (ty)^b.$$

where the ray generators u_0, u_1, u_2 correspond to the variables t, x, y .

For example, the singular cubic $t_1^3 - t_2^2 = 0$ homogenizes to $(tx)^3 - (ty)^2 = 0$, which is the equation encountered in Example 5.2.11 when resolving the singularity of this curve. \diamond

One thing to keep in mind when doing toric homogenization is that characters χ^m (in general) or Laurent monomials t^m (in specific examples) are intrinsically defined on the torus T_N or $(\mathbb{C}^*)^n$. The homogenization process produces a “global object” $x^{\langle m, D \rangle}$ relative to a divisor D that lives in the total coordinate ring or, via Proposition 5.4.1, in the global sections of $\mathcal{O}_{X_\Sigma}(D)$.

We next study the isomorphisms $S_\alpha \simeq \Gamma(X_\Sigma, \mathcal{O}_{X_\Sigma}(D))$ from Proposition 5.4.1. We will see that they are compatible with linear equivalence and multiplication.

First suppose that D and E are linearly equivalent torus-invariant divisors. This means that $D = E + \text{div}(\chi^m)$ for some $m \in M$. Proposition 4.0.29 implies that $f \mapsto f\chi^m$ induces an isomorphism

$$(5.4.1) \quad \Gamma(X_\Sigma, \mathcal{O}_{X_\Sigma}(D)) \simeq \Gamma(X_\Sigma, \mathcal{O}_{X_\Sigma}(E)).$$

Turning to the associated polyhedra, we proved $P_E = P_D + m$ in Exercise 4.3.2. An easy calculation shows that if $m' \in P_D$, then

$$x^{\langle m', D \rangle} = x^{\langle m' + m, E \rangle}$$

(Exercise 5.4.1). Hence (5.4.1) fits into a commutative diagram of isomorphisms

$$(5.4.2) \quad \begin{array}{ccc} \Gamma(X_\Sigma, \mathcal{O}_{X_\Sigma}(D)) & \xrightarrow{\sim} & \Gamma(X_\Sigma, \mathcal{O}_{X_\Sigma}(E)) \\ & \searrow \sim & \swarrow \sim \\ & S_\alpha & \end{array}$$

Here, $\alpha = [D] = [E] \in \text{Cl}(X_\Sigma)$ and the “diagonal” maps are the isomorphisms from Proposition 5.4.1. You will verify these claims in Exercise 5.4.1.

It follows that S_α gives a “canonical model” for $\Gamma(X_\Sigma, \mathcal{O}_{X_\Sigma}(D))$, since the latter depends on the particular choice of divisor D in the class α . It is also possible to give a “canonical model” for the polyhedron P_D (Exercise 5.4.2).

Next consider multiplication. Let D and E be torus-invariant divisors on X_Σ and set $\alpha = [D]$, $\beta = [E]$ in $\text{Cl}(X_\Sigma)$. Then $f \otimes g \mapsto fg$ induces a \mathbb{C} -linear map

$$\Gamma(X_\Sigma, \mathcal{O}_{X_\Sigma}(D)) \otimes_{\mathbb{C}} \Gamma(X_\Sigma, \mathcal{O}_{X_\Sigma}(E)) \longrightarrow \Gamma(X_\Sigma, \mathcal{O}_{X_\Sigma}(D + E))$$

such that the isomorphisms of Proposition 5.4.1 give a commutative diagram

$$(5.4.3) \quad \begin{array}{ccc} \Gamma(X_\Sigma, \mathcal{O}_{X_\Sigma}(D)) \otimes_{\mathbb{C}} \Gamma(X_\Sigma, \mathcal{O}_{X_\Sigma}(E)) & \longrightarrow & \Gamma(X_\Sigma, \mathcal{O}_{X_\Sigma}(D+E)) \\ \downarrow & & \downarrow \\ S_\alpha \otimes_{\mathbb{C}} S_\beta & \longrightarrow & S_{\alpha+\beta} \end{array}$$

where the bottom map is multiplication in the total coordinate ring (Exercise 5.4.3). Thus homogenization turns multiplication of sections into ordinary multiplication.

Polytopes. A full dimensional lattice polytope $P \subseteq M_{\mathbb{R}}$ gives a toric variety X_P . Recall that X_P can be constructed in two ways:

- As the toric variety X_{Σ_P} of the normal fan Σ_P of P (Chapter 3).
- As the projective toric variety $X_{(kP) \cap M}$ of the set of characters $(kP) \cap M$ for $k \gg 0$ (Chapter 2).

We will see that both descriptions relate nicely to homogenous coordinates and the total coordinate ring.

Given P as above, set $n = \dim P$ and let $P(i)$ denote the set of i -dimensional faces of P . Thus $P(0)$ consists of vertices and $P(n-1)$ consists of facets. The facet presentation of P given in equation (2.2.2) can be written as

$$(5.4.4) \quad P = \{m \in M_{\mathbb{R}} \mid \langle m, u_F \rangle \geq -a_F \text{ for all } F \in P(n-1)\}.$$

In terms of the normal fan Σ_P , we have bijections

$$\begin{aligned} P(0) &\longleftrightarrow \Sigma_P(n) && (\text{vertices} \longleftrightarrow \text{maximal cones}) \\ P(n-1) &\longleftrightarrow \Sigma_P(1) && (\text{facets} \longleftrightarrow \text{rays}). \end{aligned}$$

When dealing with polytopes we index everything by facets rather than rays. Thus each facet $F \in P(n-1)$ gives:

- The facet normal u_F , which is the ray generator of the corresponding cone.
- The torus-invariant prime divisor $D_F \subseteq X_P$.
- The variable x_F in the total coordinate ring S . We call x_F a *facet variable*.

We also have the divisor

$$D_P = \sum_F a_F D_F$$

from (4.2.5). The polytope P_{D_P} of this divisor is the polytope P we began with (Exercise 4.3.1). Hence, if we set $\alpha = [D_P] \in \text{Cl}(X_P)$, then we get isomorphisms

$$S_\alpha \simeq \Gamma(X_P, \mathcal{O}_{X_P}(D_P)) \simeq \bigoplus_{m \in P \cap M} \mathbb{C} \cdot \chi^m.$$

In this situation, we write the D_P -homogenization of χ^m as

$$x^{\langle m, P \rangle} = \prod_F x_F^{\langle m, u_F \rangle + a_F}.$$

We call $x^{(m,P)}$ a P -monomial.

The exponent of the variable x_F in $x^{(m,P)}$ gives the *lattice distance* from m to the facet F . To see this, note that F lies in the supporting hyperplane defined by $\langle m, u_F \rangle + a_F = 0$. If the exponent of x_F is $a \geq 0$, then to get from the supporting hyperplane to m , we must pass through the a parallel hyperplanes, namely $\langle m, u_F \rangle + a_F = j$ for $j = 1, \dots, a$. Here is an example.

Example 5.4.5. Consider the toric variety X_P of the polygon $P \subset \mathbb{R}^2$ with vertices

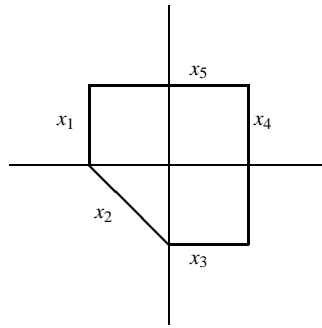

Figure 2. A polygon with facets labeled by variables

$(1, 1), (-1, 1), (-1, 0), (0, -1), (1, -1)$, shown in Figure 2. In terms of (5.4.4), we have $a_1 = \dots = a_5 = 1$, where the indices correspond to the facet variables x_1, \dots, x_5 indicated in Figure 2. The 8 points of $P \cap \mathbb{Z}^2$ give P -monomials

$$\begin{array}{ccc} x_2 x_3^2 x_4^2 & x_1 x_2^2 x_3^2 x_4 & x_1^2 x_2^3 x_3^2 \\ x_3 x_4^2 x_5 & x_1 x_2 x_3 x_4 x_5 & x_1^2 x_2^2 x_3 x_5 \\ & x_1 x_4 x_5^2 & x_1^2 x_2 x_5^2, \end{array}$$

where the position of each P -monomial $x^{(m,P)}$ corresponds to the position of the lattice point $m \in P \cap \mathbb{Z}^2$. The exponents are easy to understand if you think in terms of lattice distances to facets. \diamond

The lattice-distance interpretation of the exponents in $x^{(m,P)}$ shows that lattice points in the interior $\text{int}(P)$ of P correspond to those P -monomials divisible by $\prod_F x_F$. For example, the only P -monomial in Example 5.4.5 divisible by $x_1 \cdots x_5$ corresponds to the unique interior lattice point.

We next relate the constructions of toric varieties given in Chapter 2 and in §5.1. In Chapter 2, we wrote the lattice points of P as $P \cap M = \{m_1, \dots, m_s\}$ and considered the map

$$(5.4.5) \quad \Phi : T_N \longrightarrow \mathbb{P}^{s-1}, \quad t \longmapsto (\chi^{m_1}(t), \dots, \chi^{m_s}(t)).$$

The projective (possibly non-normal) toric variety $X_{P \cap M}$ is the Zariski closure of the image of Φ .

On the other hand, we have the quotient construction of X_P

$$X_P \simeq (\mathbb{C}^r \setminus Z(\Sigma_P)) // G,$$

where we write $\mathbb{C}^r = \mathbb{C}^{\Sigma_P(1)}$. Also, the exceptional set $Z(\Sigma_P)$ can be described in terms of the P -monomials coming from the vertices of the polytope.

Lemma 5.4.6. *The vertex monomials $x^{(v,P)}$, v a vertex of P , have the following properties:*

- (a) $\sqrt{\langle x^{(v,P)} \mid v \in P(0) \rangle} = B(\Sigma_P)$, where $B(\Sigma_P) = \langle x^{\hat{\sigma}} \mid \sigma \in \Sigma(n) \rangle$ is the irrelevant ideal of S .
- (b) $Z(\Sigma_P) = \mathbf{V}(x^{(v,P)} \mid v \in P(0))$.

Proof. We saw above that vertices $v \in P(0)$ correspond bijectively to cones $\sigma_v = \text{Cone}(u_F \mid v \in F) \in \Sigma_P(n)$. Then the lattice-distance interpretation of $x^{(v,P)}$ shows the facet variables x_F appearing in $x^{(v,P)}$ are precisely the variables appearing in $x^{\hat{\sigma}_v}$. This implies part (a), and part (b) follows immediately. \square

If we set $\alpha = [D_P]$ as above, then the P -monomials $x^{(m_i,P)}$, $i = 1, \dots, s$, form a basis of S_α and give a map

$$(5.4.6) \quad \Psi : \mathbb{C}^r \setminus Z(\Sigma_P) \longrightarrow \mathbb{P}^{s-1} \quad p \longmapsto (p^{(m_1,P)}, \dots, p^{(m_s,P)}),$$

where $p^{(m_i,P)}$ is the evaluation of the monomial $x^{(m_i,P)}$ at the point $p \in \mathbb{C}^r \setminus Z(\Sigma_P)$. This map is well-defined since for each $p \in \mathbb{C}^r \setminus Z(\Sigma_P)$, Lemma 5.4.6 implies that at least one P -monomial (in fact, at least one vertex monomial) must be nonzero.

The maps (5.4.5) and (5.4.6) fit into a diagram

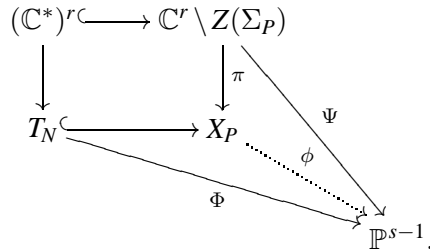

Here, the map $(\mathbb{C}^*)^r \rightarrow T_N$ is described in (5.1.2) and $\pi : \mathbb{C}^r \setminus Z(\Sigma_P) \rightarrow X_P$ is the quotient map. This diagram has the following properties.

Proposition 5.4.7. *There is a morphism $\phi : X_P \rightarrow \mathbb{P}^{s-1}$ represented by the dotted arrow in the above diagram that makes the entire diagram commute. Furthermore, the image of ϕ is precisely the projective toric variety $X_{P \cap M}$.*

Proof. When we regard the x_F as characters on $(\mathbb{C}^*)^r = (\mathbb{C}^*)^{\Sigma_P(1)}$, the exact sequence (5.1.1) tells us that

$$(5.4.7) \quad \chi^m = \prod_F x_F^{\langle m, u_F \rangle}.$$

Multiplying each side by $\prod_F x_F^{a_F}$, we obtain

$$\left(\prod_F x_F^{a_F} \right) \chi^m = x^{\langle m, D \rangle}.$$

If we let $m = m_i$, $i = 1, \dots, s$ and apply this to a point in $p \in (\mathbb{C}^*)^r$, we see that $\Phi(p)$ and $\Psi(p)$ give the same point in projective space since $\prod_F p_F^{a_F}$ times vector for $\Psi(p)$ equals the vector for $\Phi(p)$. It follows that, ignoring ϕ for the moment, the rest of the above diagram commutes.

We next show that Ψ is constant on G -orbits. This holds since P -monomials are homogeneous of the same degree. In more detail, fix points $t = (t_F) \in G$, $p = (p_F) \in \mathbb{C}^r \setminus Z(\Sigma_P)$ and a P -monomial $x^{\langle m, D \rangle} = \prod_F x_F^{\langle m, u_F \rangle + a_F}$. Then evaluating $x^{\langle m, D \rangle}$ at $t \cdot p$ gives

$$\begin{aligned} (t \cdot p)^{\langle m, D \rangle} &= \prod_F (t_F p_F)^{\langle m, u_F \rangle + a_F} \\ &= \left(\prod_F t_F^{\langle m, u_F \rangle} \right) \left(\prod_F p_F^{a_F} \right) p^{\langle m, D \rangle} = \left(\prod_F t_F^{a_F} \right) p^{\langle m, D \rangle}, \end{aligned}$$

where the last equality follows from the description of G given in Lemma 5.1.1. Arguing as in the previous paragraph, it follows that $\Psi(t \cdot p)$ and $\Psi(p)$ give the same point in \mathbb{P}^{s-1} . This proves the existence of ϕ since π is a good categorical quotient, and this choice of ϕ makes the entire diagram commute.

The final step is to show that the image of $\phi : X_P \rightarrow \mathbb{P}^{s-1}$ is the Zariski closure $X_{P \cap M}$ of the image of $\Phi : T_N \rightarrow \mathbb{P}^{s-1}$. First observe that

$$\phi(X_P) = \phi(\overline{T_N}) \subseteq \overline{\phi(T_N)} = \overline{\Phi(T_N)} = X_{P \cap M}$$

since ϕ is continuous in the Zariski topology and $\phi|_{T_N} = \Phi$ by commutivity of the diagram. However, $\phi(X_P)$ is Zariski closed in \mathbb{P}^{s-1} since X_P is projective. You will give two proofs of this in Exercise 5.4.4, one topological (using constructible sets and compactness) and one algebraic (using completeness and properness). Once we know that $\phi(X_P)$ is Zariski closed, $\Phi(T_N) \subseteq \phi(X_P)$ implies

$$X_{P \cap M} = \overline{\Phi(T_N)} \subseteq \phi(X_P),$$

and $\phi(X_P) = X_{P \cap M}$ follows. \square

In Chapter 2, we used the map Φ —constructed from characters—to parametrize a big chunk of the projective toric variety $X_{P \cap M}$. In contrast, Proposition 5.4.7 uses the map Ψ —constructed from P -monomials—to parametrize *all* of $X_{P \cap M}$.

If the lattice polytope P is very ample, then the results of Chapter 2 imply that $X_{P \cap M}$ is the toric variety X_P . So in the very ample case, the P -monomials give an explicit construction of the quotient $(\mathbb{C}^r \setminus Z(\Sigma_P)) // G$ by mapping $\mathbb{C}^r \setminus Z(\Sigma_P)$ to projective space via the P -monomials. It follows that we have two ways to take the quotient of \mathbb{C}^r by G :

- At the beginning of the chapter, we took G -invariant polynomials—elements of S_0 —to construct an affine quotient.
- Here, we use P -monomials—elements of S_α —to construct a projective quotient, after removing a set $Z(\Sigma_P)$ of “bad” points.

The P -monomials are not G -invariant but instead transform the *same* way under G . This is why we map to projective space rather than affine space. We will explore these ideas further in Chapter 14 when we discuss *geometric invariant theory*.

When P is very ample, we have a projective embedding $X_P \subseteq \mathbb{P}^{s-1}$ given by the P -monomials in S_α . If y_1, \dots, y_s are homogeneous coordinates of \mathbb{P}^{s-1} , then the *homogeneous coordinate ring* of X_P is

$$\mathbb{C}[X_P] = \mathbb{C}[y_1, \dots, y_s]/\mathbf{I}(X_P)$$

as in §2.0. We also have the affine cone $\widehat{X}_P \subseteq \mathbb{C}^r$ of X_P , and $\mathbb{C}[X_P]$ is the ordinary coordinate ring of \widehat{X}_P , i.e.,

$$\mathbb{C}[X_P] = \mathbb{C}[\widehat{X}_P].$$

Recall that $\mathbb{C}[X_P]$ is an \mathbb{N} -graded ring since $\mathbf{I}(X_P)$ is a homogeneous ideal.

Another \mathbb{N} -graded ring is $\bigoplus_{k=0}^{\infty} S_{k\alpha}$. This relates to $\mathbb{C}[X_P]$ as follows.

Theorem 5.4.8. *Let P be a very ample lattice polytope with $\alpha = [D_P] \in \text{Cl}(X_P)$. Then:*

- (a) $\bigoplus_{k=0}^{\infty} S_{k\alpha}$ is normal.
- (b) There is a natural inclusion $\mathbb{C}[X_P] \subseteq \bigoplus_{k=0}^{\infty} S_{k\alpha}$ such that $\bigoplus_{k=0}^{\infty} S_{k\alpha}$ is the normalization of $\mathbb{C}[X_P]$.
- (c) The following are equivalent:
 - (1) $X_P \subseteq \mathbb{P}^{s-1}$ is projectively normal.
 - (2) P is normal.
 - (3) $\bigoplus_{k=0}^{\infty} S_{k\alpha} = \mathbb{C}[X_P]$.
 - (4) $\bigoplus_{k=0}^{\infty} S_{k\alpha}$ is generated as a \mathbb{C} -algebra by its elements of degree 1.

Proof. Consider the cone

$$C(P) = \text{Cone}(P \times \{1\}) \subseteq M_{\mathbb{R}} \times \mathbb{R}.$$

This cone is pictured in Figure 4 of §2.2. Recall that kP is the “slice” of $C(P)$ at height k . Since the divisor D_{kP} associated to kP is kD_P , homogenization with respect to kP induces an isomorphism

$$S_{k\alpha} \simeq \Gamma(X_P, \mathcal{O}_{X_P}(kD_P)) \simeq \bigoplus_{m \in (kP) \cap M} \mathbb{C} \cdot \chi^m.$$

Now consider the dual cone $\sigma_P = C(P)^\vee \subseteq N_{\mathbb{R}} \times \mathbb{R}$. The semigroup algebra $\mathbb{C}[C(P) \cap (M \times \mathbb{Z})]$ is the coordinate ring of the affine toric variety U_{σ_P} . Given $(m, k) \in C(P) \cap (M \times \mathbb{Z})$, we write the corresponding character as $\chi^m t^k$.

The algebra $\mathbb{C}[C(P) \cap (M \times \mathbb{Z})]$ is graded using the last coordinate, the “height.” Since $(m, k) \in C(P) \cap (M \times \mathbb{Z})$ if and only if $m \in kP$ (this is the “slice” observation made above), we have

$$\mathbb{C}[C(P) \cap (M \times \mathbb{Z})]_k = \bigoplus_{m \in (kP) \cap M} \mathbb{C} \cdot \chi^m t^k.$$

Using (5.4.3), we obtain a graded \mathbb{C} -algebra isomorphism

$$\bigoplus_{k=0}^{\infty} S_{k\alpha} \simeq \mathbb{C}[C(P) \cap (M \times \mathbb{Z})].$$

This proves that $\bigoplus_{k=0}^{\infty} S_{k\alpha}$ is normal.

We next claim that U_{σ_P} is the normalization of the affine cone \widehat{X}_P . For this, we let $\mathcal{A} = (P \cap M) \times \{1\} \subseteq M \times \mathbb{Z}$. As noted in the proof of Theorem 2.4.1, the affine cone of $X_P = X_{P \cap M}$ is $\widehat{X}_P = Y_{\mathcal{A}}$. Since P is very ample, one easily checks that \mathcal{A} generates $M \times \mathbb{Z}$, i.e., $\mathbb{Z}\mathcal{A} = M \times \mathbb{Z}$ (Exercise 5.4.5). It is also clear that \mathcal{A} generates the cone $C(P) = \sigma_P^\vee$. Hence U_{σ_P} is the normalization of \widehat{X}_P by Proposition 1.3.8. This immediately implies part (b).

For part (c), we observe that (1) \Leftrightarrow (2) follows from Theorem 2.4.1, and (1) \Leftrightarrow (3) follows from parts (a) and (b) since the projective normality of $X_P \subseteq \mathbb{P}^{s-1}$ is equivalent to the normality of $\mathbb{C}[X_P]$. Also (3) \Rightarrow (4) is obvious since $\mathbb{C}[X_P]$ is generated by the images of y_1, \dots, y_s , which have degree 1. Finally, you will show in Exercise 5.4.6 that (4) \Rightarrow (2), completing the proof. \square

Further Examples. We begin with an example of that illustrates how there can be many different polytopes that give the same toric variety.

Example 5.4.9. The toric surface in Example 5.4.5 was defined using the polygon shown in Figure 2. In Figure 3 we see four polygons $A, A \cup B, A \cup C, A \cup D$, all

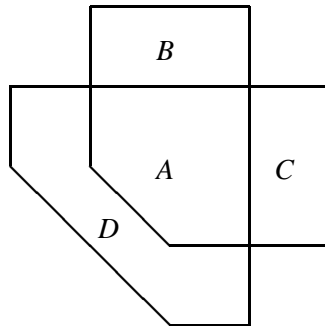

Figure 3. Four polygons $A, A \cup B, A \cup C, A \cup D$ with the same normal fan

of which have the same normal fan and hence give the same toric variety. Since

we are in dimension 2, these polygons are very ample (in fact, normal), so that Theorem 5.4.8 applies.

These four polygons give four different projective embeddings, each of which has its own coordinate ring as a projective variety. By Theorem 5.4.8, these coordinate rings all live in the total coordinate ring S . This explains the “total” in “total coordinate ring.” \diamond

Our next example involves torsion in the grading of the total coordinate ring.

Example 5.4.10. The fan Σ for \mathbb{P}^4 has ray generators $u_0 = -\sum_{i=1}^4 e_i$ and $u_i = e_i$ for $i = 1, \dots, 4$ in $N = \mathbb{Z}^4$ and is the normal fan of the standard simplex $\Delta_4 \subseteq \mathbb{R}^4$. Another polytope with the same normal fan is

$$P = 5\Delta_4 - (1, 1, 1, 1) \subseteq M_{\mathbb{R}} = \mathbb{R}^4,$$

so that $X_P = \mathbb{P}^4$. We saw that P is reflexive in Example 2.4.5. One checks that $D_P = D_0 + \dots + D_4$ has degree $5 \in \mathbb{Z} \simeq \text{Cl}(\mathbb{P}^4)$. Since P is a translate of $5\Delta_4$, (5.4.2) implies that the P -monomials for $m \in P \cap \mathbb{Z}^4$ coincide with the homogenizations coming from $5\Delta_4$, which are homogeneous polynomials of degree 5 in $S = \mathbb{C}[x_0, \dots, x_4]$.

Since P is reflexive, its dual P° is also a lattice polytope. Furthermore,

$$P^\circ = \text{Conv}(u_0, \dots, u_4) \subseteq N_{\mathbb{R}} = \mathbb{R}^4$$

since the ray generators of the normal fan of P° are the *vertices* of P by duality for reflexive polytopes (be sure you understand this—Exercise 5.4.7). The vertices of P are

$$(5.4.8) \quad \begin{aligned} v_0 &= (-1, -1, -1, -1), \quad v_1 = (4, -1, -1, -1), \quad v_2 = (-1, 4, -1, -1) \\ v_3 &= (-1, -1, 4, -1), \quad v_4 = (-1, -1, -1, 4). \end{aligned}$$

The v_i generate a sublattice $M_1 \subseteq M = \mathbb{Z}^4$. In Exercise 5.4.7 you will show that the map $M \rightarrow \mathbb{Z}^5$ defined by

$$m \in M \mapsto (\langle m, u_0 \rangle, \dots, \langle m, u_4 \rangle) \in \mathbb{Z}^5$$

induces an isomorphism

$$(5.4.9) \quad M/M_1 \simeq \{(a_0, a_1, a_2, a_3, a_4) \in (\mathbb{Z}/5\mathbb{Z})^5 : \sum_{i=0}^4 a_i = 0\} / (\mathbb{Z}/5\mathbb{Z})$$

where $\mathbb{Z}/5\mathbb{Z} \subseteq (\mathbb{Z}/55\mathbb{Z})^5$ is the diagonal subgroup. Then $M/M_1 \simeq (\mathbb{Z}/5\mathbb{Z})^3$, so that M_1 is a lattice of index 125 in M .

The dual toric variety X_{P° is determined by the normal fan Σ° of P° . The ray generators of Σ° are the vectors v_0, \dots, v_4 from (5.4.8). The only possible complete fan in \mathbb{R}^4 with these ray generators is the fan whose cones are generated by all proper subsets of $\{v_0, \dots, v_4\}$. Since $v_0 + \dots + v_4 = 0$ and the v_i generate M_1 ,

the toric variety of Σ° relative to M_1 is \mathbb{P}^4 , i.e., $X_{\Sigma^\circ, M_1} = \mathbb{P}^4$. (Remember that Σ° is a fan in $(M_1)_{\mathbb{R}} = M_{\mathbb{R}}$.) Since $M_1 \subseteq M$ has index 125, Proposition 3.3.7 implies

$$X_{P^\circ} = X_{P^\circ, M} \simeq X_{P^\circ, M_1} / (M/M_1) = \mathbb{P}^4 / (M/M_1).$$

Hence the dual toric variety X_{P° is the quotient of \mathbb{P}^4 by a group of order 125.

The total coordinate ring S° is the polynomial ring $\mathbb{C}[y_0, \dots, y_4]$, graded by $\text{Cl}(X_{P^\circ})$. The notation is challenging, since by duality N is the character lattice of the torus of X_{P° . Thus (5.1.1) becomes the short exact sequence

$$0 \longrightarrow N \longrightarrow \mathbb{Z}^5 \longrightarrow \text{Cl}(X_{P^\circ}) \longrightarrow 0,$$

where $N \rightarrow \mathbb{Z}^5$ is $u \mapsto (\langle v_0, u \rangle, \dots, \langle v_4, u \rangle)$. If we let $N_1 = \text{Hom}_{\mathbb{Z}}(M_1, \mathbb{Z})$, then $M_1 \subseteq M$ dualizes to $N \subseteq N_1$ of index 125. Now consider the diagram

$$\begin{array}{ccccccc} & & 0 & & & & \\ & & \downarrow & & & & \\ 0 & \longrightarrow & N & \longrightarrow & \mathbb{Z}^5 & \longrightarrow & \text{Cl}(X_{P^\circ}) \longrightarrow 0 \\ & & \downarrow & & \downarrow & & \downarrow \\ 0 & \longrightarrow & N_1 & \longrightarrow & \mathbb{Z}^5 & \longrightarrow & \mathbb{Z} \longrightarrow 0 \\ & & \downarrow & & & & \\ & & N_1/N & & & & \\ & & \downarrow & & & & \\ & & 0 & & & & \end{array}$$

with exact rows and columns. In the middle row, we use $\text{Cl}(X_{\Sigma^\circ, M_1}) = \text{Cl}(\mathbb{P}^4) = \mathbb{Z}$. By the snake lemma, we obtain the exact sequence

$$0 \longrightarrow N_1/N \longrightarrow \text{Cl}(X_{P^\circ}) \longrightarrow \mathbb{Z} \longrightarrow 0,$$

so $\text{Cl}(X_{P^\circ}) \simeq \mathbb{Z} \oplus N/N_1$. Thus the class group has torsion.

The polytope P° has only six lattice points in N : the vertices u_0, \dots, u_4 and the origin (Exercise 5.4.7). When we homogenize these, we get six P° -monomials

$$y^{\langle 0, D \rangle} = \prod_{j=0}^4 y_j^{\langle v_j, 0 \rangle + 1} = y_0 \cdots y_4$$

$$y^{\langle u_i, D \rangle} = \prod_{j=0}^4 y_j^{\langle v_j, u_i \rangle + 1} = y_i^5, \quad i = 0, \dots, 4$$

since $\langle v_j, u_i \rangle = 5\delta_{ij} - 1$ (Exercise 5.4.7). ◇

The equation

$$c_0 y_0^5 + \cdots + c_4 y_4^5 + c_5 y_0 \cdots y_4 = 0$$

defines a hypersurface $Y \subseteq X_{P^\circ}$ since it is built from P° -monomials. If we want an irreducible hypersurface, we must have $c_0, \dots, c_4 \neq 0$, in which case Y is isomorphic (via the torus action) to a hypersurface of the form

$$y_0^5 + \dots + y_4^5 + \lambda y_0 \cdots y_4 = 0.$$

This is the *quintic mirror family*, which played a crucial role in the development of mirror symmetry. See [34] for an introduction to this astonishing subject.

Exercises for §5.4.

5.4.1. Let D, E be linearly equivalent torus-invariant divisors with $D = \text{div}(\chi^m) + E$.

- (a) If $m' \in P_D \cap M$, then prove that $x^{\langle m', D \rangle} = x^{\langle m' + m, E \rangle}$.
- (b) Prove (5.4.2).

5.4.2. Fix a torus-invariant divisor $D = \sum_\rho a_\rho D_\rho$ and consider its associated polyhedron $P_D = \{m \in M_\mathbb{R} \mid \langle m, u_\rho \rangle \geq -a_\rho \text{ for all } \rho\}$. Define

$$\phi_D : M_\mathbb{R} \longrightarrow \mathbb{R}^{\Sigma(1)}$$

by $\phi_D(m) = (\langle m, u_\rho \rangle + a_\rho) \in \mathbb{R}^{\Sigma(1)}$.

- (a) Prove that ϕ_D embeds $M_\mathbb{R}$ as an affine subspace of $\mathbb{R}^{\Sigma(1)}$. Hint: Remember that X_Σ has no torus factors.
- (b) Prove that ϕ_D induces a bijection

$$\phi_D|_{P_D} : P_D \simeq \phi_D(M_\mathbb{R}) \cap \mathbb{R}_{\geq 0}^{\Sigma(1)}.$$

This realizes P_D as the polyhedron obtained by intersecting the positive orthant $\mathbb{R}_{\geq 0}^{\Sigma(1)}$ of $\mathbb{R}^{\Sigma(1)}$ with an affine subspace.

- (c) Let $D = \text{div}(\chi^m) + E$. Prove that $\phi_D(P_D) = \phi_E(P_E)$. Thus the polyhedron in $\mathbb{R}^{\Sigma(1)}$ constructed in part (b) depends only on the divisor class of D . This is the “canonical model” of P_D .

5.4.3. Prove that the diagram (5.4.3) is commutative.

5.4.4. The proof of Proposition 5.4.7 claimed that the image of $\phi : X_P \rightarrow \mathbb{P}^{s-1}$ was Zariski closed. This follows from the general fact that if $\phi : X \rightarrow Y$ is a morphism of varieties and X is complete, then $\phi(X)$ is Zariski closed in Y . You will prove this two ways.

- (a) Give a topological proof that uses constructible sets and compactness. Hint: Remember that projective space is compact.
- (b) Give an algebraic proof that uses completeness and properness from §3.4. Hint: Show that $X \times Y \rightarrow Y$ is proper and use the graph of ϕ .

5.4.5. Let $P \subseteq M_\mathbb{R}$ be a very ample lattice polytope and let $\mathcal{A} = (P \cap M) \times \{1\} \subseteq M \times \mathbb{Z}$. Prove that $\mathbb{Z}\mathcal{A} = M \times \mathbb{Z}$. Hint: First show that $\mathbb{Z}'\mathcal{A} = M \times \{0\}$, where $\mathbb{Z}'\mathcal{A}$ is defined in the discussion preceding Proposition 2.1.6.

5.4.6. Prove of (4) \Rightarrow (2) in part (c) of Theorem 5.4.8. Hint: (4) implies that the map $S_\alpha \otimes_{\mathbb{C}} S_{k\alpha} \rightarrow S_{(k+1)\alpha}$ is onto for all $k \geq 0$.

5.4.7. This exercise is concerned with Example 5.4.10.

- (a) Prove that if $P \subseteq \mathbb{R}^n$ is reflexive, then the vertices of P are the ray generators of the normal fan of P° .
- (b) Prove (5.4.9).
- (c) Prove $\langle v_j, u_i \rangle = 5\delta_{ij} - 1$, where v_j, u_i are defined in Example 5.4.10.
- (d) Let $G = \text{Hom}_{\mathbb{Z}}(\text{Cl}(X_{P^\circ}), \mathbb{C}^*) \subseteq (\mathbb{C}^*)^5$. Use Proposition 1.3.18 to prove
- $$G = \{(\lambda\zeta_0, \dots, \lambda\zeta_4) \mid \lambda \in \mathbb{C}^*, \zeta_i \in \mu_5, \zeta_0 \cdots \zeta_4 = 1\} \simeq \mathbb{C}^* \oplus M/M_1.$$
- (e) Use part (e) and the quotient construction of X_{P° to give another proof that $X_{P^\circ} = \mathbb{P}^4/(M/M_1)$. Also give an explicit description of the action of M/M_1 on \mathbb{P}^4 .

5.4.8. This exercise will give another way to think about homogenization. Let e_1, \dots, e_n be a basis of M , so that $t_i = \chi^{e_i}$, $i = 1, \dots, n$, are coordinates for the torus T_N .

- (a) Adapt the proof of (5.4.7) to show that $t_i = \prod_{\rho} x_{\rho}^{\langle e_i, u_{\rho} \rangle}$ when we think of the x_{ρ} as characters on $(\mathbb{C}^*)^{\Sigma(1)}$.
- (b) Given $m \in P_D \cap M$, part (a) tells us that the Laurent monomial t^m can be regarded as a Laurent monomial in the x_{ρ} . Show that we can “clear denominators” by multiplying by $\prod_{\rho} x_{\rho}^{a_{\rho}}$ to obtain a monomial in the polynomial ring $S = \mathbb{C}[x_{\rho} \mid \rho \in \Sigma(1)]$.
- (c) Show that this monomial obtained in part (b) is the homogenization $x^{\langle m, D \rangle}$.

5.4.9. Consider the toric variety X_P of Example 5.4.5.

- (a) Compute $\text{Cl}(X_P)$ and find the classes of the four polygons appearing in Figure 3.
- (b) Show that X_P is the blowup of $\mathbb{P}^1 \times \mathbb{P}^1$ at one point.

5.4.10. Consider the reflexive polytope $P = 4\Delta_3 - (1, 1, 1) \subseteq \mathbb{R}^3$. Work out the analog of Example 5.4.10 for P .

5.4.11. Fix an integer $a \geq 1$ and consider the 3-simplex $P = \text{Conv}(0, ae_1, ae_2, e_3) \subseteq \mathbb{R}^3$. In Exercise 2.2.13, we claimed that the toric variety of P is the weighted projective space $\mathbb{P}(1, 1, 1, a)$. Prove this.

Line Bundles on Toric Varieties

§6.0. Background: Sheaves and Line Bundles

Sheaves of \mathcal{O}_X -modules on a variety X were introduced in §4.0. Recall that for an affine variety $V = \text{Spec}(R)$, an R -module M gives a sheaf \tilde{M} on V such that $\tilde{M}(V_f) = M_f$ for all $f \neq 0$ in R . Globalizing this leads to quasicohherent sheaves on X . These include coherent sheaves, which locally come from finitely generated modules. In this section we develop the language of sheaf theory and discuss vector bundles and line bundles.

The Stalk of a Sheaf at a Point. Since sheaves are local in nature, we need a method for inspecting a sheaf at a point $p \in X$. This is provided by the notion of *direct limit* over a *directed set*.

Definition 6.0.1. A partially ordered set (I, \preceq) is a *directed set* if

$$\text{for all } i, j \in I, \text{ there exists } k \in I \text{ such that } i \preceq k \text{ and } j \preceq k.$$

If $\{R_i\}$ is a family of rings indexed by a directed set (I, \preceq) such that whenever $i \preceq j$ there is a homomorphism

$$\mu_{ji} : R_i \longrightarrow R_j$$

satisfying $\mu_{ii} = 1_{R_i}$ and $\mu_{ij} \circ \mu_{jk} = \mu_{ik}$, then the R_i form a *directed system*. Let S be the submodule of $\bigoplus_{i \in I} R_i$ generated by the relations $r_i - \mu_{ji}(r_i)$, for $r_i \in R_i$ and $i \preceq j$. Then the *direct limit* is defined as

$$\lim_{\substack{\longrightarrow \\ i \in I}} R_i = \left(\bigoplus_{i \in I} R_i \right) / S.$$

For simplicity, we often write the direct limit as $\varinjlim R_i$. Note also that references such as [3] write μ_{ij} instead of μ_{ji} .

For every $i \in I$, there is a natural map $R_i \rightarrow \varinjlim R_i$ such that whenever $i \preceq j$, the elements $r \in R_i$ and $\mu_{ji}(r) \in R_j$ have the same image in $\varinjlim R_i$. More generally, two elements $r_i \in R_i$ and $r_j \in R_j$ are identified in $\varinjlim R_i$ if there is a diagram

$$\begin{array}{ccc} R_i & \xrightarrow{\mu_{ki}} & R_k \\ & \searrow & \nearrow \\ R_j & \xrightarrow{\mu_{kj}} & R_k \end{array}$$

such that $\mu_{ki}(r_i) = \mu_{kj}(r_j)$.

Example 6.0.2. Given $p \in X$, the definition of sheaf shows that the rings $\mathcal{O}_X(U)$, indexed by neighborhoods U of p , form a directed system under inclusion, and in this case, the direct limit is the local ring $\mathcal{O}_{X,p}$. For a quasicoherent sheaf of \mathcal{O}_X -modules, take an affine open subset $V = \text{Spec}(R)$ containing p so that $\mathcal{F}(V) = M$, where M is an R -module. If $\mathfrak{m}_p = \mathbf{I}(p) \subseteq R$ is the corresponding maximal ideal, then $\mathcal{O}_{X,p}$ is the localization $R_{\mathfrak{m}_p}$ and

$$\varinjlim_{p \in U} \mathcal{F}(U) = M_{\mathfrak{m}_p},$$

where $M_{\mathfrak{m}_p}$ is the localization of M at the maximal ideal \mathfrak{m}_p . \diamond

The term *sheaf* has agrarian origins: farmers harvesting their wheat tied a rope around a big bundle, and left it standing to dry. Think of the footprint of the bundle as an open set, so that increasingly smaller neighborhoods around a point on the ground pick out smaller and smaller bits of the bundle, narrowing to a single stalk.

Definition 6.0.3. The *stalk* of a sheaf \mathcal{F} at a point $p \in X$ is $\mathcal{F}_p = \varinjlim_{p \in U} \mathcal{F}(U)$.

Injective and Surjective. A homomorphism $\phi : \mathcal{F} \rightarrow \mathcal{G}$ of \mathcal{O}_X -modules was defined in §4.0. We can also define what it means for ϕ to be injective or surjective. The definition is a bit unexpected, since we need to take into account the fact that sheaves are built to convey local data.

Definition 6.0.4. A sheaf homomorphism

$$\phi : \mathcal{F} \longrightarrow \mathcal{G}$$

is *injective* if for any point $p \in X$ and open subset $U \subseteq X$ containing p , there exists an open subset $V \subseteq U$ containing p , with ϕ_V injective. Also, ϕ is *surjective* if for any point p and open subset U containing p and any $g \in \mathcal{G}(U)$, there is an open subset $V \subseteq U$ containing p and $f \in \mathcal{F}(V)$ such that $\phi_V(f) = \rho_{U,V}(g)$.

In Exercise 6.0.1 you will prove that for a sheaf homomorphism $\phi : \mathcal{F} \rightarrow \mathcal{G}$,

$$U \longmapsto \ker(\phi_U : \mathcal{F}(U) \rightarrow \mathcal{G}(U))$$

defines a sheaf denoted $\ker(\phi)$. You will also show that ϕ is injective exactly when the “naive” idea works, i.e., $\ker(\phi) = 0$. On the other hand, surjectivity of a sheaf homomorphism need not mean that the maps ϕ_U are surjective for all U . Here is an example.

Example 6.0.5. On $\mathbb{P}^1 = \mathbb{C} \cup \{\infty\}$, consider the Weil divisor $D = \{0\} \subseteq \mathbb{C} \subseteq \mathbb{P}^1$. If we write of $\mathbb{P}^1 = U_0 \cup U_1$ with $U_0 = \text{Spec}(\mathbb{C}[t])$ and $U_1 = \text{Spec}(\mathbb{C}[t^{-1}])$, then $\mathbb{C}(\mathbb{P}^1) = \mathbb{C}(t)$. Since

$$\Gamma(\mathbb{P}^1, \mathcal{O}_{\mathbb{P}^1}(D)) = \{f \in \mathbb{C}(t)^* \mid \text{div}(f) + D \geq 0\} \cup \{0\},$$

it follows easily that we have global sections

$$1, t^{-1} \in \Gamma(\mathbb{P}^1, \mathcal{O}_{\mathbb{P}^1}(D)).$$

For any $f \in \Gamma(\mathbb{P}^1, \mathcal{O}_{\mathbb{P}^1}(D))$, multiplication by f gives a sheaf homomorphism $\mathcal{O}_{\mathbb{P}^1}(-D) \rightarrow \mathcal{O}_{\mathbb{P}^1}$. Doing this for $1, t^{-1} \in \Gamma(\mathbb{P}^1, \mathcal{O}_{\mathbb{P}^1}(D))$ gives

$$\mathcal{O}_{\mathbb{P}^1}(-D) \oplus \mathcal{O}_{\mathbb{P}^1}(-D) \longrightarrow \mathcal{O}_{\mathbb{P}^1}.$$

(Direct sums of sheaves will be defined below.) In Exercise 6.0.2 you will check that this sheaf homomorphism is surjective. However, taking global sections gives

$$0 \oplus 0 = \Gamma(\mathbb{P}^1, \mathcal{O}_{\mathbb{P}^1}(-D)) \oplus \Gamma(\mathbb{P}^1, \mathcal{O}_{\mathbb{P}^1}(-D)) \longrightarrow \Gamma(\mathbb{P}^1, \mathcal{O}_{\mathbb{P}^1}) = \mathbb{C},$$

which is clearly not surjective. ◇

There is an additional point to make here. Given $\phi : \mathcal{F} \rightarrow \mathcal{G}$, the presheaf

$$U \longmapsto \text{im}(\phi_U : \mathcal{F}(U) \rightarrow \mathcal{G}(U))$$

need not be a sheaf. Fortunately, this can be rectified. Given a presheaf \mathcal{F} , there is an associated sheaf \mathcal{F}^+ , the *sheafification* of \mathcal{F} , which is defined by

$$\mathcal{F}^+(U) = \{f : U \rightarrow \prod_{p \in U} \mathcal{F}_p \mid \text{for all } p \in U, f(p) \in \mathcal{F}_p \text{ and there is } p \in V_p \subseteq U \text{ and } t \in \mathcal{F}(V_p) \text{ with } f(x) = t_p \text{ for all } x \in V_p\}.$$

See [77, II.1] for a proof that \mathcal{F}^+ is a sheaf with the same stalks as \mathcal{F}_p . Hence

$$U \longmapsto \text{im}(\phi_U)$$

has a natural sheaf associated to it, denoted $\text{im}(\phi)$.

Exactness. We define exact sequences of sheaves as follows.

Definition 6.0.6. A sequence of sheaves

$$\mathcal{F}^{i-1} \xrightarrow{d^{i-1}} \mathcal{F}^i \xrightarrow{d^i} \mathcal{F}^{i+1}$$

is **exact** at \mathcal{F}^i if there is an equality of sheaves

$$\ker(d^i) = \text{im}(d^{i-1}).$$

The local nature of sheaves is again highlighted by the following result, whose proof may be found in [77, II.1].

Proposition 6.0.7. *The sequence in Definition 6.0.6 is exact if and only if*

$$\mathcal{F}_p^{i-1} \xrightarrow{d_p^{i-1}} \mathcal{F}_p^i \xrightarrow{d_p^i} \mathcal{F}_p^{i+1}$$

is exact for all $p \in X$. □

It follows from Example 6.0.5 that if

$$(6.0.1) \quad 0 \longrightarrow \mathcal{F}^1 \xrightarrow{d^1} \mathcal{F}^2 \xrightarrow{d^2} \mathcal{F}^3 \longrightarrow 0$$

is a short exact sequence of sheaves, the corresponding sequence of global sections may fail to be exact. However, we always have the following partial exactness, which you will prove in Exercise 6.0.3.

Proposition 6.0.8. *Given a short exact sequence of sheaves (6.0.1), taking global sections gives the exact sequence*

$$0 \longrightarrow \Gamma(X, \mathcal{F}^1) \xrightarrow{d^1} \Gamma(X, \mathcal{F}^2) \xrightarrow{d^2} \Gamma(X, \mathcal{F}^3).$$

In Chapter 9 we will use *sheaf cohomology* to extend this exact sequence.

Example 6.0.9. For an affine variety $V = \text{Spec}(R)$, an R -module M gives a quasi-coherent sheaf \tilde{M} on V . This operation preserves exactness, i.e., an exact sequence of R -modules

$$0 \longrightarrow M_1 \longrightarrow M_2 \longrightarrow M_3 \longrightarrow 0$$

gives an exact sequence of sheaves

$$0 \longrightarrow \tilde{M}_1 \longrightarrow \tilde{M}_2 \longrightarrow \tilde{M}_3 \longrightarrow 0$$

(see [77, Prop. II.5.2]). ◇

Here is a toric generalization of this example.

Example 6.0.10. Let $S = \mathbb{C}[x_\rho \mid \rho \in \Sigma(1)]$ is the total coordinate ring of a toric variety X_Σ without torus factors. We saw in §5.3 that a graded S -module M gives the quasicoherent sheaf \tilde{M} on X .

Then an exact sequence $0 \rightarrow M_1 \rightarrow M_2 \rightarrow M_3 \rightarrow 0$ of graded S -modules gives an exact sequence

$$0 \longrightarrow \tilde{M}_1 \longrightarrow \tilde{M}_2 \longrightarrow \tilde{M}_3 \longrightarrow 0$$

on X_Σ . To see why, note that for $\sigma \in \Sigma$, the restriction of \tilde{M}_i to $U_\sigma \subseteq X_\Sigma$ is the sheaf associated to $((M_i)_{x^\sigma})_0$, the elements of degree 0 in the localization of M_i at $x^\sigma \in S$. Localization preserves exactness, as does taking elements of degree 0. The desired exactness then follows from Example 6.0.9. \diamond

Another example is the following exact sequence of sheaves from §3.0.

Example 6.0.11. A closed subvariety $i : Y \hookrightarrow X$ gives two sheaves:

- The sheaf \mathcal{I}_Y , defined by $\mathcal{I}_Y(U) = \{f \in \mathcal{O}_X(U) \mid f(p) = 0 \text{ for } p \in Y \cap U\}$.
- The direct image sheaf $i_*\mathcal{O}_Y$, defined by $i_*\mathcal{O}_Y(U) = \mathcal{O}_Y(Y \cap U)$.

These are coherent sheaves on X and are related by the exact sequence

$$0 \longrightarrow \mathcal{I}_Y \longrightarrow \mathcal{O}_X \longrightarrow i_*\mathcal{O}_Y \longrightarrow 0. \quad \diamond$$

Operations on Quasicoherent Sheaves of \mathcal{O}_X . Operations on modules over a ring have natural analogs for quasicoherent sheaves. In particular, given quasicoherent sheaves \mathcal{F}, \mathcal{G} , it is easy to show that $U \mapsto \mathcal{F}(U) \oplus \mathcal{G}(U)$ defines the quasicoherent sheaf $\mathcal{F} \oplus \mathcal{G}$. We can also define $\text{Hom}_{\mathcal{O}_X}(\mathcal{F}, \mathcal{G})$ via

$$U \longmapsto \text{Hom}_{\mathcal{O}_X(U)}(\mathcal{F}(U), \mathcal{G}(U)).$$

In Exercise 6.0.4 you will show that $\text{Hom}_{\mathcal{O}_X}(\mathcal{F}, \mathcal{G})$ is a quasicoherent sheaf.

On the other hand, $U \mapsto \mathcal{F}(U) \otimes_{\mathcal{O}_X(U)} \mathcal{G}(U)$ is only a presheaf, so the tensor product $\mathcal{F} \otimes_{\mathcal{O}_X} \mathcal{G}$ is defined to be the sheaf associated to this presheaf. This sheaf is again quasicoherent and satisfies

$$\Gamma(U, \mathcal{F} \otimes_{\mathcal{O}_X} \mathcal{G}) = \mathcal{F}(U) \otimes_{\mathcal{O}_X(U)} \mathcal{G}(U)$$

whenever $U \subseteq X$ is an affine open set (see [77, Prop. II.5.2]).

Global Generation. For a module M over a ring, there is always a surjection from a free module onto M . This is true for a sheaf \mathcal{F} of \mathcal{O}_X -modules when $\Gamma(X, \mathcal{F})$ is, in a certain sense, large enough.

Definition 6.0.12. A sheaf \mathcal{F} of \mathcal{O}_X -modules is **generated by global sections** if there exists a set $\{s_i\} \subseteq \Gamma(X, \mathcal{F})$ such that at any point $p \in X$, the images of the s_i generate the stalk \mathcal{F}_p .

Any global section $s \in \Gamma(X, \mathcal{F})$ gives a sheaf homomorphism $\mathcal{O}_X \rightarrow \mathcal{F}$. It follows that if \mathcal{F} is generated by $\{s_i\}_{i \in I}$, there is a surjection of sheaves

$$\bigoplus_{i \in I} \mathcal{O}_X \longrightarrow \mathcal{F}.$$

In the next section we will see that when X is toric, there is a particularly nice way of determining when the sheaves $\mathcal{O}_X(D)$ are generated by global sections.

Locally Free Sheaves and Vector Bundles. We begin with locally free sheaves.

Definition 6.0.13. A sheaf \mathcal{F} of \mathcal{O}_X -modules is **locally free of rank r** if there exists an open cover $\{U_\alpha\}$ of X such that for all α , $\mathcal{F}|_{U_\alpha} \simeq \mathcal{O}_{U_\alpha}^r$.

Locally free sheaves are closely related to vector bundles.

Definition 6.0.14. A variety V is a **vector bundle of rank r** over a variety X if there is a morphism

$$\pi : V \longrightarrow X$$

and an open cover $\{U_i\}$ of X such that:

(a) For every i , there is an isomorphism

$$\phi_i : \pi^{-1}(U_i) \xrightarrow{\sim} U_i \times \mathbb{C}^r$$

such that ϕ_i followed by projection onto U_i is $\pi|_{\pi^{-1}(U_i)}$.

(b) For every pair i, j , there is $g_{ij} \in \mathrm{GL}_r(\Gamma(U_i \cap U_j, \mathcal{O}_X))$ such that the diagram

$$\begin{array}{ccc} & & U_i \cap U_j \times \mathbb{C}^r \\ & \nearrow \phi_i|_{\pi^{-1}(U_i \cap U_j)} & \uparrow 1 \times g_{ij} \\ \pi^{-1}(U_i \cap U_j) & & \\ & \searrow \phi_j|_{\pi^{-1}(U_i \cap U_j)} & \downarrow \\ & & U_i \cap U_j \times \mathbb{C}^r \end{array}$$

commutes.

Data $\{(U_i, \phi_i)\}$ satisfying properties (a) and (b) is called a *trivialization*. The map $\phi_i : \pi^{-1}(U_i) \simeq U_i \times \mathbb{C}^r$ gives a *chart*, where $\pi^{-1}(p) \simeq \mathbb{C}^r$ for $p \in U_i$. We call $\pi^{-1}(p)$ the *fiber* over p . See Figure 1 on the next page.

For $p \in U_i \cap U_j$, the isomorphisms

$$\mathbb{C}^r \simeq \{p\} \times \mathbb{C}^r \xleftarrow{\sim} \pi^{-1}(p) \xrightarrow{\sim} \{p\} \times \mathbb{C}^r \simeq \mathbb{C}^r$$

given by ϕ_i and ϕ_j are related by the linear map $g_{ij}(p)$. Hence the fiber $\pi^{-1}(p)$ has a well-defined vector space structure. This shows that a vector bundle really is a “bundle” of vector spaces.

On a vector bundle, the g_{ij} are called *transition functions* and can be regarded as a *family* of transition matrices that vary as $p \in U_i$ varies. Just as there is no preferred basis for a vector space, there is no canonical choice of basis for a particular fiber. Note also that the transition functions satisfy the compatibility conditions

$$(6.0.2) \quad \begin{aligned} g_{ik} &= g_{ij} \circ g_{jk} \quad \text{on } U_i \cap U_j \cap U_k \\ g_{ij} &= g_{ji}^{-1} \quad \text{on } U_i \cap U_j. \end{aligned}$$

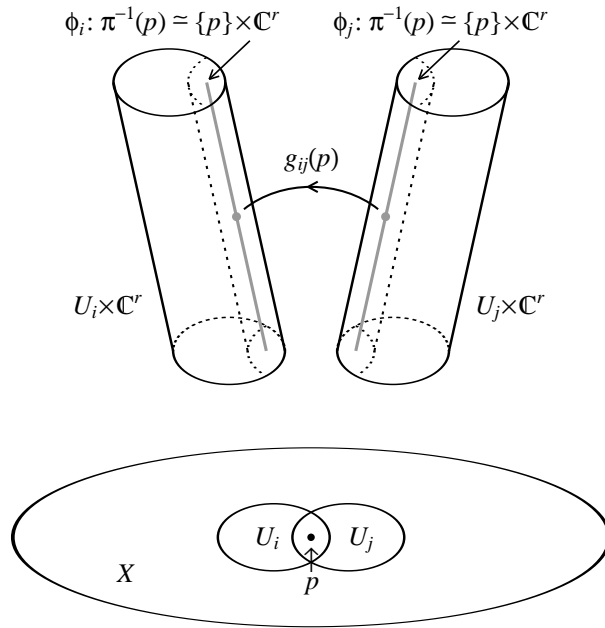

Figure 1. Visualizing a vector bundle

Definition 6.0.15. A *section* of a vector bundle V over $U \subseteq X$ open is a morphism

$$s : U \longrightarrow V$$

such that $\pi \circ s(p) = p$ for all $p \in U$. A section $s : X \rightarrow V$ is a *global section*.

A section s picks out a point $s(p)$ in each fiber $\pi^{-1}(p)$, as shown in Figure 2.

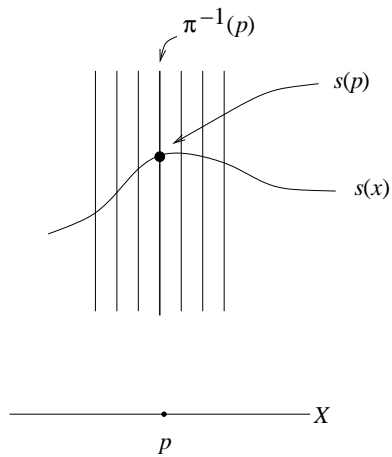

Figure 2. For a section s , $s(p) \in \pi^{-1}(p)$

We can describe a vector bundle and its global sections purely in terms of the transition functions g_{ij} as follows.

Proposition 6.0.16. *Let X be a variety with an affine open cover $\{U_i\}$, and assume that for every i, j , we have $g_{ij} \in \mathrm{GL}_r(\Gamma(U_i \cap U_j, \mathcal{O}_X))$ satisfying the compatibility conditions (6.0.2). Then:*

- (a) *There is a vector bundle $\pi : V \rightarrow X$ of rank r , unique up to isomorphism, whose transition functions are the g_{ij} .*
- (b) *A global section $s : X \rightarrow V$ is uniquely determined by a collection of r -tuples $s_i \in \mathcal{O}_X^r$ such that for all i, j ,*

$$s_i|_{U_i \cap U_j} = g_{ij} s_j|_{U_i \cap U_j}.$$

Proof. One easily checks that the g_{ij}^{-1} satisfy the gluing conditions from §3.0. It follows that the affine varieties $U_i \times \mathbb{C}^r$ glue together to give a variety V . Furthermore, the projection maps $U_i \times \mathbb{C}^r \rightarrow U_i$ glue together to give a morphism $\pi : V \rightarrow X$. It follows easily that the open set of V corresponding to $U_i \times \mathbb{C}^r$ is $\pi^{-1}(U_i)$, which gives an isomorphism $\phi_i : \pi^{-1}(U_i) \simeq U_i \times \mathbb{C}^r$. Hence V is a vector bundle with transition functions g_{ij} .

Given a section $s : X \rightarrow V$, $\phi_i \circ s|_{U_i}$ is a section of $U_i \times \mathbb{C}^r \rightarrow U_i$. Thus

$$\phi_i \circ s|_{U_i}(p) = (p, s_i(p)) \in U_i \times \mathbb{C}^r,$$

where $s_i \in \mathcal{O}_X(U_i)^r$. By Definition 6.0.14, the s_i satisfy the desired compatibility condition, and since every global section arises this way, we are done. \square

Let $\mathcal{F}(U)$ denote the set of all sections of V over U . One easily sees that \mathcal{F} is a sheaf on X and in fact is a sheaf of \mathcal{O}_X -modules since the fibers are vector spaces. In fact, \mathcal{F} is an especially nice sheaf.

Proposition 6.0.17. *The sheaf of sections of a vector bundle is locally free.*

Proof. For a trivial vector bundle $U \times \mathbb{C}^r \rightarrow U$, the proof of Proposition 6.0.16 shows that a section is determined by a morphism $U \rightarrow \mathbb{C}^r$, i.e., an element of $\mathcal{O}_U(U)^r$. Thus the sheaf associated to a trivial vector bundle over U is \mathcal{O}_U^r .

For a general vector bundle $\pi : V \rightarrow X$ with trivialization $\{(U_i, \phi_i)\}$, each U_i gives an isomorphism of vector bundles

$$\begin{array}{ccc} \pi^{-1}(U_i) & \xrightarrow{\phi_i} & U_i \times \mathbb{C}^r \\ & \searrow & \swarrow \\ & \pi|_{\pi^{-1}(U_i)} & U_i. \end{array}$$

Since isomorphic vector bundles have isomorphic sheaves of sections, it follows that if \mathcal{F} is the sheaf of sections of $\pi : V \rightarrow X$, then $\mathcal{F}|_{U_i} \simeq \mathcal{O}_{U_i}^r$. \square

Line Bundles and Cartier Divisors. Since a vector space of dimension one is a line, a vector bundle of rank 1 is called a *line bundle*. Despite the new terminology, line bundles are actually familiar objects when X is normal.

Theorem 6.0.18. *The sheaf $\mathcal{L} = \mathcal{O}_X(D)$ of a Cartier divisor D on a normal variety X is the sheaf of sections of a line bundle $V_{\mathcal{L}} \rightarrow X$.*

Proof. Recall from Chapter 4 that a Cartier divisor is locally principal, so that X has an affine open cover $\{U_i\}_{i \in I}$ with $D|_{U_i} = \text{div}(f_i)|_{U_i}$, $f_i \in \mathbb{C}(X)^*$. Thus $\{(U_i, f_i)\}_{i \in I}$ is local data for D . Note also that

$$\text{div}(f_i)|_{U_i \cap U_j} = \text{div}(f_j)|_{U_i \cap U_j},$$

which implies $f_i/f_j \in \mathcal{O}_X(U_i \cap U_j)^*$ by Proposition 4.0.16.

We use this data to construct a line bundle as follows. Since

$$\text{GL}_1(\mathcal{O}_X(U_i \cap U_j)) = \mathcal{O}_X(U_i \cap U_j)^*,$$

the quotients $g_{ij} = f_i/f_j$ may be regarded as transition functions. These satisfy the hypotheses of Proposition 6.0.16 and hence give a line bundle $\pi : V_{\mathcal{L}} \rightarrow X$.

A global section $f \in \Gamma(X, \mathcal{O}_X(D))$ satisfies $\text{div}(f) + D \geq 0$, so that on U_i ,

$$\text{div}(ff_i)|_{U_i} = \text{div}(f)|_{U_i} + \text{div}(f_i)|_{U_i} = (\text{div}(f) + D)|_{U_i} \geq 0.$$

This shows that $s_i = f_i f \in \mathcal{O}_X(D)(U_i)$. Then

$$g_{ij}s_j = f_i/f_j \cdot f_j f = f_i f = s_i,$$

which by part (b) of Proposition 6.0.16 gives a global section of $\pi : V_{\mathcal{L}} \rightarrow X$. Conversely, the proposition shows that a global section of $V_{\mathcal{L}} \rightarrow X$ gives functions $s_i \in \mathcal{O}_X(D)(U_i)$ such that $g_{ij}s_j = s_i$. It follows that $f = s_i/f_i \in \mathbb{C}(X)$ is independent of i . One easily checks that $f \in \Gamma(X, \mathcal{O}_X(D))$. The same argument works when we restrict to any open subset of X . It follows that $\mathcal{L} = \mathcal{O}_X(D)$ is the sheaf of sections of $\pi : V_{\mathcal{L}} \rightarrow X$. \square

We will see shortly that this process is reversible, i.e., there is a one-to-one correspondence between line bundles and sheaves coming from Cartier divisors. First, we give an important example.

Example 6.0.19. When we regard \mathbb{P}^n as the set of lines through the origin in \mathbb{C}^{n+1} , each point $p \in \mathbb{P}^n$ corresponds to a line $\ell_p \subseteq \mathbb{C}^{n+1}$. We assemble these lines into a line bundle as follows. Let x_0, \dots, x_n be homogeneous coordinates on \mathbb{P}^n and y_0, \dots, y_n be coordinates on \mathbb{C}^{n+1} . Define

$$V \subseteq \mathbb{P}^n \times \mathbb{C}^{n+1}$$

as the locus where the matrix

$$\begin{pmatrix} x_0 & \cdots & x_n \\ y_0 & \cdots & y_n \end{pmatrix}$$

has rank one. Thus V is defined by the vanishing of $x_i y_j - x_j y_i$. Then define the map $\pi : V \rightarrow \mathbb{P}^n$ to be projection on the first factor of $\mathbb{P}^n \times \mathbb{C}^{n+1}$. To see that V is a line bundle, consider the open subset $\mathbb{C}^n \simeq U_i \subseteq \mathbb{P}^n$ where x_i is invertible. On $\pi^{-1}(U_i)$ the equations defining V become

$$\frac{x_j}{x_i} y_i = y_j, \quad \text{for all } j \neq i.$$

Thus $(x_0, \dots, x_n, y_0, \dots, y_n) \mapsto (x_0, \dots, x_n, y_i)$ defines an isomorphism

$$\phi_i : \pi^{-1}(U_i) \xrightarrow{\sim} U_i \times \mathbb{C}.$$

In other words, y_i is a local coordinate for the line \mathbb{C} over U_i . Switching to the coordinate system over U_j , we have the local coordinate y_j , which over $U_i \cap U_j$ is related to y_i via

$$\frac{x_i}{x_j} y_j = y_i.$$

Hence the transition function from $U_i \cap U_j \times \mathbb{C}$ to $U_i \cap U_j \times \mathbb{C}$ is given by

$$g_{ij} = \frac{x_i}{x_j} \in \mathcal{O}_{\mathbb{P}^n}(U_i \cap U_j)^*.$$

This bundle is called the *tautological bundle* on \mathbb{P}^n . In Example 6.0.21 below, we will describe the sheaf of sections of this bundle. \diamond

Projective spaces are the simplest type of Grassmannian, and just as in this example, the construction of the Grassmannian shows that it comes equipped with a tautological vector bundle. In Exercise 6.0.5 you will determine the transition functions for the Grassmannian $\mathbb{G}(1, 3)$.

Invertible Sheaves and the Picard Group. Propositions 6.0.17 and 6.0.18 imply that the sheaf $\mathcal{O}_X(D)$ of a Cartier divisor is locally free of rank 1. In general, a locally free sheaf of rank 1 is called an *invertible sheaf*.

The relation between Cartier divisors, line bundles and invertible sheaves is described in the following theorem.

Theorem 6.0.20. *Let \mathcal{L} be an invertible sheaf on a normal variety X . Then:*

- (a) *There is a Cartier divisor D on X such that $\mathcal{L} \simeq \mathcal{O}_X(D)$.*
- (b) *There is a line bundle $V_{\mathcal{L}} \rightarrow X$ whose sheaf of sections is isomorphic to \mathcal{L} .*

Proof. The part (b) of the theorem follows from part (a) and Proposition 6.0.18. It remains to prove part (a).

Since X is irreducible, any nonempty open $U \subseteq X$ gives a domain $\mathcal{O}_X(U)$ with field of fractions $\mathbb{C}(U)$. By Exercise 3.0.4, $\mathbb{C}(U) = \mathbb{C}(X)$, so that $U \mapsto \mathbb{C}(U)$ defines a constant sheaf on X , denoted \mathcal{K}_X . This sheaf is relevant since $\mathcal{O}_X(D)$ is defined as a subsheaf of \mathcal{K}_X .

First assume that \mathcal{L} is a subsheaf of \mathcal{K}_X . Pick an open cover $\{U_i\}$ of X such that $\mathcal{L}|_{U_i} \simeq \mathcal{O}_X|_{U_i}$ for every i . Over U_i , this gives homomorphisms

$$\mathcal{O}_X(U_i) \simeq \mathcal{L}(U_i) \hookrightarrow \mathbb{C}(X).$$

Let $f_i^{-1} \in \mathbb{C}(X)$ be the image of $1 \in \mathcal{O}_X(U_i)$. One can show without difficulty that $f_i/f_j \in \mathcal{O}_X(U_i \cap U_j)^*$. Then $\{(U_i, f_i)\}$ is local data for a Cartier divisor D on X satisfying $\mathcal{L} = \mathcal{O}_X(D)$.

For the general case, observe that on an irreducible variety, every locally constant sheaf is globally constant (Exercise 6.0.6). Now let \mathcal{L} be any invertible sheaf on X . On a small enough open set U , $\mathcal{L}(U) \simeq \mathcal{O}_X(U)$, so that

$$\mathcal{L}(U) \otimes_{\mathcal{O}_X(U)} \mathcal{K}_X(U) \simeq \mathcal{O}_X(U) \otimes_{\mathcal{O}_X(U)} \mathcal{K}_X(U) \simeq \mathcal{K}_X(U) = \mathbb{C}(X).$$

Thus $\mathcal{L} \otimes_{\mathcal{O}_X} \mathcal{K}_X$ is locally constant and hence constant. This easily implies that $\mathcal{L} \otimes_{\mathcal{O}_X} \mathcal{K}_X \simeq \mathcal{K}_X$, and composing this with the inclusion

$$\mathcal{L} \longrightarrow \mathcal{L} \otimes_{\mathcal{O}_X} \mathcal{K}_X$$

expresses \mathcal{L} as a subsheaf of \mathcal{K}_X . □

We note without proof that the line bundle corresponding to an invertible sheaf is unique up to isomorphism. Because of this result, algebraic geometers tend to use the terms *line bundle* and *invertible sheaf* interchangeably, even though strictly speaking the latter is the sheaf of sections of the former.

We next discuss some properties of invertible sheaves coming from Cartier divisors. A first result is that if D and E are Cartier divisors on X , then

$$(6.0.3) \quad \mathcal{O}_X(D) \otimes_{\mathcal{O}_X} \mathcal{O}_X(E) \simeq \mathcal{O}_X(D + E).$$

This follows because $f \otimes g \mapsto fg$ induces a sheaf homomorphism

$$\mathcal{O}_X(D) \otimes_{\mathcal{O}_X} \mathcal{O}_X(E) \longrightarrow \mathcal{O}_X(D + E)$$

which is clearly an isomorphism on any open set where $\mathcal{O}_X(D)$ is trivial.

By standard properties of tensor product, the isomorphism (6.0.3) induces an isomorphism

$$\mathcal{O}_X(E) \simeq \mathcal{H}om_{\mathcal{O}_X}(\mathcal{O}_X(D), \mathcal{O}_X(D + E)).$$

In particular, when $E = -D$, we obtain

$$\mathcal{O}_X(D) \otimes_{\mathcal{O}_X} \mathcal{O}_X(-D) \simeq \mathcal{O}_X \quad \text{and} \quad \mathcal{O}_X(-D) \simeq \mathcal{O}_X(D)^\vee,$$

where $\mathcal{O}_X(D)^\vee = \mathcal{H}om_{\mathcal{O}_X}(\mathcal{O}_X(D), \mathcal{O}_X)$ is the *dual* of $\mathcal{O}_X(D)$.

More generally, the tensor product of invertible sheaves is again invertible, and if \mathcal{L} is invertible, then $\mathcal{L}^\vee = \mathcal{H}om_{\mathcal{O}_X}(\mathcal{L}, \mathcal{O}_X)$ is invertible and

$$\mathcal{L} \otimes_{\mathcal{O}_X} \mathcal{L}^\vee \simeq \mathcal{O}_X.$$

This explains why locally free sheaves of rank 1 are called invertible.

Example 6.0.21. There is a nice relation between the tautological bundle on \mathbb{P}^n and the invertible sheaf $\mathcal{O}_{\mathbb{P}^n}(1)$ introduced in Example 4.3.1. Recall that the T_N -invariant divisors D_0, \dots, D_n on \mathbb{P}^n are all linearly equivalent, and so define isomorphic sheaves, usually denoted $\mathcal{O}_{\mathbb{P}^n}(1)$. The local data for the Cartier divisor D_0 is easily seen to be $\{(U_i, \frac{x_0}{x_i})\}$, where $U_i \subseteq \mathbb{P}^n$ is the open set where $x_i \neq 0$. Thus the transition functions for $\mathcal{O}_X(D_0)$ are given by

$$g_{ij} = \frac{\frac{x_0}{x_i}}{\frac{x_0}{x_j}} = \frac{x_j}{x_i}.$$

These are the inverses of the transition functions for the tautological bundle from Example 6.0.19. It follows that the sheaf of sections of the tautological bundle is $\mathcal{O}_{\mathbb{P}^n}(1)^\vee = \mathcal{O}_{\mathbb{P}^n}(-1)$. \diamond

We can also explain when Cartier divisors give isomorphic invertible sheaves.

Proposition 6.0.22. *Two Cartier divisors D, E give isomorphic invertible sheaves $\mathcal{O}_X(D) \simeq \mathcal{O}_X(E)$ if and only if $D \sim E$.*

Proof. By Proposition 4.0.29, linearly equivalent Cartier divisors give isomorphic sheaves. For the converse, we first prove that $\mathcal{O}_X(D) = \mathcal{O}_X$ implies $D = 0$.

Assume $\mathcal{O}_X(D) = \mathcal{O}_X$. Then $1 \in \Gamma(X, \mathcal{O}_X) = \Gamma(X, \mathcal{O}_X(D))$, so $D \geq 0$. If $D \neq 0$, then we can pick an irreducible divisor D_0 that appears in D with positive coefficient. The local ring \mathcal{O}_{X, D_0} is a DVR, so we can find $h \in \mathcal{O}_{X, D_0}$ with $\nu_{D_0}(h) = 1$. Set $U = X \setminus W$, where W is the union of all irreducible divisors $D' \neq D_0$ with $\nu_{D'}(h) \neq 0$. There are only finitely many such divisors, so that U is a nonempty open subset of X with $U \cap D_0 \neq \emptyset$. Then $h \in \Gamma(U, \mathcal{O}_X)$, and $h^{-1} \notin \Gamma(U, \mathcal{O}_X)$ since h vanishes on $U \cap D_0$. However,

$$(D + \operatorname{div}(h^{-1}))|_U = (D - \operatorname{div}(h))|_U = (D - D_0)|_U \geq 0,$$

so that $h^{-1} \in \Gamma(U, \mathcal{O}_X(D)) = \Gamma(U, \mathcal{O}_X)$. This contradiction proves $D = 0$.

Now suppose that Cartier divisors D, E satisfy $\mathcal{O}_X(D) \simeq \mathcal{O}_X(E)$. Tensoring each side with $\mathcal{O}_X(-E)$ and applying (6.0.3), we see that $\mathcal{O}_X(D - E) \simeq \mathcal{O}_X$. If $1 \in \Gamma(X, \mathcal{O}_X)$ maps to $g \in \Gamma(X, \mathcal{O}_X(D - E))$ via this isomorphism, then

$$g\mathcal{O}_X = \mathcal{O}_X(D - E)$$

as subsheaves of \mathcal{K}_X . Thus

$$\mathcal{O}_X = g^{-1}\mathcal{O}_X(D - E) = \mathcal{O}(D - E + \operatorname{div}(g)),$$

where the last equality follows from the proof of Proposition 4.0.29. By the previous paragraph, we have $D - E + \operatorname{div}(g) = 0$, which implies that $D \sim E$. \square

In Chapter 4, the Picard group was defined as the quotient

$$\operatorname{Pic}(X) = \operatorname{CDiv}(X)/\operatorname{Div}_0(X).$$

We can interpret this in terms of invertible sheaves as follows. Given \mathcal{L} invertible, Theorem 6.0.20 tells us that $\mathcal{L} \simeq \mathcal{O}_X(D)$ for some Cartier divisor D , which is unique up to linear equivalence by Proposition 6.0.22. Hence we have a bijection

$$\text{Pic}(X) \simeq \{\text{isomorphism classes of invertible sheaves on } X\}.$$

The right-hand side has a group structure coming from tensor product of invertible sheaves. By (6.0.3), the above bijection is a group isomorphism.

In more sophisticated treatments of algebraic geometry, the Picard group of an arbitrary variety is defined using invertible sheaves. Also, Cartier divisors can be defined on an irreducible variety in terms of local data, without assuming normality (see [77, II.6]), though one loses the connection with Weil divisors. Since most of our applications involve toric varieties coming from fans, we will continue to assume normality when discussing Cartier divisors.

Stalks, Fibers, and Sections. From here on, we will think of a line bundle \mathcal{L} on X as the sheaf of sections of a rank 1 vector bundle $\pi : V_{\mathcal{L}} \rightarrow X$. Given a section $s \in \mathcal{L}(U)$ and $p \in U$, we get the following:

- Since $V_{\mathcal{L}}$ is a vector bundle of rank 1, we have the fiber $\pi^{-1}(p) \simeq \mathbb{C}$. Then $s : U \rightarrow V_{\mathcal{L}}$ gives $s(p) \in \pi^{-1}(p)$.
- Since \mathcal{L} is a locally free sheaf of rank 1, we have the stalk $\mathcal{L}_p \simeq \mathcal{O}_{X,p}$. Then $s \in \mathcal{L}(U)$ gives $s_p \in \mathcal{L}_p$.

In Exercise 6.0.7 you will show that these are related via the equivalences

$$(6.0.4) \quad \begin{aligned} s(p) \neq 0 \text{ in } \pi^{-1}(p) &\iff s_p \notin \mathfrak{m}_p \mathcal{L}_p \\ &\iff s_p \text{ generates } \mathcal{L}_p \text{ as an } \mathcal{O}_{X,p}\text{-module} \end{aligned}$$

A section s vanishes at $p \in X$ if $s(p) = 0$ in $\pi^{-1}(p)$, i.e., if $s_p \in \mathfrak{m}_p \mathcal{L}_p$.

Basepoints. It can happen that a collection of sections of a line bundle vanish at a point p . This leads to the following definition.

Definition 6.0.23. A subspace $W \subseteq \Gamma(X, \mathcal{L})$ *has no basepoints* or *is basepoint free* if for every $p \in X$, there is $s \in W$ with $s(p) \neq 0$.

As noted earlier, a global section $s \in \Gamma(X, \mathcal{L})$ gives a sheaf homomorphism $\mathcal{O}_X \rightarrow \mathcal{L}$. Thus a subspace $W \subseteq \Gamma(X, \mathcal{L})$ gives

$$W \otimes_{\mathbb{C}} \mathcal{O}_X \longrightarrow \mathcal{L}$$

defined by $s \otimes h \mapsto hs$. Then (6.0.4) and Proposition 6.0.7 imply the following.

Proposition 6.0.24. A subspace $W \subseteq \Gamma(X, \mathcal{L})$ has no basepoints if and only if $W \otimes_{\mathbb{C}} \mathcal{O}_X \rightarrow \mathcal{L}$ is surjective. \square

For a line bundle $\mathcal{L} = \mathcal{O}_X(D)$ of a Cartier divisor D on a normal variety, the vanishing locus of a global section has an especially nice interpretation. The local data $\{(U_i, f_i)\}$ of D gives the rank 1 vector bundle $\pi : V_{\mathcal{L}} \rightarrow X$ with transition functions $g_{ij} = f_i/f_j$. Hence we can think of a nonzero global section of $\mathcal{O}_X(D)$ in two ways:

- A rational function $f \in \mathbb{C}(X)^*$ satisfying $D + \text{div}(f) \geq 0$.
- A morphism $s : X \rightarrow V_{\mathcal{L}}$ whose composition with π is the identity on X .

The relation between s and f is given in the proof of Theorem 6.0.18: over U_i , the section s looks like $(p, s_i(p))$ for $s_i = f_i f \in \mathcal{O}_X(U_i)$. It follows that $s = 0$ exactly when $s_i = 0$. Since $D|_{U_i} = \text{div}(f_i)|_{U_i}$, the divisor of s_i on U_i is given by

$$\text{div}(f_i f)|_{U_i} = (D + \text{div}(f))|_{U_i}.$$

These patch together in the obvious way, so that the *divisor of zeros* of s is

$$\text{div}_0(s) = D + \text{div}(f).$$

Thus the divisor of zeros of a global section is an effective divisor that is linearly equivalent to D . It is also easy to see that *any* effective divisor linearly equivalent to D is the divisor of zeros of a global section of $\mathcal{O}_X(D)$ (Exercise 6.0.8).

In terms of Cartier divisors, Proposition 6.0.24 has the following corollary.

Corollary 6.0.25. *The following are equivalent for a Cartier divisor D :*

- $\mathcal{O}_X(D)$ is generated by global sections in the sense of Definition 6.0.12.
- D is **basepoint free**, meaning that $\Gamma(X, \mathcal{O}_X(D))$ is basepoint free.
- For every $p \in X$ there is $s \in \Gamma(X, \mathcal{O}_X(D))$ with $p \notin \text{Supp}(\text{div}_0(s))$. □

The Pullback of a Line Bundle. Let \mathcal{L} be a line bundle on X and $V_{\mathcal{L}} \rightarrow X$ the associated rank 1 vector bundle. A morphism $f : Z \rightarrow X$ gives the fibered product $f^*V_{\mathcal{L}} = V_{\mathcal{L}} \times_X Z$ from §3.0 that fits into the commutative diagram

$$\begin{array}{ccc} f^*V_{\mathcal{L}} & \longrightarrow & V_{\mathcal{L}} \\ \downarrow & & \downarrow \pi \\ Z & \xrightarrow{f} & X. \end{array}$$

It is easy to see that $f^*V_{\mathcal{L}}$ is a rank 1 vector bundle over Z .

Definition 6.0.26. The **pullback** $f^*\mathcal{L}$ of the sheaf \mathcal{L} is the sheaf of sections of the rank 1 vector bundle $f^*V_{\mathcal{L}}$ defined above.

Thus the pullback of a line bundle is again a line bundle. Furthermore, there is a natural map on global sections

$$f^* : \Gamma(X, \mathcal{L}) \longrightarrow \Gamma(Z, f^*\mathcal{L})$$

defined as follows. A global section $s : X \rightarrow V_{\mathcal{L}}$ gives the commutative diagram:

$$\begin{array}{ccc}
 Z & \xrightarrow{f} & X \\
 \downarrow 1_Z & \searrow f^*(s) & \downarrow s \\
 & f^*V_{\mathcal{L}} & V_{\mathcal{L}} \\
 & \downarrow & \downarrow \pi \\
 Z & \xrightarrow{f} & X
 \end{array}$$

The universal property of fibered products guarantees the existence and uniqueness of the dotted arrow $f^*(s) : Z \rightarrow f^*V_{\mathcal{L}}$ that makes the diagram commute. It follows that $f^*(s) \in \Gamma(Z, f^*\mathcal{L})$.

Example 6.0.27. Let $X \subseteq \mathbb{P}^n$ be a projective variety. If we write the inclusion as $i : X \hookrightarrow \mathbb{P}^n$, then the line bundle $\mathcal{O}_{\mathbb{P}^n}(1)$ gives the line bundle $i^*\mathcal{O}_{\mathbb{P}^n}(1)$ on X . When the projective embedding of X is fixed, this line bundle is often denoted $\mathcal{O}_X(1)$.

Thus a projective variety always comes equipped with a line bundle. However, it is not unique, since the same variety may have many projective embeddings. You will work out an example of this in Exercise 6.0.9. \diamond

In general, given a sheaf \mathcal{F} of \mathcal{O}_X -modules on X and a morphism $f : Z \rightarrow X$, one gets a sheaf $f^*\mathcal{F}$ of \mathcal{O}_Z -modules on Z . The definition is more complicated, so we refer the reader to [77, II.5] for the details.

Line Bundles and Maps to Projective Space. We now reverse Example 6.0.27 by using a line bundle \mathcal{L} on X to create a map to projective space.

Fix a finite-dimensional subspace $W \subseteq \Gamma(X, \mathcal{L})$ with no basepoints and let $W^\vee = \text{Hom}_{\mathbb{C}}(W, \mathbb{C})$ be its dual. The projective space of W^\vee is

$$\mathbb{P}(W^\vee) = (W^\vee \setminus \{0\})/\mathbb{C}^*.$$

We define a map $\phi_{\mathcal{L},W} : X \rightarrow \mathbb{P}(W^\vee)$ as follows. Fix $p \in X$ and pick a nonzero element $v_p \in \pi^{-1}(p) \simeq \mathbb{C}$, where $\pi : V_{\mathcal{L}} \rightarrow X$ is the rank 1 vector bundle associated to \mathcal{L} . For each $s \in W$, there is $\lambda_s \in \mathbb{C}$ such that $s(p) = \lambda_s v_p$. Then the map defined by $\ell_p(s) = \lambda_s$ is linear and nonzero since W has no base points. Thus $\ell_p \in W^\vee$, and since v_p is unique up to an element of \mathbb{C}^* , the same is true for ℓ_p . Then

$$\phi_{\mathcal{L},W}(p) = \ell_p$$

defines the desired map $\phi_{\mathcal{L},W} : X \rightarrow \mathbb{P}(W^\vee)$.

Lemma 6.0.28. *The map $\phi_{\mathcal{L},W} : X \rightarrow \mathbb{P}(W^\vee)$ is a morphism.*

Proof. Let s_0, \dots, s_m be a basis of W and let $U_i = \{p \in X \mid s_i(p) \neq 0\}$. These open sets cover X since W has no basepoints. Furthermore, the natural map

$$U_i \times \mathbb{C} \longrightarrow \pi^{-1}(U_i), \quad (p, \lambda) \longmapsto \lambda s_i(p)$$

is easily seen to be an isomorphism. Since all sections of $U_i \times \mathbb{C} \rightarrow \mathbb{C}$ are of the form $p \mapsto (p, h(p))$ for $h \in \mathcal{O}_X(U_i)$, it follows that for all $0 \leq j \leq m$, we can write $s_j|_{U_i} = h_{ij}s_i|_{U_i}$, $h_{ij} \in \mathcal{O}_X(U_i)$.

The definition of $\phi_{\mathcal{L}, W}$ uses a nonzero vector $v_p \in \pi^{-1}(p)$. Over U_i , we can use $s_i(p) \in \pi^{-1}(p)$. Then $s_j(p) = h_{ij}(p)s_i(p)$ implies $\ell_p(s_j(p)) = h_{ij}(p)$. Since $\ell \mapsto (\ell(s_0), \dots, \ell(s_m))$ gives an isomorphism $\mathbb{P}(W^\vee) \simeq \mathbb{P}^m$, $\phi_{\mathcal{L}, W}|_{U_i}$ can be written

$$(6.0.5) \quad U_i \longrightarrow \mathbb{P}^m, \quad p \longmapsto (h_{i0}(p), \dots, h_{im}(p)),$$

which is a morphism since $h_{ii} = 1$. \square

When W has no basepoints and s_0, \dots, s_m span W , $\phi_{\mathcal{L}, W}$ is often written

$$(6.0.6) \quad X \longrightarrow \mathbb{P}^m, \quad p \longmapsto (s_0(p), \dots, s_m(p)) \in \mathbb{P}^m$$

with the understanding that this means (6.0.5) on $U_i = \{p \in X \mid s_i(p) \neq 0\}$.

Furthermore, when $\mathcal{L} = \mathcal{O}_X(D)$, we can think of the global sections s_i as rational functions g_i such that $D + \operatorname{div}(g_i) \geq 0$. Then $\phi_{\mathcal{L}, W}$ can be written

$$(6.0.7) \quad X \longrightarrow \mathbb{P}^m, \quad p \longmapsto (g_0(p), \dots, g_m(p)) \in \mathbb{P}^m.$$

Since $g_i(p)$ may be undefined, this needs explanation. The local data $\{(U_j, f_j)\}$ of D implies that $f_j g_0, \dots, f_j g_m \in \mathcal{O}_X(U_j)$. Then (6.0.7) means that $\phi_{\mathcal{L}, W}|_{U_j}$ is

$$U_j \longrightarrow \mathbb{P}^m, \quad p \longmapsto (f_j g_0(p), \dots, f_j g_m(p)) \in \mathbb{P}^m.$$

This is a morphism on U_j since the global sections corresponding to g_0, \dots, g_m have no base points.

Exercises for §6.0.

6.0.1. For a sheaf homomorphism $\phi: \mathcal{F} \rightarrow \mathcal{G}$, show that

$$U \longmapsto \ker(\phi_U)$$

defines a sheaf. Also prove that the following are equivalent:

- (a) The kernel sheaf is identically zero.
- (b) ϕ_U is injective for every open subset U .
- (c) ϕ is injective as defined in Definition 6.0.4.

6.0.2. In Example 6.0.5, prove that $\mathcal{O}_{\mathbb{P}^1}(-D) \oplus \mathcal{O}_{\mathbb{P}^1}(-D) \rightarrow \mathcal{O}_{\mathbb{P}^1}$ is surjective.

6.0.3. Prove Proposition 6.0.8.

6.0.4. Let \mathcal{F}, \mathcal{G} be quasicohherent sheaves on X . Prove that $U \mapsto \operatorname{Hom}_{\mathcal{O}_X(U)}(\mathcal{F}(U), \mathcal{G}(U))$ defines a quasicohherent sheaf $\mathcal{H}om_{\mathcal{O}_X}(\mathcal{F}, \mathcal{G})$.

6.0.5. The Grassmannian $\mathbb{G}(1, 3)$ is defined as the space of lines in \mathbb{P}^3 , or equivalently, of 2-dimensional subspaces of $V = \mathbb{C}^4$. This exercise will construct the *tautological bundle* on $\mathbb{G}(1, 3)$, which assembles these 2-dimensional subspaces into a rank 2 vector bundle over $\mathbb{G}(1, 3)$. A point of $\mathbb{G}(1, 3)$ corresponds to a full rank matrix

$$p = \begin{pmatrix} \alpha \\ \beta \end{pmatrix} = \begin{pmatrix} \alpha_0 & \alpha_1 & \alpha_2 & \alpha_3 \\ \beta_0 & \beta_1 & \beta_2 & \beta_3 \end{pmatrix}$$

up to left multiplication by elements of $\mathrm{GL}_2(\mathbb{C})$. Then define

$$V \subseteq \mathbb{G}(1, 3) \times \mathbb{C}^4$$

to consist of all pairs $((\begin{smallmatrix} \alpha \\ \beta \end{smallmatrix}), v)$ such that $v \in \mathrm{Span}(\alpha, \beta)$.

(a) A pair $((\begin{smallmatrix} \alpha \\ \beta \end{smallmatrix}), v)$ gives the 3×4 matrix

$$A = \begin{pmatrix} v \\ \alpha \\ \beta \end{pmatrix} = \begin{pmatrix} v_0 & v_1 & v_2 & v_3 \\ \alpha_0 & \alpha_1 & \alpha_2 & \alpha_3 \\ \beta_0 & \beta_1 & \beta_2 & \beta_3 \end{pmatrix}.$$

Prove that $((\begin{smallmatrix} \alpha \\ \beta \end{smallmatrix}), v)$ is a point of V if and only if the maximal minors of A vanish. This shows that $V \subseteq \mathbb{G}(1, 3) \times \mathbb{C}^4$ is a closed subvariety.

(b) Projection onto the first factor gives a morphism $\pi : V \rightarrow \mathbb{G}(1, 3)$. Explain why the fiber over $p \in \mathbb{G}(1, 3)$ is the 2-dimensional subspace of \mathbb{C}^4 corresponding to p .

(c) Given $0 \leq i < j \leq 3$, define

$$U_{ij} = \{(\begin{smallmatrix} \alpha \\ \beta \end{smallmatrix}) \in \mathbb{G}(1, 3) \mid \alpha_i \beta_j - \alpha_j \beta_i \neq 0\}.$$

Prove that $U_{ij} \simeq \mathbb{C}^4$ and that the U_{ij} give an affine open cover of $\mathbb{G}(1, 3)$.

(d) Given $0 \leq i < j \leq 3$, pick $k < l$ such that $\{i, j, k, l\} = \{0, 1, 2, 3\}$. Prove that the map $(p, v) \mapsto (p, v_k, v_l)$ gives an isomorphism

$$\pi^{-1}(U_{ij}) \xrightarrow{\sim} U_{ij} \times \mathbb{C}^2.$$

(e) By part (d), V is a vector bundle over $\mathbb{G}(1, 3)$. Determine its transition functions.

6.0.6. Prove that a locally constant sheaf on an irreducible variety is constant.

6.0.7. Prove (6.0.4).

6.0.8. Prove that an effective divisor linearly equivalent to a Cartier divisor D is the divisor of zeros of a global section of $\mathcal{O}_X(D)$.

6.0.9. Let $\nu_d : \mathbb{P}^1 \rightarrow \mathbb{P}^d$ be the Veronese mapping defined in Example 2.3.14. Prove that $\nu_d^* \mathcal{O}_{\mathbb{P}^d}(1) = \mathcal{O}_{\mathbb{P}^1}(d)$.

6.0.10. Let $f : Z \rightarrow X$ be a morphism and let \mathcal{L} be a line bundle on X that is generated by global sections. Prove that the pullback line bundle $f^* \mathcal{L}$ is generated by global sections.

6.0.11. Let D be a Cartier divisor on a complete normal variety X .

(a) $f, g \in \Gamma(X, \mathcal{O}_X(D)) \setminus \{0\}$ give effective divisors $D + \mathrm{div}(f), D + \mathrm{div}(g)$ on X . Prove that these divisors are equal if and only if $f = \lambda g, \lambda \in \mathbb{C}^*$.

(b) The *complete linear system* of D is defined to be

$$|D| = \{E \in \mathrm{CDiv}(X) \mid E \sim D, E \geq 0\}.$$

Thus the complete linear system of D consists of all effective Cartier divisors on X linearly equivalent to D . Use part (a) to show that $|D|$ can be identified with the projective space of $\Gamma(X, \mathcal{O}_X(D))$, i.e., there is a natural bijection

$$|D| = \mathbb{P}(\Gamma(X, \mathcal{O}_X(D))) = (\Gamma(X, \mathcal{O}_X(D)) \setminus \{0\}) / \mathbb{C}^*.$$

(c) Assume that D has no basepoints and set $W = \Gamma(X, \mathcal{O}_X(D))$. Then $\mathbb{P}(W^\vee)$ can be identified with the set hyperplanes in $\mathbb{P}(W) = |D|$. Prove that the morphism $\phi_{\mathcal{O}_X(D), W} : X \rightarrow \mathbb{P}(W^\vee)$ is given by

$$\phi_{\mathcal{O}_X(D), W} = \{E \in |D| \mid p \in \mathrm{Supp}(E)\} \subseteq |D|.$$

§6.1. Ample Divisors on Complete Toric Varieties

Our aim in this section is to determine when a Cartier divisor on a complete toric variety gives a projective embedding. We will use the key concept of *ampleness*.

Definition 6.1.1. Let D be a Cartier divisor on a complete normal variety X . As we noted in §4.3, $W = \Gamma(X, \mathcal{O}_X(D))$ is finite-dimensional.

- (a) The divisor D and the line bundle $\mathcal{O}_X(D)$ are **very ample** when D has no basepoints and $\phi_D = \phi_{\mathcal{O}_X(D), W} : X \rightarrow \mathbb{P}(W^\vee)$ is a closed embedding.
- (b) D and $\mathcal{O}_X(D)$ are **ample** when kD is very ample for some integer $k > 0$.

Our discussion will tie together concepts from earlier sections, including:

- The very ample polytopes from Definition 2.2.16.
- The polyhedra P_D from Proposition 4.3.3.
- The support functions of Cartier divisors from Theorem 4.2.12.

We will see that support functions give a simple, elegant characterization of when D is ample, as well as when D is basepoint free.

Basepoint Free Divisors. Consider the toric variety X_Σ of a complete fan Σ in $N_{\mathbb{R}} \simeq \mathbb{R}^n$ and let $D = \sum_{\rho} a_{\rho} D_{\rho}$ be a torus-invariant Cartier divisor on X_Σ . By Propositions 4.3.3 and 4.3.8, we have the global sections

$$\Gamma(X_\Sigma, \mathcal{O}_{X_\Sigma}(D)) = \bigoplus_{m \in P_D \cap M} \mathbb{C} \cdot \chi^m,$$

where $P_D \subseteq M_{\mathbb{R}}$ is the polytope defined by

$$P_D = \{m \in M_{\mathbb{R}} \mid \langle m, u_{\rho} \rangle \geq -a_{\rho} \text{ for all } \rho \in \Sigma(1)\}.$$

We first study when $D = \sum_{\rho} a_{\rho} D_{\rho}$ is basepoint free. Recall from §4.2 that being Cartier means that for every $\sigma \in \Sigma$, there is $m_{\sigma} \in M$ with

$$(6.1.1) \quad \langle m_{\sigma}, u_{\rho} \rangle = -a_{\rho}, \quad \rho \in \sigma(1).$$

Furthermore, D is uniquely determined by the Cartier data $\{m_{\sigma}\}_{\sigma \in \Sigma(n)}$ since Σ is complete. Then we have the following preliminary result.

Proposition 6.1.2. *The following are equivalent:*

- (a) D has no basepoints, i.e., $\mathcal{O}_{X_\Sigma}(D)$ is generated by global sections.
- (b) $m_{\sigma} \in P_D$ for all $\sigma \in \Sigma(n)$.

Proof. First suppose that D is generated by global sections and take $\sigma \in \Sigma(n)$. The T_N -orbit corresponding to σ is a fixed point p of the T_N -action, and by the Orbit-Cone Correspondence,

$$\{p\} = \bigcap_{\rho \in \sigma(1)} D_{\rho}.$$

By Corollary 6.0.25, there is a global section s such that p is not in the support of the divisor of zeros $\text{div}_0(s)$ of s . Since $\Gamma(X_\Sigma, \mathcal{O}_{X_\Sigma}(D))$ is spanned by χ^m for $m \in P_D \cap M$, we can assume that s is given by χ^m for some $m \in P_D \cap M$. The discussion preceding Corollary 6.0.25 shows that the divisor of zeros of s is

$$\text{div}_0(s) = D + \text{div}(\chi^m) = \sum_{\rho} (a_{\rho} + \langle m, u_{\rho} \rangle) D_{\rho}.$$

The point p is not in the support of $\text{div}_0(s)$ yet lies in D_{ρ} for every $\rho \in \sigma(1)$. This forces $a_{\rho} + \langle m, u_{\rho} \rangle = 0$ for $\rho \in \sigma(1)$. Since σ is n -dimensional, we conclude that

For the converse, take $\sigma \in \Sigma(n)$. Since $m_{\sigma} \in P_D$, the character $\chi^{m_{\sigma}}$ gives a global section s whose divisor of zeros is $\text{div}_0(s) = D + \text{div}(\chi^{m_{\sigma}})$. Using (6.1.1), one sees that the support of $\text{div}_0(s)$ misses U_{σ} , so that s is nonvanishing on U_{σ} . Then we are done since the U_{σ} cover X_{Σ} . \square

Later in the section we will improve this result by showing that (b) is equivalent to the stronger condition that the m_{σ} , $\sigma \in \Sigma(n)$, are the vertices of P_D . This will imply in particular that P_D is a lattice polytope when D is basepoint free. We will also relate Proposition 6.1.2 to the convexity of the corresponding support function.

If D is generated by global sections, we can write the corresponding map to projective space as follows. Suppose that

$$P_D \cap M = \{m_1, \dots, m_s\}.$$

The characters χ^{m_i} span $\Gamma(X_{\Sigma}, \mathcal{O}_{X_{\Sigma}}(D))$, so that we can write ϕ_D as

$$(6.1.2) \quad \phi_D(p) = (\chi^{m_1}(p), \dots, \chi^{m_s}(p)).$$

See (6.0.7) for a careful description of what this means. When we restrict to the torus T_N , ϕ_D is the map (2.1.2). Hence our general theory relates nicely with the more concrete approach used in Chapter 2.

Example 6.1.3. The fan for the Hirzebruch surface \mathcal{H}_2 is shown in Figure 3. Let

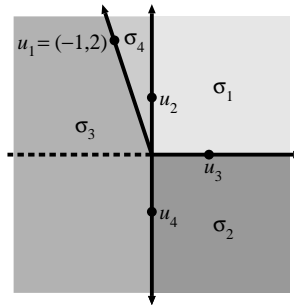

Figure 3. A fan Σ_2 with $X_{\Sigma_2} = \mathcal{H}_2$

D_i be the divisor corresponding to u_i . We will study the divisors

$$D = D_4 \quad \text{and} \quad D' = D_2 + D_4.$$

Write the Cartier data for D and D' with respect to $\sigma_1, \dots, \sigma_4$ as $\{m_i\}$ and $\{m'_i\}$ respectively. Figure 4 shows P_D and m_i (left) and $P_{D'}$ and m'_i (right) (see also

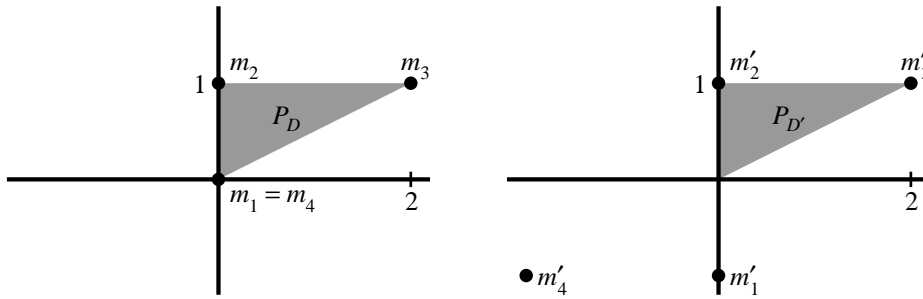

Figure 4. P_D and m_i (left) and $P_{D'}$ and m'_i (right)

Exercise 4.3.5). This figure and Proposition 6.1.2 make it clear that D is basepoint free while D' is not. \diamond

Very Ample Polytopes. Let $P \subseteq M_{\mathbb{R}} \simeq \mathbb{R}^n$ a full dimensional lattice polytope with facet presentation

$$P = \{m \in M_{\mathbb{R}} \mid \langle m, u_F \rangle \geq -a_F \text{ for all facets } F\}.$$

This gives the complete normal fan Σ_P and the toric variety X_P . Write

$$P \cap M = \{m_1, \dots, m_s\}.$$

A vertex $m_i \in P$ corresponds to a maximal cone

$$(6.1.3) \quad \sigma_i = \text{Cone}(P \cap M - m_i)^\vee \in \Sigma_P(n).$$

Proposition 4.2.10 implies that $D_P = \sum_F a_F D_F$ is Cartier since $\langle m_i, u_F \rangle = -a_F$ when $m_i \in F$.

Recall from Definition 2.2.16 that P is *very ample* if for every vertex $m_i \in P$, the semigroup $\mathbb{N}(P \cap M - m_i)$ is saturated in M . The definition of X_P given in Chapter 2 used very ample polytopes. This is no accident.

Proposition 6.1.4. *Let X_P and D_P be as above. Then:*

- (a) D_P is ample and basepoint free.
- (b) If $n \geq 2$, then kD_P is very ample for every $k \geq n - 1$.
- (c) D_P is very ample if and only if P is a very ample polytope.

Proof. First observe that the polytope of the divisor D_P is the polytope P we began with. Thus D_P is basepoint free by Proposition 6.1.2, which proves the final assertion of part (a). Furthermore, by (6.1.2), the map $\phi_{D_P} : X_P \rightarrow \mathbb{P}^{s-1}$ factors

$$X_P \rightarrow X_{P \cap M} \subseteq \mathbb{P}^{s-1},$$

where $X_{P \cap M}$ is the projective toric variety of $P \cap M \subseteq M$ from §2.3. We need to understand when $X_P \rightarrow X_{P \cap M}$ is an isomorphism.

Fix coordinates x_1, \dots, x_s of \mathbb{P}^{s-1} and let $I \subseteq \{1, \dots, s\}$ be the set of indices such that m_i is a vertex of P . Hence each $i \in I$ gives a vertex m_i and a corresponding maximal cone σ_i in the normal fan of P .

If $i \in I$, then $\langle m_i, u_F \rangle = -a_F$ for every facet F containing m_i . For all other facets F , $\langle m_i, u_F \rangle > -a_F$. Hence, if s_i is the global section corresponding to χ^{m_i} , then the support of $\text{div}(s_i)_0 = D + \text{div}(\chi^{m_i})$ consists of those divisors missing the affine open toric variety $U_{\sigma_i} \subseteq X_P$ of σ_i . It follows that U_{σ_i} is the nonvanishing locus of s_i .

Under the map ϕ_D , this nonvanishing locus maps to the affine open subset $U_i \subseteq \mathbb{P}^{s-1}$ where $x_i \neq 0$. Since $X_P = \bigcup_{i \in I} U_{\sigma_i}$ and $X_{P \cap M} \subseteq \bigcup_{i \in I} U_i$, it suffices to study the maps

$$U_{\sigma_i} \longrightarrow X_{P \cap M} \cap U_i$$

of affine toric varieties. By Proposition 2.1.8,

$$X_{P \cap M} \cap U_i = \text{Spec}(\mathbb{C}[\mathbb{N}(P \cap M - m_i)]).$$

Since $\sigma_i^\vee = \text{Cone}(P \cap M - m_i)$ by (6.1.3), we have an inclusion of semigroups

$$\mathbb{N}(P \cap M - m_i) \subseteq \sigma_i^\vee \cap M.$$

This is an equality precisely when $\mathbb{N}(P \cap M - m_i)$ is saturated in M . Since $U_{\sigma_i} = \text{Spec}(\mathbb{C}[\sigma_i^\vee \cap M])$, we obtain the equivalences:

$$\begin{aligned} D_P \text{ is very ample} &\iff X_P \rightarrow X_{P \cap M} \text{ is an isomorphism} \\ &\iff U_{\sigma_i} \rightarrow X_{P \cap M} \cap U_i \text{ is an isomorphism for all } i \in I \\ &\iff \mathbb{C}[\mathbb{N}(P \cap M - m_i)] \rightarrow \mathbb{C}[\sigma_i^\vee \cap M] \text{ is an} \\ &\quad \text{isomorphism for all } i \in I \\ &\iff \mathbb{N}(P \cap M - m_i) \text{ is saturated for all } i \in I \\ &\iff P \text{ is very ample.} \end{aligned}$$

This proves part (c) of the proposition. For part (b), recall that if $n \geq 2$ and P is arbitrary, then kP is very ample when $k \geq n - 1$ by Corollary 2.2.18. Hence $kD_P = D_{kP}$ is very ample. This implies that D_P is ample (the case $n = 1$ is trivial), which completes the proof of part (a). \square

Example 6.1.5. In Example 2.2.10, we showed that

$$P = \text{Conv}(0, e_1, e_2, e_1 + e_2 + 3e_3) \subseteq \mathbb{R}^3$$

is not normal. We show that P is not very ample as follows. From Chapter 2 we know that the only lattice points of P are its vertices, so that $\phi_{D_P} : X_P \rightarrow \mathbb{P}^3$. Since X_P is singular (Exercise 6.1.1) of dimension 3, it follows that ϕ_{D_P} cannot be a closed embedding. Hence P and D_P are not very ample. However, $2P$ and $2D_P$ are very ample by Proposition 6.1.4. \diamond

Support Functions and Convexity. Let $D = \sum_{\rho} a_{\rho} D_{\rho}$ be a Cartier divisor on a complete toric variety X_{Σ} . As in Chapter 4, its *support function* $\varphi_D : N_{\mathbb{R}} \rightarrow \mathbb{R}$ is determined by the following properties:

- φ_D is linear on each cone $\sigma \in \Sigma$.
- $\varphi_D(u_{\rho}) = -a_{\rho}$ for all $\rho \in \Sigma(1)$.

This is where the $\{m_{\sigma}\}_{\sigma \in \Sigma}$ from (6.1.1) appear naturally, since the explicit formula for $\varphi_D|_{\sigma}$ is given by $\varphi_D(u) = \langle m_{\sigma}, u \rangle$ for all $u \in \sigma$.

When $M = \mathbb{Z}^2$, it is easy to visualize the graph of φ_D in $M_{\mathbb{R}} \times \mathbb{R} = \mathbb{R}^3$: imagine a tent, with centerpole extending from $(0, 0, 0)$ down the z -axis, and tent stakes placed at positions $(u_{\rho}, -a_{\rho})$. Here is an example.

Example 6.1.6. Take $\mathbb{P}^1 \times \mathbb{P}^1$ and consider the divisor $D = D_1 + D_2 + D_3 + D_4$. This gives the support function where $\varphi_D(u_i) = -1$ for the four ray generators u_1, u_2, u_3, u_4 of the fan of $\mathbb{P}^1 \times \mathbb{P}^1$. The graph of φ_D is shown in Figure 5. This

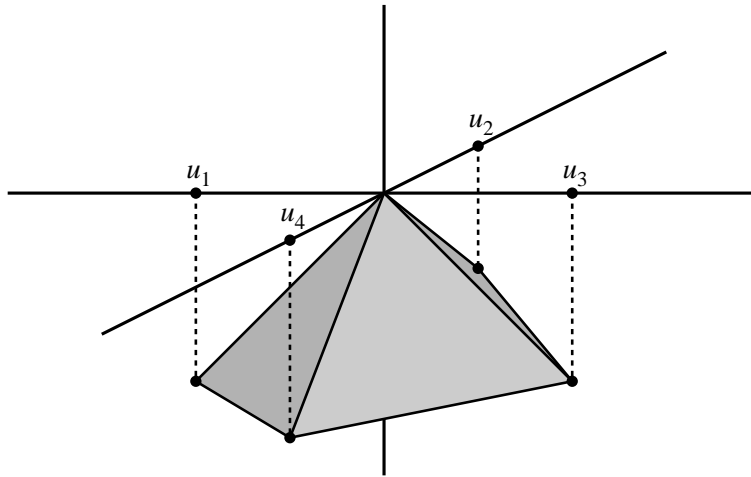

Figure 5. The graph of φ_D

should be visualized as an infinite Egyptian pyramid, with apex at the origin and edges going through $(u_i, -1)$ for $1 \leq i \leq 4$. \diamond

The first key concept of this section was ampleness. The second is convexity.

Definition 6.1.7. Let $S \subseteq N_{\mathbb{R}}$ be convex. A function $\varphi : S \rightarrow \mathbb{R}$ is **convex** if

$$\varphi(tu + (1-t)v) \geq t\varphi(u) + (1-t)\varphi(v),$$

for all $u, v \in S$ and $t \in [0, 1]$.

Continuing with the tent analogy, a support function φ_D is convex exactly if there are unimpeded lines of sight inside the tent. It is clear that for Example 6.1.6, the support function is convex.

The following lemma will help us understand what it means for a support function to be convex. Given a fan Σ in $N_{\mathbb{R}} \simeq \mathbb{R}^n$, a cone $\tau \in \Sigma(n-1)$ is called a *wall* when it is the intersection of two n -dimensional cones $\sigma, \sigma' \in \Sigma(n)$, i.e, when $\tau = \sigma \cap \sigma'$ forms the wall separating σ and σ' .

Lemma 6.1.8. *For the support function φ_D , the following are equivalent:*

- (a) φ_D is convex.
- (b) $\varphi_D(u) \leq \langle m_{\sigma}, u \rangle$ for all $u \in N_{\mathbb{R}}$ and $\sigma \in \Sigma(n)$.
- (c) $\varphi_D(u) = \min_{\sigma \in \Sigma(n)} \langle m_{\sigma}, u \rangle$ for all $u \in N_{\mathbb{R}}$.
- (d) For every wall $\tau = \sigma \cap \sigma'$, there is $u_0 \in \sigma' \setminus \sigma$ with $\varphi_D(u_0) \leq \langle m_{\sigma}, u_0 \rangle$.

Proof. First assume (a) and fix v in the interior of $\sigma \in \Sigma(n)$. Given $u \in N_{\mathbb{R}}$, we can find $t \in (0, 1)$ such that $tu + (1-t)v \in \sigma$. By convexity, we have

$$\begin{aligned} \langle m_{\sigma}, tu + (1-t)v \rangle &= \varphi_D(tu + (1-t)v) \\ &\geq t\varphi_D(u) + (1-t)\varphi_D(v) = t\varphi_D(u) + (1-t)\langle m_{\sigma}, v \rangle. \end{aligned}$$

This easily implies $\langle m_{\sigma}, u \rangle \geq \varphi_D(u)$, proving (b). The implication (b) \Rightarrow (c) is immediate since $\varphi_D(u) = \langle m_{\sigma}, u \rangle$ for $u \in \sigma$, and (c) \Rightarrow (a) follows because the minimum of a finite set of linear functions is always convex (Exercise 6.1.2).

Since (b) \Rightarrow (d) is obvious, it remains to prove the converse. Assume (d) and fix a wall $\tau = \sigma \cap \sigma'$. Then σ' lies on one side of the wall. We claim that

$$(6.1.4) \quad \langle m_{\sigma'}, u \rangle \leq \langle m_{\sigma}, u \rangle, \quad \text{when } u, \sigma' \text{ are on the same side of } \tau.$$

This is easy. The wall is defined by $\langle m_{\sigma} - m_{\sigma'}, u \rangle = 0$. Then (d) implies that the halfspace containing σ' is defined by $\langle m_{\sigma} - m_{\sigma'}, u \rangle \geq 0$, and (6.1.4) follows.

Now take $u \in N_{\mathbb{R}}$ and $\sigma \in \Sigma(n)$. We can pick v in the interior of σ so that the line segment \overline{uv} intersects every wall of Σ in a single point, as shown in Figure 6 on the next page. Using (6.1.4) repeatedly, we obtain

$$\langle m_{\sigma}, u \rangle \geq \langle m_{\sigma'}, u \rangle \geq \langle m_{\sigma''}, u \rangle \geq \dots$$

When we arrive at the cone containing u , the pairing becomes $\varphi_D(u)$, so that $\langle m_{\sigma}, u \rangle \geq \varphi_D(u)$. This proves (b). \square

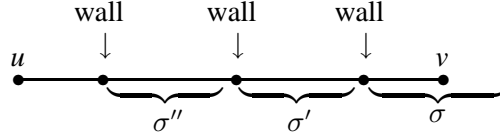

Figure 6. Crossing walls from u to v along \overline{uv}

In terms of the tent analogy, part (b) of the lemma means that if we have a convex support function and extend one side of the tent in all directions, the rest of the tent lies below the resulting hyperplane. Then part (d) means that it suffices to check this locally where two sides of the tent meet.

The proof of our main result about convexity will use the following lemma that describes the polyhedron of a Cartier divisor in terms of its support function.

Lemma 6.1.9. *Let Σ be a fan and $D = \sum_{\rho} a_{\rho} D_{\rho}$ be a Cartier divisor on X_{Σ} . Then*

$$P_D = \{m \in M_{\mathbb{R}} \mid \varphi_D(u) \leq \langle m, u \rangle \text{ for all } u \in |\Sigma|\}.$$

Proof. Assume $\varphi_D(u) \leq \langle m, u \rangle$ for all $u \in |\Sigma|$. Applying this with $u = u_{\rho}$ gives

$$-a_{\rho} = \varphi_D(u_{\rho}) \leq \langle m, u_{\rho} \rangle,$$

so that $m \in P_D$ by the definition of P_D . For the opposite inclusion, take $m \in P_D$ and $u \in |\Sigma|$. Thus $u \in \sigma \in \Sigma$, so that $u = \sum_{\rho \in \sigma(1)} \lambda_{\rho} u_{\rho}$, $\lambda_{\rho} \geq 0$. Then

$$\begin{aligned} \langle m, u \rangle &= \sum_{\rho \in \sigma(1)} \lambda_{\rho} \langle m, u_{\rho} \rangle \geq \sum_{\rho \in \sigma(1)} \lambda_{\rho} (-a_{\rho}) \\ &= \sum_{\rho \in \sigma(1)} \lambda_{\rho} \varphi_D(u_{\rho}) = \varphi_D(u), \end{aligned}$$

where the inequality follows from $m \in P_D$, and the last two equalities follow from the defining properties of φ_D . \square

We now expand Proposition 6.1.2 to give a more complete characterization of when a divisor is basepoint free.

Theorem 6.1.10. *Assume Σ is complete and let φ_D be the support function of a Cartier divisor $D = \sum_{\rho} a_{\rho} D_{\rho}$ on X_{Σ} . Then the following are equivalent:*

- D is basepoint free.
- $m_{\sigma} \in P_D$ for all $\sigma \in \Sigma(n)$.
- $P_D = \text{Conv}(m_{\sigma} \mid \sigma \in \Sigma(n))$.
- $\{m_{\sigma} \mid \sigma \in \Sigma(n)\}$ is the set of vertices of P_D .
- $\varphi_D(u) = \min_{m \in P_D} \langle m, u \rangle$ for all $u \in N_{\mathbb{R}}$.
- $\varphi_D(u) = \min_{\sigma \in \Sigma(n)} \langle m_{\sigma}, u \rangle$ for all $u \in N_{\mathbb{R}}$.
- $\varphi_D : N_{\mathbb{R}} \rightarrow \mathbb{R}$ is convex.

Proof. The equivalences (a) \Leftrightarrow (b) and (f) \Leftrightarrow (g) were proved in Proposition 6.1.2 and Lemma 6.1.8. Furthermore, Lemmas 6.1.8 and 6.1.9 imply that

$$\begin{aligned} \varphi_D \text{ is convex} &\iff \varphi_D(u) \leq \langle m_\sigma, u \rangle \text{ for all } \sigma \in \Sigma(n), u \in N_{\mathbb{R}} \\ &\iff m_\sigma \in P_D \text{ for all } \sigma \in \Sigma(n). \end{aligned}$$

This proves (g) \Leftrightarrow (b), so that (a), (b), (f) and (g) are equivalent.

Assume (b). Then $m_\sigma \in P_D$ and $\varphi_D(u) = \min_{\sigma \in \Sigma(n)} \langle m_\sigma, u \rangle$. Combining these with Lemma 6.1.9, we obtain

$$\varphi_D(u) \leq \min_{m \in P_D} \langle m, u \rangle \leq \min_{\sigma \in \Sigma(n)} \langle m_\sigma, u \rangle = \varphi_D(u),$$

proving (e). The implication (e) \Rightarrow (g) follows since the minimum of a compact set of linear functions is convex (Exercise 6.1.2). So (a) \Leftrightarrow (b) \Leftrightarrow (e) \Leftrightarrow (f) \Leftrightarrow (g).

Consider (d). The implications (d) \Rightarrow (c) \Rightarrow (b) are clear. For (b) \Rightarrow (d), take $\sigma \in \Sigma(n)$. Let u be in the interior of σ and set $a = \varphi_D(u)$. By Exercise 6.1.3, $H_{u,a} = \{m \in M_{\mathbb{R}} \mid \langle m, u \rangle = a\}$ is a supporting hyperplane of P_D and

$$(6.1.5) \quad H_{u,a} \cap P_D = \{m_\sigma\}.$$

This implies that m_σ is a vertex of P_D . Conversely, let $H_{u,a}$ be a supporting hyperplane of a vertex $v \in P_D$. This means $\langle m, u \rangle \geq a$ for all $m \in P_D$, with equality if and only if $m = v$. Since (b) holds, we also have (e) and (f). By (e), $\varphi_D(u) = \min_{m \in P_D} \langle m, u \rangle = \langle m, v \rangle = a$. Combining this with (f), we obtain

$$\varphi_D(u) = \min_{\sigma \in \Sigma(n)} \langle m_\sigma, u \rangle = a.$$

Hence $\langle m_\sigma, u \rangle = a$ must occur for some $\sigma \in \Sigma(n)$, which forces $v = m_\sigma$. □

Example 6.1.11. In Example 6.1.3 we showed that on the Hirzebruch surface \mathcal{H}_2 , $D = D_4$ is basepoint free while $D' = D_2 + D_4$ is not. Theorem 6.1.10 gives a different proof using support functions. Figure 7 shows the graph of the support

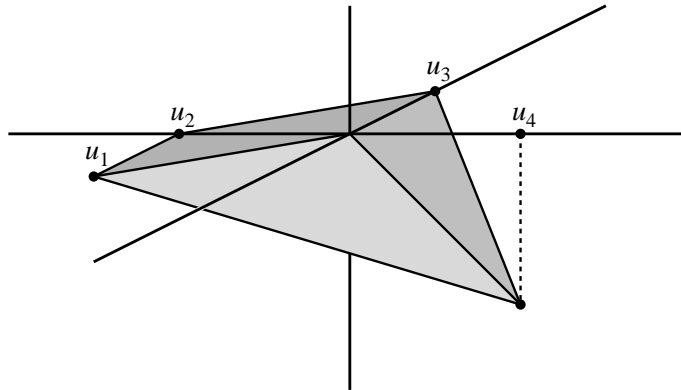

Figure 7. The graph of $\varphi_D = \varphi_{D_4}$

function φ_D . Notice that the portion of the “roof” containing the points u_1, u_2, u_3 and the origin lies in the plane $z = 0$, and it is clear that for φ_D , there are unimpeded lines of sight within the tent. In other words, φ_D is convex.

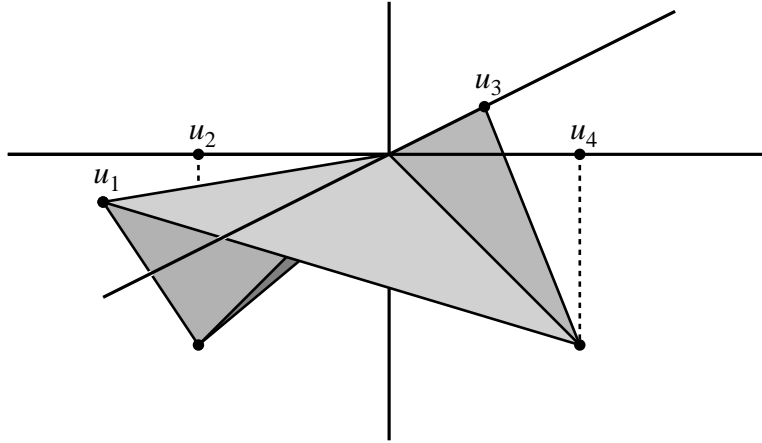

Figure 8. The graph of $\varphi_{D'} = \varphi_{D_2+D_4}$

The support function $\varphi_{D'}$ is shown in Figure 8. Here, the line of sight from u_1 to u_3 lies in the plane $z = 0$, yet the ridgeline going from the origin to the point $(u_2, -1)$ on the tent lies below the plane $z = 0$. Hence this line of sight does not lie inside the tent, so that $\varphi_{D'}$ is not convex. \diamond

When D is basepoint free, Theorem 6.1.10 implies that the vertices of P_D are the lattice points m_σ , $\sigma \in \Sigma(n)$. One caution is that in general, the m_σ need not be distinct, i.e., $\sigma \neq \sigma'$ can have $m_\sigma = m_{\sigma'}$. An example is given by the divisor $D = D_4$ considered in Example 6.1.3—see Figure 4. As we will see later, this behavior illustrates the difference between basepoint free and ample.

It can also happen that P_D has strictly smaller dimension than the dimension of X_Σ . You will work out a simple example of this in Exercise 6.1.4.

Ampleness and Strict Convexity. We next determine when a Cartier divisor $D = \sum_\rho a_\rho D_\rho$ on X_Σ is ample. The Cartier data $\{m_\sigma\}_{\sigma \in \Sigma(n)}$ of D satisfies

$$\langle m_\sigma, u \rangle = \phi_D(u), \quad \text{for all } u \in \sigma.$$

Definition 6.1.12. The support function φ_D of a Cartier divisor on X_Σ is **strictly convex** if it is convex and for every $\sigma \in \Sigma(n)$ satisfies

$$\langle m_\sigma, u \rangle = \varphi_D(u) \iff u \in \sigma.$$

There are many ways to think about strict convexity.

Lemma 6.1.13. *For the support function φ_D , the following are equivalent:*

- (a) φ_D is strictly convex.
- (b) $\varphi_D(u) < \langle m_\sigma, u \rangle$ for all $u \notin \sigma$ and $\sigma \in \Sigma(n)$.
- (c) For every wall $\tau = \sigma \cap \sigma'$, there is $u_0 \in \sigma' \setminus \sigma$ with $\varphi_D(u_0) < \langle m_\sigma, u_0 \rangle$.
- (d) φ_D is convex and $m_\sigma \neq m_{\sigma'}$ when $\sigma \neq \sigma'$ in $\Sigma(n)$ and $\sigma \cap \sigma'$ is a wall.
- (e) φ_D is convex and $m_\sigma \neq m_{\sigma'}$ when $\sigma \neq \sigma'$ in $\Sigma(n)$.
- (f) $\langle m_\sigma, u_\rho \rangle > -a_\rho$ for all $\rho \in \Sigma(1) \setminus \sigma(1)$ and $\sigma \in \Sigma(n)$.
- (g) $\varphi_D(u+v) > \varphi_D(u) + \varphi_D(v)$ for all $u, v \in N_{\mathbb{R}}$ not in the same cone of Σ .

Proof. You will prove this in Exercise 6.1.5. □

We now relate strict convexity to ampleness.

Theorem 6.1.14. *Assume that φ_D is the support function of a Cartier divisor $D = \sum_{\rho} a_{\rho} D_{\rho}$ on a complete toric variety X_{Σ} . Then*

$$D \text{ is ample} \iff \varphi_D \text{ is strictly convex.}$$

Furthermore, if $n \geq 2$ and D is ample, then kD is very ample for all $k \geq n - 1$.

Proof. First suppose that D is very ample. Very ample divisors have no basepoints, so φ_D is convex by Theorem 6.1.10. If strict convexity fails, then Lemma 6.1.13 implies that Σ has a wall $\tau = \sigma \cap \sigma'$ with $m_\sigma = m_{\sigma'}$. Let $V(\tau) = \overline{O(\tau)} \subseteq X_{\Sigma}$.

Let $P_D \cap M = \{m_1, \dots, m_s\}$, so that $\phi_D : X_{\Sigma} \rightarrow \mathbb{P}^{s-1}$ can be written

$$\phi_D(p) = (\chi^{m_1}(p), \dots, \chi^{m_s}(p))$$

as in (6.1.2). In this enumeration, $m_\sigma = m_{\sigma'} = m_{i_0}$ for some i_0 . We will study ϕ_D on the open subset $U_\sigma \cup U_{\sigma'} \subseteq X_{\Sigma}$.

First consider U_σ . Theorem 6.1.10 implies that $m_\sigma \in P_D$, so that the section corresponding to χ^{m_σ} is nonvanishing on U_σ by the proof of Proposition 6.1.2. It follows that on U_σ , ϕ_D is given by

$$\phi_D(p) = (\chi^{m_1 - m_\sigma}(p), \dots, \chi^{m_s - m_\sigma}(p)) \in U_{i_0} \simeq \mathbb{C}^{s-1},$$

where $U_{i_0} \subseteq \mathbb{P}^{s-1}$ is the open subset where $x_{i_0} \neq 0$.

Since $m_\sigma = m_{\sigma'}$, the same argument works on $U_{\sigma'}$. This gives a morphism

$$\phi_D|_{U_\sigma \cup U_{\sigma'}} : U_\sigma \cup U_{\sigma'} \longrightarrow U_{i_0} \simeq \mathbb{C}^{s-1}.$$

The only n -dimensional cones of Σ containing τ are σ, σ' since τ is a wall. Hence

$$V(\tau) \subset U_\sigma \cup U_{\sigma'}$$

by the Orbit-Cone Correspondence. Note also $V(\tau) \simeq \mathbb{P}^1$ since τ is a wall. Since \mathbb{P}^1 is complete, Proposition 4.3.8 implies that all morphisms from \mathbb{P}^1 to affine space are constant. Thus ϕ_D maps $V(\tau)$ to a point, which is impossible since D is very ample. Hence φ_D is strictly convex when D is very ample.

If D is ample, then kD is very ample for $k \gg 0$. Thus $\varphi_{kD} = k\varphi_D$ must be strictly convex, which implies that φ_D is strictly convex.

For the converse, assume φ_D is strictly convex. We first show that $P_D \subset M_{\mathbb{R}}$ is a full dimensional lattice polytope. Let $\{m_{\sigma}\}_{\sigma \in \Sigma(n)}$ be the Cartier data of D . Since φ is convex, Theorem 6.1.10 shows that the m_{σ} are the vertices of P_D . Hence P_D is a lattice polytope.

If P_D is not full dimensional, then there are $u \neq 0$ in $N_{\mathbb{R}}$ and $k \in \mathbb{R}$ such that $\langle m_{\sigma}, u \rangle = k$ for all $\sigma \in \Sigma(n)$. Then Theorem 6.1.10 implies

$$\varphi_D(u) = \langle m_{\sigma}, u \rangle = k$$

for all $\sigma \in \Sigma(n)$. Using strict convexity and Definition 6.1.12, we conclude that $u \in \sigma$ for all $\sigma \in \Sigma(n)$. Hence $u = 0$ since Σ is complete. This contradicts $u \neq 0$ and proves that P_D is full dimensional.

Hence P_D gives the toric variety X_{P_D} with normal fan Σ_{P_D} . Furthermore, X_{P_D} has the ample divisor D_{P_D} from Proposition 6.1.4. We studied the support function of this divisor in Proposition 4.2.14, where we showed that it is the function

$$\varphi_{P_D}(u) = \min_{m \in P_D} \langle m, u \rangle.$$

However, this is precisely φ_D by Theorem 6.1.10. Hence $\varphi_{P_D} = \varphi_D$ is strictly convex with respect to Σ (by hypothesis) and Σ_{P_D} (by the first part of the proof).

Definition 6.1.13 implies that the maximal cones of the fan are the maximal subsets of $N_{\mathbb{R}}$ on which a strictly convex support function is linear. This observation, combined with the previous paragraph, implies that $\Sigma = \Sigma_{P_D}$. Thus D_{P_D} is an ample divisor on $X_{\Sigma} = X_{P_D}$. We also have $D = D_{P_D}$ since the divisors have the same support function. It follows that D is ample.

The final assertion of the theorem also follows from Proposition 6.1.4. \square

Here is a corollary of the proof of Theorem 6.1.14.

Corollary 6.1.15. *Let D be an ample divisor on a complete toric variety X_{Σ} . Then P_D is a full dimensional lattice polytope, Σ is the normal fan of P_D , and D is the Cartier divisor associated to P_D .* \square

We have the following nice result in the smooth case.

Theorem 6.1.16. *On a smooth complete toric variety X_{Σ} , a divisor D is ample if and only if it is very ample.*

Proof. If D is ample, then Corollary 6.1.15 shows that Σ is the normal fan of P_D and D is the divisor of P_D . Since X_{Σ} is smooth, P_D is very ample by Theorem 2.4.3 and Proposition 2.4.4. Then we are done by Proposition 6.1.4. \square

Computing Ample Divisors. Given a wall $\tau \in \Sigma(n-1)$, write $\tau = \sigma \cap \sigma'$ and pick $\rho' \in \sigma'(1) \setminus \sigma(1)$. Then a Cartier divisor $D = \sum_{\rho} a_{\rho} D_{\rho}$ gives the *wall inequality*

$$(6.1.6) \quad \langle m_{\sigma}, u_{\rho'} \rangle > -a_{\rho'}.$$

Lemma 6.1.13 and Theorem 6.1.14 imply that D is ample if and only if it satisfies the wall inequality (6.1.6) for every wall of Σ .

In terms of divisor classes, recall the map $\text{CDiv}_T(X_{\Sigma}) \rightarrow \text{Pic}(X_{\Sigma})$ whose kernel consists of divisors of characters. If we fix $\sigma_0 \in \Sigma(n)$, then we have an isomorphism

$$(6.1.7) \quad \{D = \sum_{\rho} a_{\rho} D_{\rho} \in \text{CDiv}_T(X_{\Sigma}) \mid a_{\rho} = 0 \text{ for all } \rho \in \sigma_0(1)\} \simeq \text{Pic}(X_{\Sigma})$$

(Exercise 6.1.6). Then (6.1.6) gives inequalities for determining when a divisor class is ample. Here is a classic example.

Example 6.1.17. Let us determine the ample divisors on the Hirzebruch surface \mathcal{H}_r . The fan for \mathcal{H}_2 is shown in Figure 3 of Example 6.1.3, and this becomes the fan for \mathcal{H}_r by redefining u_1 to be $u_1 = (-1, r)$. Hence we have ray generators u_1, u_2, u_3, u_4 and maximal cones $\sigma_1, \sigma_2, \sigma_3, \sigma_4$.

In Examples 4.3.5 and 4.1.8, we used D_1 and D_2 to give a basis of $\text{Pic}(\mathcal{H}_r) = \text{Cl}(\mathcal{H}_r)$. Here, it is more convenient to use D_3 and D_4 . More precisely, applying (6.1.7) for the cone σ_4 , we obtain

$$\text{Pic}(\mathcal{H}_r) \simeq \{aD_3 + bD_4 \mid a, b \in \mathbb{Z}\}.$$

To determine when $aD_3 + bD_4$ is ample, we compute $m_i = m_{\sigma_i}$ to be

$$m_1 = (-a, 0), \quad m_2 = (-a, b), \quad m_3 = (rb, b), \quad m_4 = (0, 0).$$

Then (6.1.6) gives four wall inequalities which reduce to $a, b > 0$. Thus

$$(6.1.8) \quad aD_3 + bD_4 \text{ is ample} \iff a, b > 0.$$

For an arbitrary divisor $D = \sum_{i=1}^4 a_i D_i$, the relations

$$\begin{aligned} 0 &\sim \text{div}(\chi^{e_1}) = -D_1 + D_3 \\ 0 &\sim \text{div}(\chi^{e_2}) = rD_1 + D_2 - D_4 \end{aligned}$$

show that $D \sim (a_1 - ra_2 + a_3)D_3 + (a_2 + a_4)D_4$. Hence

$$\sum_{i=1}^4 a_i D_i \text{ is ample} \iff a_1 + a_3 > ra_2, \quad a_2 + a_4 > 0.$$

Sometimes ampleness is easier to check if we think geometrically in terms of support functions. For $D = aD_3 + bD_4$, look back at Figure 6 and imagine moving the vertex at u_3 downwards. This gives the graph of φ_D , which is strictly convex when $a, b > 0$. \diamond

Here is an example of how to determine ampleness using support functions.

Example 6.1.18. The fan for $\mathbb{P}^1 \times \mathbb{P}^1 \times \mathbb{P}^1$ has the eight orthants of \mathbb{R}^3 as its maximal cones, and the ray generators are $\pm e_1, \pm e_2, \pm e_3$. Take the positive orthant $\mathbb{R}_{\geq 0}^3$ and subdivide further by adding the new ray generators

$$a = (2, 1, 1), \quad b = (1, 2, 1), \quad c = (1, 1, 2), \quad d = (1, 1, 1).$$

We obtain a complete fan Σ by filling the first orthant with the cones in Figure 9, which shows the intersection of $\mathbb{R}_{\geq 0}^3$ with the plane $x + y + z = 1$. You will check that Σ is smooth in Exercise 6.1.7.

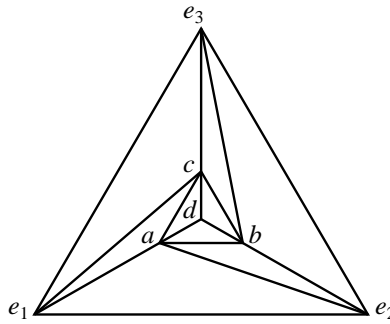

Figure 9. Cones of Σ lying in $\mathbb{R}_{\geq 0}^3$

Let $D = \sum_{\rho} a_{\rho} D_{\rho}$ be a Cartier divisor on X_{Σ} . Replacing D with $D + \operatorname{div}(\chi^m)$ for $m = (-a_{e_1}, -a_{e_2}, -a_{e_3})$, we can assume that φ_D satisfies

$$\varphi_D(e_1) = \varphi_D(e_2) = \varphi_D(e_3) = 0.$$

Now observe that $e_1 + b = (2, 2, 1) = e_2 + a$. Since e_1 and b do not lie in a cone of Σ , part (g) of Lemma 6.1.13 implies that

$$\varphi_D(e_1 + b) > \varphi_D(e_1) + \varphi_D(b) = \varphi_D(b).$$

However, e_2 and a generate a cone of Σ , so that

$$\varphi_D(a) = \varphi_D(e_2) + \varphi_D(a) = \varphi_D(e_2 + a) = \varphi_D(e_1 + b).$$

Together, these imply $\varphi_D(a) > \varphi_D(b)$. By symmetry, we obtain

$$\varphi_D(a) > \varphi_D(b) > \varphi_D(c) > \varphi_D(a),$$

an impossibility. Hence there are no strictly convex support functions. This proves that X_{Σ} is a smooth complete nonprojective variety. \diamond

The Toric Chow Lemma. Recall from Chapter 3 that if Σ' is a refinement of Σ , then there is a proper birational toric morphism $X_{\Sigma'} \rightarrow X_{\Sigma}$. We will now use the methods of this section to prove the *Toric Chow Lemma*, which asserts that fans such as the one described in Example 6.1.18 always have refinements that give projective toric varieties. Here is the precise result.

Theorem 6.1.19. *A complete fan Σ has a refinement Σ' such that $X_{\Sigma'}$ is projective.*

Proof. Suppose Σ is a fan in $N_{\mathbb{R}} \simeq \mathbb{R}^n$. Let Σ' be obtained from Σ by considering the complete fan obtained from

$$\bigcup_{\tau \in \Sigma(n-1)} \text{Span}(\tau).$$

So for each wall τ , we take the entire hyperplane spanned by the wall. This yields a subdivision Σ' with the property that

$$\bigcup_{\tau' \in \Sigma'(n-1)} \tau' = \bigcup_{\tau \in \Sigma(n-1)} \text{Span}(\tau),$$

i.e., each hyperplane $\text{Span}(\tau)$ is a union of walls of Σ' , and all walls of Σ' arise this way.

Choosing $m_{\tau} \in M$ so that

$$\{u \in N_{\mathbb{R}} \mid \langle m_{\tau}, u \rangle = 0\} = \text{Span}(\tau),$$

define the map $\varphi : N_{\mathbb{R}} \rightarrow \mathbb{R}$ by

$$\varphi(u) = - \sum_{\tau \in \Sigma(n-1)} |\langle m_{\tau}, u \rangle|.$$

Note that φ takes integer values on N and is convex by the triangle inequality (this explains the minus sign).

Let us show that φ is piecewise linear with respect to Σ' . Fix $\tau \in \Sigma(n-1)$ and note that each cone of Σ' is contained in one of the closed half-spaces bounded by $\text{Span}(\tau)$. This implies that $u \mapsto |\langle m_{\tau}, u \rangle|$ is linear on each cone of Σ' . Hence the same is true for φ .

Finally, we prove that φ is strictly convex. Suppose that $\tau' = \sigma'_1 \cap \sigma'_2$ is a wall of Σ' . Then $\tau' \subseteq \text{Span}(\tau_0)$, $\tau_0 \in \Sigma(n-1)$. We label σ'_1 and σ'_2 so that

$$\begin{aligned} \varphi|_{\sigma'_1}(u) &= -\langle m_{\tau_0}, u \rangle - \sum_{\tau \neq \tau_0 \text{ in } \Sigma(n-1)} |\langle m_{\tau}, u \rangle|, \quad u \in \sigma'_1 \\ \varphi|_{\sigma'_2}(u) &= \langle m_{\tau_0}, u \rangle - \sum_{\tau \neq \tau_0 \text{ in } \Sigma(n-1)} |\langle m_{\tau}, u \rangle|, \quad u \in \sigma'_2. \end{aligned}$$

The sum $\sum_{\tau \neq \tau_0 \text{ in } \Sigma(n-1)} |\langle m_{\tau}, u \rangle|$ is linear on $\sigma'_1 \cup \sigma'_2$, so φ is represented by different linear functions on each side of the wall τ' . Since φ is convex, it is strictly convex by Lemma 6.1.13. Then $X_{\Sigma'}$ is projective since $D' = -\sum_{\rho'} \varphi(u_{\rho'}) D_{\rho'}$ is ample by Theorem 6.1.14. \square

In Chapter 11 we will improve this result by showing that $X_{\Sigma'}$ can be chosen to be smooth and projective.

Pulling Back by Toric Morphisms. The final topic of this section is a study of basepoint free divisors that are not ample. Our results will need the following description of pullbacks of torus-invariant Cartier divisors by toric morphisms.

Proposition 6.1.20. *Assume that $\phi : X_{\Sigma_1} \rightarrow X_{\Sigma_2}$ is the toric morphism induced by $\bar{\phi} : N_1 \rightarrow N_2$, and let D_2 be a torus-invariant Cartier divisor with support function $\varphi_{D_2} : |\Sigma_2| \rightarrow \mathbb{R}$. Then there is a unique torus-invariant Cartier divisor D_1 on X_{Σ_1} with the following properties:*

- (a) $\mathcal{O}_{X_{\Sigma_1}}(D_1) \simeq \phi^* \mathcal{O}_{X_{\Sigma_2}}(D_2)$.
- (b) The support function φ_{D_1} is the composition

$$|\Sigma_1| \xrightarrow{\bar{\phi}} |\Sigma_2| \xrightarrow{\varphi_{D_2}} \mathbb{R}.$$

Proof. Let the local data of D_2 be $\{(U_\sigma, \chi^{-m_\sigma})\}_{\sigma \in \Sigma_2}$, where σ now refers to an arbitrary cone of Σ_2 . Recall that the minus sign comes from $\langle m_\sigma, u_\rho \rangle = -a_\rho$ when $\rho \in \sigma(1)$. Then the proof of Theorem 6.0.18 shows that $\mathcal{O}_{X_{\Sigma_2}}(D_2)$ is the sheaf of sections of a rank 1 vector bundle $V \rightarrow X_{\Sigma_2}$ with transition functions

$$g_{\sigma\tau} = \chi^{m_\tau - m_\sigma}.$$

Now take $\sigma' \in \Sigma_1$ and let $\sigma \in \Sigma_2$ be the smallest cone satisfying $\bar{\phi}_\mathbb{R}(\sigma') \subseteq \sigma$. Using the dual map $\bar{\phi}^* : M_2 \rightarrow M_1$, we set

$$m_{\sigma'} = \bar{\phi}^*(m_\sigma).$$

Since $\phi(U_{\sigma'}) \subseteq U_\sigma$, one can show without difficulty that

$$g_{\sigma'\tau'} = \chi^{m_{\tau'} - m_{\sigma'}} \in \mathcal{O}_{X_{\Sigma_1}}(U_{\sigma'} \cap U_{\tau'})^*.$$

Then $\{(U_{\sigma'}, \chi^{-m_{\sigma'}})\}_{\sigma' \in \Sigma_1}$ is the local data for a Cartier divisor D_1 on X_{Σ_1} . It is straightforward to verify that D_1 has the required properties (Exercise 6.1.8). \square

In the situation of Proposition 6.1.20, we call D_1 is the *pullback* of D_2 via ϕ since $\mathcal{O}_{X_{\Sigma_1}}(D_1)$ is the pullback of $\mathcal{O}_{X_{\Sigma_2}}(D_2)$ via ϕ .

The Toric Variety of a Basepoint Free Divisor. If $D = \sum_\rho a_\rho D_\rho$ has no basepoints, then P_D is a lattice polytope with the m_σ , $\sigma \in \Sigma(n)$, as vertices. In the ample case, we know from Corollary 6.1.15 that X_Σ is the toric variety of P_D . When D is merely basepoint free, the situation is more complicated but nevertheless quite lovely.

We begin with the normal fan of P_D . Since $P_D \subseteq M_\mathbb{R}$ may fail to be full dimensional, we need to explain what “normal fan” means in this context. Consider

$$M_D = \text{Span}(m - m' \mid m, m' \in P_D \cap M) \cap M \subseteq M,$$

with dual $N_D = \text{Hom}_\mathbb{Z}(M_D, \mathbb{Z})$. The inclusion $M_D \subseteq M$ induces a surjective homomorphism $\bar{\phi} : N \rightarrow N_D$ since M_D is saturated in M .

Translating P_D by a lattice point of $P_D \cap M$, we get a full dimensional lattice polytope $P_D \subseteq (M_D)_\mathbb{R}$. Hence we have:

- The normal fan of P_D in $(N_D)_{\mathbb{R}}$, which we write as $\Sigma_D = \Sigma_{P_D}$.
- The toric variety of P_D , which we write as $X_D = X_{P_D}$.

The construction of Σ_D and X_D are independent of how we translate P_D .

We can relate Σ_D to the given fan Σ as follows.

Proposition 6.1.21. *Let $D = \sum_{\rho} a_{\rho} D_{\rho}$ be a basepoint free Cartier divisor on X_{Σ} with polytope P_D . If $m \in P_D$ is a vertex and σ_m is the corresponding cone in the normal fan Σ_D , then*

$$\overline{\phi}_{\mathbb{R}}^{-1}(\sigma_m) = \bigcup_{\substack{\sigma \in \Sigma(n) \\ m_{\sigma} = m}} \sigma.$$

Proof. We first give an alternate description of $\overline{\phi}_{\mathbb{R}}^{-1}(\sigma_m)$. In the discussion of normal fans in §2.3, we saw that the vertex $m \in P_D \subseteq (M_D)_{\mathbb{R}}$ gives the cone

$$C_m = \text{Cone}(P_D \cap M_D - m) \subseteq (M_D)_{\mathbb{R}}$$

whose dual in $(N_D)_{\mathbb{R}}$ is σ_m . Since $M_D \subseteq M$ and $P_D \cap M_D = P_D \cap M$, we also have

$$C_m = \text{Cone}(P_D \cap M - m) \subseteq M_{\mathbb{R}}$$

whose dual in $N_{\mathbb{R}}$ is

$$(6.1.9) \quad C_m^{\vee} = \text{Cone}(P_D \cap M - m)^{\vee} = \overline{\phi}_{\mathbb{R}}^{-1}(\sigma_m).$$

This has some nice consequences. First, since C_m is strongly convex, (6.1.9) implies that $\overline{\phi}_{\mathbb{R}}^{-1}(\sigma_m)$ is a closed convex cone of dimension n in $N_{\mathbb{R}}$. It follows that the proposition is equivalent to the assertion

$$(6.1.10) \quad \text{for all } \sigma \in \Sigma(n), \text{Int}(\sigma) \cap \text{Int}(\overline{\phi}_{\mathbb{R}}^{-1}(\sigma_m)) \neq \emptyset \text{ implies } m_{\sigma} = m,$$

where ‘‘Int’’ denotes the interior (Exercise 6.1.9).

A second consequence of (6.1.9) is that any $u \in \overline{\phi}_{\mathbb{R}}^{-1}(\sigma_m)$ satisfies

$$\langle m' - m, u \rangle \geq 0, \quad \text{for all } m' \in P_D \cap M.$$

In particular, basepoint free implies $m_{\sigma} \in P_D$ for $\sigma \in \Sigma(n)$, so that

$$(6.1.11) \quad \langle m_{\sigma}, u \rangle \geq \langle m, u \rangle, \quad \text{for all } \sigma \in \Sigma(n).$$

We now prove (6.1.10). Assume $\text{Int}(\sigma) \cap \text{Int}(\overline{\phi}_{\mathbb{R}}^{-1}(\sigma_m)) \neq \emptyset$ and let u be an element of the intersection. Since $m = m_{\sigma'}$ for some $\sigma' \in \Sigma(n)$, we have

$$\langle m, u \rangle \geq \varphi_D(u) = \langle m_{\sigma}, u \rangle$$

by convexity and part (b) of Lemma 6.1.8. Combining this with (6.1.11), we see that

$$\langle m_{\sigma}, u \rangle = \langle m, u \rangle, \quad \text{for all } u \in \text{Int}(\sigma) \cap \text{Int}(\overline{\phi}_{\mathbb{R}}^{-1}(\sigma_m)).$$

Since $\text{Int}(\sigma) \cap \text{Int}(\overline{\phi}_{\mathbb{R}}^{-1}(\sigma_m))$ is open, this forces $m = m_{\sigma}$, proving (6.1.10). \square

This proposition gives a nice way to think about the fan Σ_D . One begins with the Cartier data $\{m_\sigma\}_{\sigma \in \Sigma(n)}$ of D and then combines all cones $\sigma \in \Sigma(n)$ whose m_σ 's give the same vertex of P_D . As we range over the vertices of P_D , these combined cones and their faces satisfy the conditions for being a fan, except that they may fail to be strongly convex. But they all contain the same maximal subspace, namely the kernel of $\bar{\phi}_\mathbb{R} : N_\mathbb{R} \rightarrow (N_D)_\mathbb{R}$. This is an example of what is called a *degenerate fan*. Once we mod out by the kernel, we get the genuine fan Σ_D in $(N_D)_\mathbb{R}$.

Proposition 6.1.21 makes it clear that $\bar{\phi} : N \rightarrow N_D$ is compatible with the fans Σ and Σ_D . This gives a toric morphism $X_\Sigma \rightarrow X_D$. We now prove that D is the pullback an ample divisor on X_D .

Theorem 6.1.22. *Let D be a basepoint free Cartier divisor on a complete toric variety, and let X_D be the toric variety of the polytope $P_D \subseteq M_\mathbb{R}$. Then the above toric morphism $\phi : X_\Sigma \rightarrow X_D$ is proper and D is linearly equivalent to the pullback of the ample divisor on X_D coming from P_D .*

Proof. First note that ϕ is proper since X_Σ and X_D are complete. Also recall that the sublattice $M_D \subseteq M$ is dual to $\bar{\phi} : N \rightarrow N_D$ and that we translate P_D so that it lies in $(M_D)_\mathbb{R}$. This changes our original divisor D by a linear equivalence.

The polytope P_D gives the ample divisor $\bar{D} = D_{P_D}$ on X_D . Since D is basepoint free, Theorem 6.1.10 implies that

$$\varphi_D(u) = \min_{m \in P_D} \langle m, u \rangle.$$

Using $P_D \subseteq (M_D)_\mathbb{R}$, one sees that φ_D factors through $\bar{\phi} : N \rightarrow N_D$, and in fact,

$$\varphi_D = \varphi_{\bar{D}} \circ \bar{\phi}_\mathbb{R}$$

(Exercise 6.1.10). By Proposition 6.1.20, D is the pullback of $\bar{D} = D_{P_D}$. \square

This theorem implies that any Cartier divisor without basepoints on a complete toric variety is linearly equivalent to the pullback (via a toric morphism) of an ample divisor on a projective toric variety of possibly smaller dimension.

Here are two examples to illustrate what can happen in Theorem 6.1.22.

Example 6.1.23. While the toric variety X_Σ of Example 6.1.18 has no ample divisors, it does have basepoint free divisors. The ray generators of Σ are

$$\pm e_1, \pm e_2, \pm e_3, a, b, c, d,$$

with corresponding toric divisors

$$D_1^\pm, D_2^\pm, D_3^\pm, D_a, D_b, D_c, D_d.$$

Then one can show that

$$D = 2D_1^- + 2D_2^- + 2D_3^- - D_a - D_b - D_c - D_d$$

is basepoint free (Exercise 6.1.7). Thus the support function φ_D is convex.

Figure 9 in Example 6.1.18 shows that $\text{Cone}(e_1, e_2, d)$ is a union of three cones of Σ . Using $\varphi_D(e_1) = \varphi_D(e_2) = 0$ and $\varphi_D(a) = \varphi_D(b) = \varphi_D(d) = 1$, one sees that these three cones all have $m_\sigma = e_3$ (Exercise 6.1.7). Hence we should combine these three cones. The same thing happens in $\text{Cone}(e_1, e_3, d)$ and $\text{Cone}(e_2, e_3, d)$.

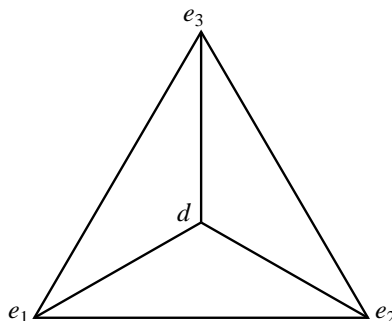

Figure 10. Combined cones of Σ lying in $\mathbb{R}_{\geq 0}^3$

Thus, in the first orthant, the fan of X_D looks like Figure 10 when intersected with $x + y + z = 1$. Hence X_D is the blowup of $(\mathbb{P}^1)^3$ at the point corresponding to the first orthant (Exercise 6.1.7). Note also that $\phi : X_\Sigma \rightarrow X_D$ is a proper birational toric morphism since Σ refines the fan of X_D . \diamond

Example 6.1.24. Consider the divisor $D = D_1$ on the Hirzebruch surface \mathcal{H}_2 , where we are using the notation of Example 6.1.3. For this divisor, the four cones $\sigma_1, \sigma_2, \sigma_3, \sigma_4$ of this fan give

$$m_{\sigma_1} = m_{\sigma_2} = 0, \quad m_{\sigma_3} = m_{\sigma_4} = e_1,$$

so that P_D is a line segment. When we combine σ_1, σ_2 and σ_3, σ_4 , Figure 3 from Example 6.1.3 shows that we get a degenerate fan. To get a genuine fan, we collapse the vertical axis and obtain the fan for $X_D = \mathbb{P}^1$. Here, $\phi : X_\Sigma \rightarrow X_D$ is the toric morphism from Example 3.3.5. \diamond

Exercises for §6.1.

6.1.1. Show that the toric variety X_P of the polytope P in Example 6.1.5 is singular.

6.1.2. Let $S \subseteq M_{\mathbb{R}}$ be a compact set and define $\phi : N_{\mathbb{R}} \rightarrow \mathbb{R}$ by $\phi(u) = \min_{m \in S} \langle m, u \rangle$. Explain carefully why the minimum exists and prove that ϕ is convex.

6.1.3. Let $H_{u,a}$ be as in the proof of (b) \Rightarrow (d). Prove that $H_{u,a}$ is a supporting hyperplane of P_D that satisfies (6.1.5). Hint: Write $u = \sum_{\rho \in \sigma(1)} \lambda_\rho u_\rho$, $\lambda_\rho > 0$. Then show $m \in P_D$ implies $\langle m, u \rangle = \sum_{\rho \in \sigma(1)} \lambda_\rho \langle m, u_\rho \rangle \geq \varphi_D(u)$.

6.1.4. As noted in the text, the polytope P_D of a basepoint free Cartier divisor on a complete toric variety X_Σ can have dimension strictly less than $\dim X_\Sigma$. Here are some examples.

- (a) Let D be one of the four torus-invariant prime divisors on $\mathbb{P}^1 \times \mathbb{P}^1$. Show that P_D is a line segment.
- (b) Consider $(\mathbb{P}^1)^n$ and fix an integer d with $0 < d < n$. Find a basepoint free divisor D on $(\mathbb{P}^1)^n$ such that $\dim P_D = d$. Hint: See Exercise 6.1.12 below.

6.1.5. This exercise is devoted to proving that the statements (a)–(g) of Lemma 6.1.13 are equivalent. Many of the implications use Lemma 6.1.8.

- (a) Prove (a) \Leftrightarrow (b) and (c) \Leftrightarrow (d).
- (b) Prove (b) \Rightarrow (e) and (b) \Rightarrow (f) \Rightarrow (c).
- (c) Prove (c) \Rightarrow (b) by adapting the proof of (d) \Rightarrow (b) from Lemma 6.1.8.
- (d) Prove (b) \Leftrightarrow (g) and use the obvious implication (e) \Rightarrow (d) to complete the proof of the lemma.

6.1.6. Let X_Σ be the toric variety of a fan Σ in $N_{\mathbb{R}} \simeq \mathbb{R}^n$ and fix $\sigma_0 \in \Sigma(n)$. Prove that the natural map $\text{CDiv}_T(X_\Sigma) \rightarrow \text{Pic}(X_\Sigma)$ induces an isomorphism

$$\left\{ D = \sum_{\rho} a_{\rho} D_{\rho} \in \text{CDiv}_T(X_\Sigma) \mid a_{\rho} = 0 \text{ for all } \rho \in \sigma_0(1) \right\} \simeq \text{Pic}(X_\Sigma).$$

6.1.7. This exercise deals with Examples 6.1.18 and 6.1.23.

- (a) Prove that the toric variety X_Σ of Example 6.1.18 is smooth.
- (b) Let $D = 2D_1^- + 2D_2^- + 2D_3^- - D_a - D_b - D_c - D_d$ be the divisor defined in Example 6.1.23. Prove that P_D is the polytope with 10 vertices
- $$e_1, e_2, e_3, 2e_1, 2e_2, 2e_3, 2e_1 + 2e_2, 2e_1 + 2e_3, 2e_2 + 2e_3, 2e_1 + 2e_2 + 2e_3$$
- and conclude that D is basepoint free.
- (c) In Example 6.1.23, we asserted that certain maximal cones of Σ must be combined to get the maximal cones of Σ_D . Prove that this is correct.
- (d) Show that X_D is the blowup of $(\mathbb{P}^1)^3$ at the point corresponding to the first orthant.

6.1.8. Complete the proof of Proposition 6.1.20.

6.1.9. Prove (6.1.10).

6.1.10. Complete the proof of Proposition 6.1.22.

6.1.11. For the following toric varieties X_Σ , compute $\text{Pic}(X_\Sigma)$ and describe which torus-invariant divisors are ample and which are basepoint free.

- (a) X_Σ is the toric variety of the smooth complete fan Σ in \mathbb{R}^2 with

$$\Sigma(1) = \{\pm e_1, \pm e_2, e_1 + e_2\}.$$

- (b) X_Σ is the blowup $\text{Bl}_p(\mathbb{P}^n)$ of \mathbb{P}^n at a fixed point p of the torus action.
- (c) X_Σ is the toric variety of the fan Σ from Exercise 3.3.10. See Figure 12 from Chapter 3.
- (d) X_Σ is the toric variety of the fan obtained from the fan of Figure 12 from Chapter 3 by combining the two upward pointing cones.

6.1.12. The toric variety $(\mathbb{P}^1)^n$ has ray generators $\pm e_1, \dots, \pm e_n$. Let D_1^\pm, \dots, D_n^\pm denote the corresponding torus-invariant divisors. Consider $D = \sum_{i=1}^n (a_i^+ D_i^+ + a_i^- D_i^-)$.

- (a) Show that D is basepoint free if and only if $a_i^+ + a_i^- \geq 0$ for all i .
- (b) Show that D is ample if and only if $a_i^+ + a_i^- > 0$ for all i .

6.1.13. Let $D = \sum_{\rho} a_{\rho} D_{\rho}$ be an ample divisor on a complete toric variety X_{Σ} . Define

$$\sigma = \text{Cone}((u_{\rho}, -a_{\rho}) \mid \rho \in \Sigma(1)) \subseteq N_{\mathbb{R}} \times \mathbb{R}.$$

- (a) Prove that σ is strongly convex.
- (b) Prove that the boundary of σ is the graph of the support function φ_D .
- (c) Prove that Σ is the set of cones obtained by projecting proper faces of σ onto $M_{\mathbb{R}}$.

6.1.14. Let Σ be the fan from Example 4.2.13. Prove the X_{Σ} is not projective.

6.1.15. Let $P \subseteq M_{\mathbb{R}}$ be a full dimensional lattice polytope. A face $Q \preceq P$ determines a cone σ_Q in the normal fan of P . This gives the orbit closure $V(\sigma_Q) \subseteq X_P$, and $V(\sigma_Q) \simeq X_Q$ by Proposition 3.2.9. This gives an inclusion $i : X_Q \rightarrow X_P$ which is not a toric morphism when $Q \prec P$. Prove that $i^* \mathcal{O}_{X_P}(D_P) \simeq \mathcal{O}_{X_Q}(D_Q)$.

§6.2. The Nef and Mori Cones

In the last section, we saw that there are simple criteria which determine when a Cartier divisor D is basepoint free or ample. We now study the structure of the set of basepoint free divisors and the set of ample divisors inside $\text{Pic}(X_{\Sigma})_{\mathbb{R}} = \text{Pic}(X_{\Sigma}) \otimes_{\mathbb{Z}} \mathbb{R}$.

The main concept of this section is that of *numerical effectivity*. Roughly speaking, the goal is to define a pairing between divisors and curves, such that for a divisor D and curve C on a variety X , the number $D \cdot C$ counts the number of points of $D \cap C$, with appropriate multiplicity.

Example 6.2.1. Suppose $X = \mathbb{P}^2$ with homogeneous coordinates x, y, z , and let $D = \mathbf{V}(y)$ and $C = \mathbf{V}(zy - x^2)$. Then D and C meet at the single point $p = (0, 0, 1)$, where they share a common tangent. If we replace D with the linearly equivalent divisor $E = \mathbf{V}(y - z)$, then clearly E and C meet in two points. This suggests that the point $\{p\} = D \cap C$ should be counted twice, since it is a tangent point. Hence we should have $D \cdot C = 2$. \diamond

Despite this encouraging example, there are several technical hurdles to overcome in order to make this precise in a general setting. Note that in \mathbb{C}^2 , two lines may or may not meet, so to get a reasonable theory, we will work with *complete curves* C on a normal variety X . We also need to restrict to *Cartier divisors* D on X . With these assumptions, the intersection product $D \cdot C$ should possess the following properties:

- $(D + E) \cdot C = D \cdot C + E \cdot C$.
- $D \cdot C = E \cdot C$ when $D \sim E$.
- Let D be a prime divisor on X such that $D \cap C$ is finite. Assume each $p \in D \cap C$ is smooth in C, D, X and that the tangent spaces $T_p(C) \subseteq T_p(X)$ and $T_p(D) \subseteq T_p(X)$ meet transversely. Then $D \cdot C = |D \cap C|$.

Note that these properties give a rigorous proof of the computation $D \cdot C = 2$ from Example 6.2.1.

The Degree of a Line Bundle. The key tool we will use is the notion of the *degree* of a divisor on an irreducible smooth complete curve C . Such a divisor can be written as a finite sum $D = \sum_i a_i p_i$ where $a_i \in \mathbb{Z}$ and $p_i \in C$.

Definition 6.2.2. Let $D = \sum_i a_i p_i$ be a divisor on an irreducible smooth complete curve C . Then the *degree* of D is the integer

$$\deg(D) = \sum_i a_i \in \mathbb{Z}.$$

Note the obvious property $\deg(D + E) = \deg(D) + \deg(E)$. The following key result is proved in [77, Cor. II.6.10].

Theorem 6.2.3. *Every principal divisor on an irreducible smooth complete curve has degree zero.* \square

In other words, $\deg(\operatorname{div}(f)) = 0$ for all nonzero rational functions f on an irreducible smooth complete curve C . Thus

$$\deg(D) = \deg(E) \text{ when } D \sim E \text{ on } C,$$

and the degree map induces a surjective homomorphism

$$\deg : \operatorname{Pic}(C) \longrightarrow \mathbb{Z}.$$

Note that all Weil divisors are Cartier since C is smooth.

In §6.0 we showed that $\operatorname{Pic}(C)$ is the set of isomorphism classes of line bundles on C . Hence we can define the degree $\deg(\mathcal{L})$ of a line bundle \mathcal{L} on C . This leads immediately to the following result.

Proposition 6.2.4. *Let C be an irreducible smooth complete curve. Then a line bundle \mathcal{L} has a *degree* $\deg(\mathcal{L})$ such that $\mathcal{L} \mapsto \deg(\mathcal{L})$ has the following properties:*

- (a) $\deg(\mathcal{L} \otimes \mathcal{L}') = \deg(\mathcal{L}) + \deg(\mathcal{L}')$.
- (b) $\deg(\mathcal{L}) = \deg(\mathcal{L}')$ when $\mathcal{L} \simeq \mathcal{L}'$.
- (c) $\deg(\mathcal{L}) = \deg(D)$ when $\mathcal{L} \simeq \mathcal{O}_C(D)$. \square

The Normalization of a Curve. We defined the normalization of an affine variety in §1.0, and by gluing together the normalizations of affine pieces, one can define the normalization of any variety (see [77, Ex. II.3.8]). In particular, an irreducible curve C has a normalization map

$$\phi : \bar{C} \longrightarrow C,$$

where \bar{C} is a normal variety. Here are the key properties of \bar{C} .

Proposition 6.2.5. *Let \bar{C} be the normalization of an irreducible curve C . Then:*

- (a) \bar{C} is smooth.
- (b) \bar{C} is complete whenever C is complete.

Proof. Since C is a curve, Proposition 4.0.17 implies that C is smooth. Part (b) is covered by [77, Ex. II.5.8]. \square

One can prove that every irreducible smooth complete curve is projective. See [77, Ex. II.5.8].

The Intersection Product. We now have the tools needed to define the intersection product. Let X be a normal variety. Given a Cartier divisor D on X and an irreducible complete curve $C \subseteq X$, we have

- The line bundle $\mathcal{O}_X(D)$ on X .
- The normalization $\phi: \bar{C} \rightarrow C$.

Then $\phi^* \mathcal{O}_X(D)$ is a line bundle on the irreducible smooth complete curve \bar{C} .

Definition 6.2.6. The *intersection product* of D and C is $D \cdot C = \deg(\phi^* \mathcal{O}_X(D))$.

Here are some properties of the intersection product.

Proposition 6.2.7. *Let C be an irreducible complete curve and D, E Cartier divisors on a normal variety X . Then:*

- (a) $(D + E) \cdot C = D \cdot C + E \cdot C$.
- (b) $D \cdot C = E \cdot C$ when $D \sim E$.

Proof. The pullback of line bundles is compatible with tensor product, so that part (a) follows from (6.0.3) and Proposition 6.2.4. Part (b) is an easy consequence of Propositions 6.0.22 and 6.2.4. \square

In Chapter 4, we defined a Weil divisor D to be \mathbb{Q} -Cartier if ℓD is Cartier for some integer $\ell > 0$. Given an irreducible complete curve $C \subseteq X$, let

$$(6.2.1) \quad D \cdot C = \frac{1}{\ell} (\ell D) \cdot C.$$

In Exercise 6.2.1 you will show that this intersection product is well-defined and satisfies Proposition 6.2.7.

Intersection Products on Toric Varieties. In the toric case, $D \cdot C$ is easy to compute when D and C are torus-invariant in X_Σ . In order for C to be torus-invariant and complete, we must have $C = V(\tau) = \overline{\mathcal{O}(\tau)}$, where $\tau = \sigma \cap \sigma' \in \Sigma(n-1)$ is the wall separating cones $\sigma, \sigma' \in \Sigma(n)$, $n = \dim X_\Sigma$. We do not assume Σ is complete.

In this situation, we have the sublattice $N_\tau = \text{Span}(\tau) \cap N \subseteq N$ and the quotient $N(\tau) = N/N_\tau$. Let $\bar{\sigma}$ and $\bar{\sigma}'$ be the images of σ and σ' in $N(\tau)_\mathbb{R}$. Since τ is a wall, $N(\tau) \simeq \mathbb{Z}$ and $\bar{\sigma}, \bar{\sigma}'$ are rays that correspond to the rays in the usual fan for \mathbb{P}^1 . In particular, $V(\tau) \simeq \mathbb{P}^1$ is smooth, so no normalization is needed when computing the intersection product.

Proposition 6.2.8. *Let $C = V(\tau)$ be the complete torus-invariant curve in X_Σ coming from the wall $\tau = \sigma \cap \sigma'$. Let D be a Cartier divisor with Cartier data $m_\sigma, m_{\sigma'} \in M$ corresponding to $\sigma, \sigma' \in \Sigma(n)$. Also pick $u \in \sigma' \cap N$ that maps to the minimal generator of $\bar{\sigma}' \subseteq N(\tau)_\mathbb{R}$. Then*

$$D \cdot C = \langle m_\sigma - m_{\sigma'}, u \rangle \in \mathbb{Z}.$$

Proof. Since $V(\tau) \subseteq U_\sigma \cup U_{\sigma'}$, we can assume $X_\Sigma = U_\sigma \cup U_{\sigma'}$ and Σ is the fan consisting of σ, σ' and their faces. We also have

$$D|_{U_\sigma} = \operatorname{div}(\chi^{-m_\sigma})|_{U_\sigma}, \quad D|_{U_{\sigma'}} = \operatorname{div}(\chi^{-m_{\sigma'}})|_{U_{\sigma'}}.$$

The proof of Proposition 6.1.20 shows that the line bundle $\mathcal{O}_{X_\Sigma}(D)$ is determined by the transition function $g_{\sigma'\sigma} = \chi^{m_\sigma - m_{\sigma'}}$. Thus

$$D \cdot C = \deg(i^* \mathcal{O}_{X_\Sigma}(D)),$$

where $i: V(\tau) \hookrightarrow X_\Sigma$ is the inclusion map. The pullback bundle is determined by the restriction of $g_{\sigma'\sigma}$ to

$$V(\tau) \cap U_\sigma \cap U_{\sigma'} = V(\tau) \cap U_\tau = O(\tau),$$

where $O(\tau)$ is the T_N -orbit corresponding to τ . This is also the torus of the toric variety $V(\tau) = \overline{O(\tau)}$. In Lemma 3.2.5, we showed that $\tau^\perp \cap M$ is the dual of $N(\tau)$ and that

$$O(\tau) \simeq \operatorname{Hom}_\mathbb{Z}(M \cap \tau^\perp, \mathbb{C}^*) \simeq T_{N(\tau)}.$$

Now comes the key observation: since the linear functions given by $m_\sigma, m_{\sigma'}$ agree on τ , we have $m_\sigma - m_{\sigma'} \in \tau^\perp \cap M$. Thus $i^* \mathcal{O}_{X_\Sigma}(D)$ is the line bundle on $V(\tau)$ whose transition function is $g_{\sigma'\sigma} = \chi^{m_\sigma - m_{\sigma'}}$ for $m_\sigma - m_{\sigma'} \in \tau^\perp \cap M$.

It follows that $i^* \mathcal{O}_{X_\Sigma}(D) \simeq \mathcal{O}_{V(\tau)}(\bar{D})$, where \bar{D} is the divisor on $V(\tau)$ given by the Cartier data

$$m_{\bar{\sigma}} = 0, \quad m_{\bar{\sigma}'} = m_{\sigma'} - m_\sigma.$$

Let $p_\sigma, p_{\sigma'}$ be the torus fixed points corresponding to σ, σ' . Since $u \in \sigma' \cap N$ maps to the minimal generator $\bar{u} \in \bar{\sigma}' \cap N(\tau)$, we have

$$\bar{D} = \langle -m_{\bar{\sigma}}, -\bar{u} \rangle p_\sigma + \langle -m_{\bar{\sigma}'}, \bar{u} \rangle p_{\sigma'} = \langle m_\sigma - m_{\sigma'}, u \rangle p_{\sigma'},$$

where the second equality follows from $m_{\bar{\sigma}'} = m_{\sigma'} - m_\sigma \in \tau^\perp \cap M$. Hence

$$D \cdot C = \deg(i^* \mathcal{O}_{X_\Sigma}(D)) = \deg(\bar{D}) = \langle m_\sigma - m_{\sigma'}, u \rangle. \quad \square$$

Example 6.2.9. Consider the toric surface whose fan Σ in \mathbb{R}^2 has ray generators

$$u_1 = e_1, \quad u_2 = e_2, \quad u_0 = 2e_1 + 3e_2$$

and maximal cones

$$\sigma = \operatorname{Cone}(u_1, u_0), \quad \sigma' = \operatorname{Cone}(u_2, u_0).$$

The support of Σ is the first quadrant and $\tau = \sigma \cap \sigma' = \operatorname{Cone}(u_0)$ gives the complete torus-invariant curve $C = V(\tau) \subseteq X_\Sigma$.

If D_1, D_2, D_0 are the divisors corresponding to u_1, u_2, u_0 , then

$$D = aD_1 + bD_2 + cD_0 \text{ is Cartier} \iff 2a + 3b \equiv c \pmod{6}.$$

When this condition is satisfied, we have

$$m_\sigma = -ae_1 + \frac{2a-c}{3}e_2, \quad m_{\sigma'} = \frac{3b-c}{2}e_1 - be_2.$$

Also, $u = e_1 + 2e_2 \in \sigma'$ maps to the minimal generator of $\bar{\sigma}'$ since u, u_0 form a basis of \mathbb{Z}^2 . (You will check these assertions in Exercise 6.2.2.) Thus

$$D \cdot C = \langle m_\sigma - m_{\sigma'}, u \rangle = \frac{2a + 3b - c}{6}$$

by Proposition 6.2.8. Since D is \mathbb{Q} -Cartier (Σ is simplicial), (6.2.1) shows that the formula for $D \cdot C$ holds for arbitrary integers a, b, c . In particular,

$$D_1 \cdot C = \frac{1}{3}, \quad D_2 \cdot C = \frac{1}{2}, \quad D_0 \cdot C = -\frac{1}{6}.$$

In the next section we will see that these intersection products follow directly from the relation $-u_0 + 2u_1 + 3u_2 = 0$ and the fact that $\mathbb{Z}u_0 = \text{Span}(\tau) \cap \mathbb{Z}^2$. \diamond

Nef Divisors. We now define an important class of Cartier divisors.

Definition 6.2.10. Let X be a normal variety. Then a Cartier divisor D on X is **nef** (short for *numerically effective*) if

$$D \cdot C \geq 0$$

for every irreducible complete curve $C \subseteq X$.

A divisor linearly equivalent to a nef divisor is nef. Here is another result.

Proposition 6.2.11. *Every basepoint free divisor is nef.*

Proof. The pullback of a line bundle generated by global sections is generated by global sections (Exercise 6.0.10). Thus, given $\phi : \bar{C} \rightarrow C$ and D basepoint free, the line bundle $\mathcal{L} = \phi^*(\mathcal{O}_X(D))$ is generated by global sections. This allows us to write $\mathcal{L} = \mathcal{O}_{\bar{C}}(D')$ for a basepoint free divisor D' on \bar{C} . A nonzero global section of $\mathcal{O}_{\bar{C}}(D')$ gives an effective divisor E' linearly equivalent to D' . Then

$$D \cdot C = \deg(\phi^*(\mathcal{O}_X(D))) = \deg(\mathcal{O}_{\bar{C}}(D')) = \deg(D') = \deg(E') \geq 0,$$

where the last inequality follows since E' is effective. \square

In the toric case, nef divisors are especially easy to understand.

Theorem 6.2.12. *Let D be a Cartier divisor on a complete toric variety X_Σ . The following are equivalent:*

- (a) D is basepoint free, i.e., $\mathcal{O}_X(D)$ is generated by global sections.
- (b) D is nef.
- (c) $D \cdot C \geq 0$ for all torus-invariant irreducible curves $C \subseteq X$.

Proof. The first item implies the second by Proposition 6.2.11, and the second item implies the third by the definition of nef. So suppose that $D \cdot C \geq 0$ for all torus-invariant irreducible curves C . We can replace D with a linearly equivalent torus-invariant divisor. Then, by Theorem 6.1.10, it suffices to show that ϕ_D is convex.

Take a wall $\tau = \sigma \cap \sigma'$ of Σ and set $C = V(\tau)$. If we pick $u \in \sigma' \cap N$ as in Proposition 6.2.8, then

$$\langle m_\sigma - m_{\sigma'}, u \rangle = D \cdot C \geq 0,$$

so that

$$\langle m_\sigma, u \rangle \geq \langle m_{\sigma'}, u \rangle = \varphi_D(u).$$

Note that $u \notin \sigma$ since the image of u is nonzero in $N(\tau) = N/(\text{Span}(\tau) \cap N)$. Then Lemma 6.1.8 implies that φ_D is convex. \square

A variant of the above proof leads to the following ampleness criterion, which you will prove in Exercise 6.2.3.

Theorem 6.2.13 (Toric Kleiman Criterion). *Let D be a Cartier divisor on a complete toric variety X_Σ . Then D is ample if and only if $D \cdot C > 0$ for all torus-invariant irreducible curves $C \subseteq X_\Sigma$.* \square

Note that one direction of the proof follows from the general fact that on any complete normal variety, an ample divisor D satisfies $D \cdot C > 0$ for all irreducible curves $C \subseteq X$ (Exercise 6.2.4).

Theorems 6.2.12 and 6.2.13 were well-known in the smooth case and proved more recently (and independently) in [112, 120, 130] in the complete case.

Numerical Equivalence of Divisors. The intersection product leads to an important equivalence relation on Cartier divisors.

Definition 6.2.14. Let X be a normal variety.

- (a) A Cartier divisor D on X is **numerically equivalent to zero** if $D \cdot C = 0$ for all irreducible complete curves $C \subseteq X$.
- (b) Cartier divisors D and E are **numerically equivalent**, written $D \equiv E$, if $D - E$ is numerically equivalent to zero.

What does this say in the toric case?

Proposition 6.2.15. *Let D be a Cartier divisor on a complete toric variety X_Σ . Then $D \sim 0$ if and only if $D \equiv 0$.*

Proof. Clearly if D is principal then D is numerically equivalent to zero. For the converse, assume $D \equiv 0$ and let $\tau = \sigma \cap \sigma'$ be a wall of Σ . If we pick $u \in \sigma'$ as in Proposition 6.2.8, then

$$0 = D \cdot C = \langle m_\sigma - m_{\sigma'}, u \rangle$$

for $C = V(\tau)$. This forces $m_\sigma = m_{\sigma'}$ since $m_\sigma - m_{\sigma'} \in \tau^\perp$ and $u \notin \sigma$. From here, one sees that $m_\sigma = m_{\sigma'}$ for all $\sigma, \sigma' \in \Sigma(n)$, and it follows that D is principal. \square

Numerical Equivalence of Curves. We also get an interesting equivalence relation on curves. Let $Z_1(X)$ be the free abelian group generated by irreducible complete curves $C \subseteq X$. An element of $Z_1(X)$ is called a *proper 1-cycle*.

Definition 6.2.16. Let X be a normal variety.

- (a) A proper 1-cycle C on X is **numerically equivalent to zero** if $D \cdot C = 0$ for all Cartier divisors D on X .
- (b) Proper 1-cycles C and C' are **numerically equivalent**, written $C \equiv C'$, if $C - C'$ is numerically equivalent to zero.

The intersection product $(D, C) \mapsto D \cdot C$ extends naturally to a pairing

$$\text{CDiv}(X) \times Z_1(X) \longrightarrow \mathbb{Z}.$$

between Cartier divisors and 1-cycles. In order to get a nondegenerate pairing, we work over \mathbb{R} and mod out by numerical equivalence.

Definition 6.2.17. For a normal variety X , define

$$N^1(X) = (\text{CDiv}(X)/\equiv) \otimes_{\mathbb{Z}} \mathbb{R} \quad \text{and} \quad N_1(X) = (Z_1(X)/\equiv) \otimes_{\mathbb{Z}} \mathbb{R}.$$

It follows easily that we get a well-defined nondegenerate bilinear pairing

$$N^1(X) \times N_1(X) \longrightarrow \mathbb{R}.$$

A deeper fact is that $N^1(X)$ and $N_1(X)$ have finite dimension over \mathbb{R} . Thus $N^1(X)$ and $N_1(X)$ are dual vector spaces via intersection product.

The Nef and Mori Cones. The vector spaces $N^1(X)$ and $N_1(X)$ contain some interesting cones.

Definition 6.2.18. Let X be a normal variety.

- (a) $\text{Nef}(X)$ is the cone in $N^1(X)$ generated by classes of nef Cartier divisors. We call $\text{Nef}(X)$ the **nef cone**.
- (b) $NE(X)$ is the cone in $N_1(X)$ generated by classes of irreducible complete curves.
- (c) $\overline{NE}(X)$ is the closure of $NE(X)$ in $N_1(X)$. We call $\overline{NE}(X)$ the **Mori cone**.

Here are some easy observations about the nef and Mori cones.

Lemma 6.2.19.

- (a) $\text{Nef}(X)$ and $\overline{NE}(X)$ are closed convex cones and are dual to each other, i.e.,

$$\text{Nef}(X) = \overline{NE}(X)^\vee \quad \text{and} \quad \overline{NE}(X) = \text{Nef}(X)^\vee.$$

- (b) $NE(X)$ has maximal dimension in $N_1(X)$.
- (c) $\text{Nef}(X)$ is strongly convex in $N^1(X)$.

Proof. It is obvious that $Nef(X)$, $NE(X)$ and $\overline{NE}(X)$ are convex cones, and $Nef(X)$ is closed since it is defined by inequalities of the form $D \cdot C \geq 0$. In fact,

$$Nef(X) = NE(X)^\vee$$

by the definition of nef. Then $Nef(X) = \overline{NE}(X)^\vee$ follows easily. In general, $NE(X)$ need not be closed. However, since the closure of a convex cone is its double dual, we have

$$\overline{NE}(X) = NE(X)^{\vee\vee} = Nef(X)^\vee.$$

Note that $NE(X)$ has maximal dimension since $N_1(X)$ is spanned by the classes of irreducible complete curves. Hence the same is true for its closure $\overline{NE}(X)$. Then $Nef(X)$ is strongly convex since its the dual has maximal dimension. \square

The toric case is especially nice. If we set $\text{Pic}(X_\Sigma)_\mathbb{R} = \text{Pic}(X_\Sigma) \otimes_{\mathbb{Z}} \mathbb{R}$, then

$$\text{Pic}(X_\Sigma)_\mathbb{R} = N^1(X_\Sigma)$$

since numerical and linear equivalence coincide by Proposition 6.2.15. Thus, in the toric setting, we will write $\text{Pic}(X_\Sigma)_\mathbb{R}$ instead of $N^1(X_\Sigma)$. When Σ is complete, the inclusion

$$\text{Pic}(X_\Sigma) \subseteq \text{Pic}(X_\Sigma)_\mathbb{R}$$

makes $\text{Pic}(X_\Sigma)$ a lattice in the vector space $\text{Pic}(X_\Sigma)_\mathbb{R}$.

Theorem 6.2.20. *Let X_Σ be a complete toric variety.*

- (a) $Nef(X_\Sigma)$ is a rational polyhedral cone in $\text{Pic}(X_\Sigma)_\mathbb{R}$.
- (b) $\overline{NE}(X_\Sigma) = NE(X_\Sigma)$ is a rational polyhedral cone in $N_1(X_\Sigma)$. Furthermore,

$$\overline{NE}(X_\Sigma) = \sum_{\tau \in \Sigma(n-1)} \mathbb{R}_{\geq 0}[V(\tau)],$$

where $[V(\tau)] \in N_1(X_\Sigma)$ is the class of $V(\tau)$.

Proof. Part (a) is an immediate consequence of part (b). For part (b), let $\Gamma = \sum_{\tau \in \Sigma(n-1)} \mathbb{R}_{\geq 0}[V(\tau)]$ and note that Γ is a rational polyhedral cone contained in $NE(X_\Sigma)$. Furthermore, Theorem 6.2.12 easily implies

$$Nef(X_\Sigma) = \Gamma^\vee.$$

Then

$$\overline{NE}(X_\Sigma) = Nef(X_\Sigma)^\vee = \Gamma^{\vee\vee} = \Gamma \subseteq NE(X_\Sigma) \subseteq \overline{NE}(X_\Sigma),$$

where the third equality follows since Γ is polyhedral. \square

The formula from part (b) of Theorem 6.2.20

$$\overline{NE}(X_\Sigma) = \sum_{\tau \in \Sigma(n-1)} \mathbb{R}_{\geq 0}[V(\tau)],$$

is called the *Toric Cone Theorem*. Although the Mori cone equals $NE(X_\Sigma)$ in this case, we will continue to write $\overline{NE}(X_\Sigma)$ for consistency with the literature. Since

every irreducible curve $C \subseteq X_\Sigma$ gives a class in $\overline{NE}(X_\Sigma)$, we get the following corollary of the Toric Cone Theorem.

Corollary 6.2.21. *An irreducible curve in a complete toric variety X_Σ is numerically equivalent to a non-negative combination of torus-invariant curves.* \square

When X_Σ is projective we can say more about the nef and Mori cones.

Theorem 6.2.22. *Let X_Σ be a projective toric variety. Then:*

- (a) *Nef(X_Σ) and $\overline{NE}(X_\Sigma)$ are dual strongly convex rational polyhedral cones of maximal dimension.*
- (b) *A Cartier divisor D is ample if and only if its class in $\text{Pic}(X_\Sigma)_\mathbb{R}$ lies in the interior of Nef(X_Σ).*

Proof. By hypothesis, X_Σ has an ample divisor D . Then $D \cdot C > 0$ for every irreducible curve in X_Σ . This easily implies that the class of D lies in the interior of $\text{Nef}(X_\Sigma)$. Thus $\text{Nef}(X_\Sigma)$ has maximal dimension and hence its dual $\overline{NE}(X_\Sigma)$ is strongly convex. When combined with Lemma 6.2.19, part (a) follows easily.

The strict inequality $D \cdot C > 0$ also shows that every irreducible curve gives a nonzero class in $N_1(X_\Sigma)$. Now suppose that the class of D is in the interior of the nef cone. Then $[D]$ defines a supporting hyperplane of the origin of the dual cone $\overline{NE}(X_\Sigma)$. Since $0 \neq [C] \in \overline{NE}(X_\Sigma)$ for every irreducible curve $C \subseteq X_\Sigma$, we have $D \cdot C > 0$ for all such C . Hence D is ample by Theorem 6.2.13. \square

It follows that $\overline{NE}(X_\Sigma)$ is strongly convex in the projective case. The rays of $\overline{NE}(X_\Sigma)$ are called *extremal rays*, which by the Toric Cone Theorem are of the form $\mathbb{R}_{\geq 0}[V(\tau)]$. The corresponding walls τ are called *extremal walls*.

Here is an example of the cones $\text{Nef}(X_\Sigma)$ and $\overline{NE}(X_\Sigma)$.

Example 6.2.23. For the Hirzebruch surface cH_r , we showed in Example 6.1.17 that $\text{Pic}(\mathcal{H}_r) = \{a[D_3] + b[D_4] \mid a, b \in \mathbb{Z}\}$. Figure 11 shows $\text{Nef}(\mathcal{H}_r)$ and $\overline{NE}(\mathcal{H}_r)$.

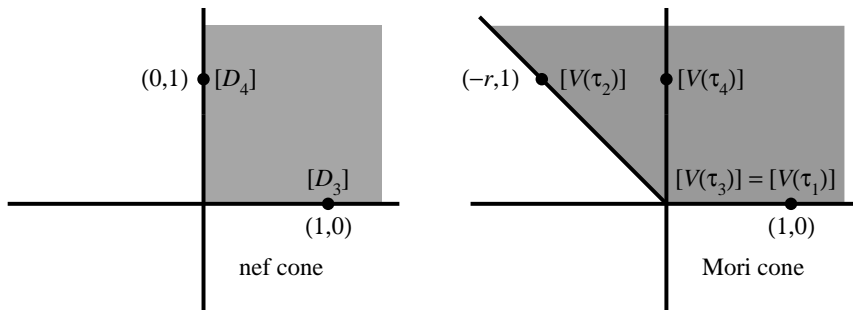

Figure 11. The nef and Mori cones of \mathcal{H}_r

Here, $\tau_i = \text{Cone}(u_i)$, so that $D_i = V(\tau_i)$. Using both notations helps distinguish between $\text{Nef}(\mathcal{H}_r)$ (built from divisors) and $\overline{\text{NE}}(\mathcal{H}_r)$ (built from curves).

The description of the nef cone follows from the characterization of ample divisors on \mathcal{H}_r given in Example 6.1.17. The Mori cone is generated by the class of the $V(\tau_i)$ by the Toric Cone Theorem. Using the the basis given by $D_3 = V(\tau_3)$, $D_4 = V(\tau_4)$ and the linear equivalences

$$D_1 \sim D_3, \quad D_2 \sim -rD_3 + D_4$$

from Example 6.1.17, we get the picture of $\overline{\text{NE}}(\mathcal{H}_r)$ shown in Figure 11. It follows that $[V(\tau_2)]$ and $[V(\tau_3)] = [V(\tau_1)]$ generate extremal rays, while $[V(\tau_4)]$ does not. Thus τ_1, τ_2, τ_3 are extremal walls.

The explicit duality between the cones $\text{Nef}(X_\Sigma)$ and $\overline{\text{NE}}(X_\Sigma)$ in Figure 11 will be described in the next section.

Theorem 6.2.22 tells us that ample divisors correspond to lattice points in the interior of $\text{Nef}(\mathcal{H}_r)$. Thus lattice points on the boundary correspond to divisors that are basepoint free but not ample. We can see this vividly by looking at the polytopes P_D associated to divisors D whose classes lie in $\text{Nef}(\mathcal{H}_r)$.

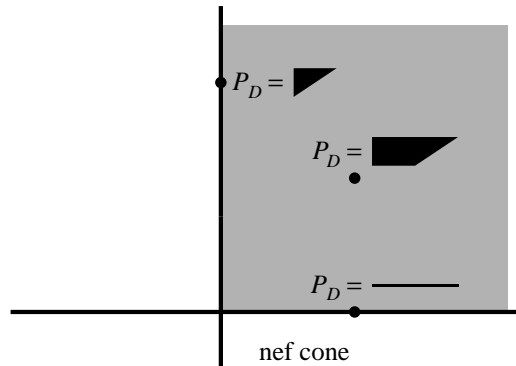

Figure 12. Polytopes P_D associated to divisors D in nef cone of \mathcal{H}_r

Figure 12 shows that when D is in the interior of the nef cone, P_D is a polygon whose normal fan is the fan of \mathcal{H}_r . On the boundary of the nef cone, however, things are different— P_D is a triangle on the vertical ray and a line segment on the horizontal ray. You will verify these claims in Exercise 6.2.5. \diamond

When X_Σ is not a projective variety, the ampleness criterion given in part (b) of Theorem 6.2.22 can fail. Here is an example due to Fujino [55].

Example 6.2.24. Consider the complete fan in \mathbb{R}^3 with six minimal generators

$$\begin{aligned} u_1 &= (1, 0, 1), & u_2 &= (0, 1, 1), & u_3 &= (-1, -1, 1) \\ u_4 &= (1, 0, -1), & u_5 &= (0, 1, -1), & u_6 &= (-1, -1, -1) \end{aligned}$$

and six maximal cones

$$\begin{aligned} &\text{Cone}(u_1, u_2, u_3), \text{Cone}(u_1, u_2, u_4), \text{Cone}(u_2, u_4, u_5) \\ &\text{Cone}(u_1, u_3, u_4, u_6), \text{Cone}(u_2, u_3, u_5, u_6), \text{Cone}(u_4, u_5, u_6). \end{aligned}$$

You will draw a picture of this fan in Exercise 6.2.6 and show that the resulting complete toric variety satisfies

$$\text{Pic}(X_\Sigma) \simeq \{a(D_1 + D_4) \mid a \in 3\mathbb{Z}\} \simeq \mathbb{Z}.$$

The maximal cones $\sigma = \text{Cone}(u_1, u_2, u_4)$ and $\sigma' = \text{Cone}(u_2, u_4, u_5)$ meet along the wall

$$\tau = \sigma \cap \sigma' = \text{Cone}(u_2, u_4).$$

However, any Cartier divisor $D = \sum_{i=1}^6 a_i D_i$ satisfies $m_\sigma = m_{\sigma'}$ (Exercise 6.2.6), so that the irreducible complete curve $C = V(\tau)$ satisfies

$$D \cdot C = 0$$

by Proposition 6.2.8. This holds for all Cartier divisors on X_Σ , so $C \equiv 0$. Then X_Σ has no ample divisors by the Toric Kleiman Criterion, so that X_Σ is nonprojective.

The nef cone of X_Σ is the half-line

$$\text{Nef}(X_\Sigma) = \{a[D_1 + D_4] \mid a \geq 0\}$$

(Exercise 6.2.6). It follows that the Cartier divisor $D = 3(D_1 + D_4)$ gives a class in the interior of the nef cone, yet D is not ample. Hence part (b) of Theorem 6.2.22 is false for X_Σ . The failure is due to the existence of irreducible curves in X_Σ that are numerically equivalent to zero. This shows that numerical equivalence of curves can be badly behaved in the nonprojective case. \diamond

Exercises for §6.2.

6.2.1. Let X be a normal variety. Prove that (6.2.1) gives a well-defined pairing between \mathbb{Q} -Cartier divisors and irreducible complete curves. Also show that this pairing satisfies Proposition 6.2.7.

6.2.2. Derive the formulas for m_σ and $m_{\sigma'}$ given in Example 6.2.9.

6.2.3. Prove Theorem 6.2.13.

6.2.4. Prove that on a complete normal variety, an ample divisor D satisfies $D \cdot C > 0$ for all irreducible curves $C \subseteq X$.

6.2.5. Verify the claims made in Example 6.2.5. Hint: See Examples 6.1.3 and 6.1.24.

6.2.6. Consider the fan Σ from Example 6.2.24.

- (a) Draw a picture of this fan in \mathbb{R}^3 .
- (b) Prove that $\text{Pic}(X_\Sigma) \simeq \{a(D_1 + D_4) \mid a \in 3\mathbb{Z}\}$.
- (c) Prove that $3(D_1 + D_4)$ is nef.

§6.3. The Simplicial Case

Here we assume that Σ is a simplicial fan in $N_{\mathbb{R}} \simeq \mathbb{R}^n$. Then Proposition 4.2.7 implies that every Weil divisor is \mathbb{Q} -Cartier. Since we will be working in $\text{Pic}(X_{\Sigma})_{\mathbb{R}}$, it follows that we can drop the adjective ‘‘Cartier’’ when discussing divisors.

Relations Among Minimal Generators. We begin our discussion of the simplicial case with another way to think of elements of $N_1(X_{\Sigma})$. Recall from Theorem 4.1.3 that we have an exact sequence

$$(6.3.1) \quad M \xrightarrow{\alpha} \mathbb{Z}^{\Sigma(1)} \xrightarrow{\beta} \text{Cl}(X_{\Sigma}) \longrightarrow 0$$

where $\alpha(m) = (\langle m, u_{\rho} \rangle)_{\rho \in \Sigma(1)}$ and β sends the standard basis element $e_{\rho} \in \mathbb{Z}^{\Sigma(1)}$ to $[D_{\rho}] \in \text{Cl}(X_{\Sigma})$.

Proposition 6.3.1. *Let Σ be a simplicial fan in $N_{\mathbb{R}} \simeq \mathbb{R}^n$. Then there are dual exact sequences*

$$M_{\mathbb{R}} \xrightarrow{\alpha} \mathbb{R}^{\Sigma(1)} \xrightarrow{\beta} \text{Pic}(X_{\Sigma})_{\mathbb{R}} \longrightarrow 0$$

and

$$0 \longrightarrow N_1(X_{\Sigma}) \xrightarrow{\beta^*} \mathbb{R}^{\Sigma(1)} \xrightarrow{\alpha^*} N_{\mathbb{R}}$$

where

$$\begin{aligned} \alpha^*(e_{\rho}) &= u_{\rho}, & e_{\rho} & \text{a standard basis vector of } \mathbb{R}^{\Sigma(1)} \\ \beta^*([C]) &= (D_{\rho} \cdot C)_{\rho \in \Sigma(1)}, & C & \subseteq X_{\Sigma} \text{ an irreducible complete curve.} \end{aligned}$$

In particular, we may interpret $N_1(X_{\Sigma})$ as the space of linear relations among the minimal generators of Σ .

Proof. Since Σ is simplicial, all Weil divisors are \mathbb{Q} -Cartier. Hence

$$\text{Pic}(X_{\Sigma})_{\mathbb{R}} = \text{Pic}(X_{\Sigma}) \otimes_{\mathbb{Z}} \mathbb{R} = \text{Cl}(X_{\Sigma}) \otimes_{\mathbb{Z}} \mathbb{R}.$$

Tensoring with \mathbb{R} preserves exactness, so exactness of the first sequence follows from (6.3.1).

The dual of an exact sequence of finite-dimensional vector spaces is still exact. Then the perfect pairings

$$\begin{aligned} M_{\mathbb{R}} \times N_{\mathbb{R}} &\rightarrow \mathbb{R} : (m, u) \mapsto \langle m, u \rangle \\ \text{Pic}(X_{\Sigma})_{\mathbb{R}} \times N_1(X_{\Sigma}) &\rightarrow \mathbb{R} : ([D], [C]) \mapsto D \cdot C \end{aligned}$$

easily imply that for $m \in M_{\mathbb{R}}$ and $[C] \in N_1(X_{\Sigma})$, we have

$$\alpha(m) = (\langle m, u_{\rho} \rangle)_{\rho \in \Sigma(1)} \implies \alpha^*(e_{\rho}) = u_{\rho}$$

and

$$\beta(e_{\rho}) = [D_{\rho}] \implies \beta^*([C]) = (D_{\rho} \cdot C)_{\rho \in \Sigma(1)}. \quad \square$$

The map $\beta^* : N_1(X_\Sigma) \rightarrow \mathbb{R}^{\Sigma(1)}$ in Proposition 6.3.1 implies that an irreducible complete curve $C \subseteq X_\Sigma$ gives the relation

$$(6.3.2) \quad \sum_\rho (D_\rho \cdot C) u_\rho = 0 \text{ in } N_{\mathbb{R}}.$$

This can be derived directly as follows. First observe that $m \in M$ gives

$$\sum_\rho \langle m, u_\rho \rangle D_\rho = \text{div}(\chi^m) \sim 0.$$

Taking the intersection product with C , we see that

$$\sum_\rho \langle m, u_\rho \rangle (D_\rho \cdot C) = 0$$

holds for all $m \in M_{\mathbb{R}}$. Writing this as $\langle m, \sum_\rho (D_\rho \cdot C) u_\rho \rangle = 0$, we obtain

$$\sum_\rho (D_\rho \cdot C) u_\rho = 0 \text{ in } N_{\mathbb{R}}.$$

Intersection Products. Our next task is to compute $D_\rho \cdot C$ when C is a torus-invariant complete curve in X_Σ . This means $C = V(\tau)$, where $\tau \in \Sigma(n-1)$ is a wall, meaning that τ is the intersection of two cones in $\Sigma(n)$. Since we are not assuming that Σ is complete, not every element of $\Sigma(n-1)$ need be a wall.

We begin with a case where $D_\rho \cdot V(\tau)$ is easy to compute. Fix a wall

$$\tau = \sigma \cap \sigma'.$$

Since Σ is simplicial, we can label the minimal generators of σ so that

$$\begin{aligned} \sigma &= \text{Cone}(u_{\rho_1}, u_{\rho_2}, \dots, u_{\rho_n}) \\ \tau &= \text{Cone}(u_{\rho_2}, \dots, u_{\rho_n}). \end{aligned}$$

Thus τ is the facet of σ “opposite” to ρ_1 . We will compute the intersection product $D_{\rho_1} \cdot V(\tau)$ in terms of the *multiplicity* (also called the *index*) of a simplicial cone. This is defined as follows. If γ is a simplicial cone with minimal generators u_1, \dots, u_k , then $\text{mult}(\gamma)$ is the index of the sublattice

$$\mathbb{Z}u_1 + \dots + \mathbb{Z}u_k \subseteq N_\gamma = \text{Span}(\gamma) \cap N = (\mathbb{R}u_1 + \dots + \mathbb{R}u_k) \cap N.$$

Lemma 6.3.2. *If τ , σ and ρ_1 are as above, then*

$$D_{\rho_1} \cdot V(\tau) = \frac{\text{mult}(\tau)}{\text{mult}(\sigma)}.$$

Proof. Since $\{u_{\rho_1}, \dots, u_{\rho_n}\}$ is a basis of $N_{\mathbb{Q}}$, we can find $m \in M_{\mathbb{Q}}$ such that

$$\langle m, u_{\rho_i} \rangle = \begin{cases} -1 & i = 1 \\ 0 & i = 2, \dots, n. \end{cases}$$

Pick a positive integer ℓ such that $\ell m \in M$. On $U_\sigma \cup U_{\sigma'}$, ℓD_{ρ_1} is the Cartier divisor determined by $m_\sigma = \ell m$ and $m_{\sigma'} = 0$. By (6.2.1) and Proposition 6.2.8,

$$D_{\rho_1} \cdot V(\tau) = \frac{1}{\ell} (\ell D_{\rho_1}) \cdot V(\tau) = \frac{1}{\ell} \langle \ell m, u \rangle = \langle m, u \rangle,$$

where $u \in \sigma'$ maps to a generator of $\bar{\sigma}' \cap N(\tau)$. Recall that $N(\tau) = N/N_\tau$.

When we combine u with a basis of N_τ , we get a basis of N . Thus there is a positive integer β such that $\rho_1 = -\beta u + v$, $v \in N_\tau$. The minus sign is because u and ρ_1 lie on opposite sides of τ . By considering the sublattices

$$\mathbb{Z}u_{\rho_1} + \mathbb{Z}u_{\rho_2} + \cdots + \mathbb{Z}u_{\rho_n} \subseteq \mathbb{Z}u_{\rho_1} + N_\tau \subseteq \mathbb{Z}u + N_\tau = N,$$

one sees that $\beta = \text{mult}(\sigma)/\text{mult}(\tau)$. Thus

$$u = -\frac{1}{\beta}(u_{\rho_1} - v) = -\frac{\text{mult}(\tau)}{\text{mult}(\sigma)}(u_{\rho_1} - v).$$

Since $m \in \tau^\perp$, it follows that

$$D_{\rho_1} \cdot V(\tau) = \langle m, u \rangle = -\frac{\text{mult}(\tau)}{\text{mult}(\sigma)} \langle m, u_{\rho_1} \rangle = \frac{\text{mult}(\tau)}{\text{mult}(\sigma)}. \quad \square$$

Corollary 6.3.3. *Let Σ be a smooth fan in $N_\mathbb{R} \simeq \mathbb{R}^n$ and $\tau \in \Sigma(n-1)$ be a wall. If $\rho \in \Sigma(1)$ and τ generate a cone of $\Sigma(n)$, then*

$$D_\rho \cdot V(\tau) = 1 \quad \square$$

Given a wall $\tau \in \Sigma(n-1)$, our next task is to compute $D_\rho \cdot V(\tau)$ for the other rays $\rho \in \Sigma(1)$. Let $\tau = \sigma \cap \sigma'$ and write

$$(6.3.3) \quad \begin{aligned} \sigma &= \text{Cone}(u_{\rho_1}, \dots, u_{\rho_n}) \\ \sigma' &= \text{Cone}(u_{\rho_2}, \dots, u_{\rho_{n+1}}) \\ \tau &= \text{Cone}(u_{\rho_2}, \dots, u_{\rho_n}). \end{aligned}$$

This situation is pictured in Figure 13.

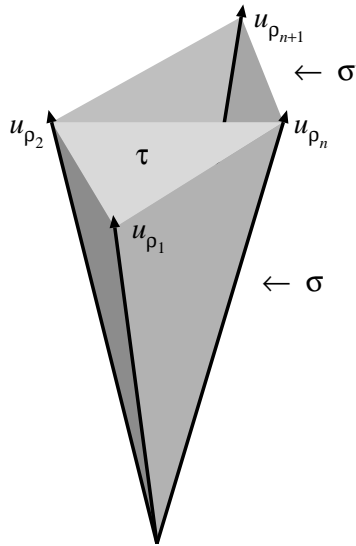

Figure 13. $\tau = \sigma \cap \sigma'$

Applying Lemma 6.3.2 to σ and σ' , we obtain

$$(6.3.4) \quad D_{\rho_1} \cdot V(\tau) = \frac{\text{mult}(\tau)}{\text{mult}(\sigma)}, \quad D_{\rho_{n+1}} \cdot V(\tau) = \frac{\text{mult}(\tau)}{\text{mult}(\sigma')}.$$

To compute $D_\rho \cdot V(\tau)$ when $\rho \neq \rho_1, \rho_{n+1}$, note that the $n+1$ minimal generators $u_{\rho_1}, \dots, u_{\rho_{n+1}}$ are linearly dependent. Hence they satisfy a linear relation, which we write as

$$(6.3.5) \quad \alpha u_{\rho_1} + \sum_{i=2}^n b_i u_{\rho_i} + \beta u_{\rho_{n+1}} = 0.$$

We may assume $\alpha, \beta > 0$ since u_{ρ_1} and $u_{\rho_{n+1}}$ lie on opposite sides of the wall τ . Then (6.3.5) is unique up to multiplication by a positive constant since $u_{\rho_1}, \dots, u_{\rho_n}$ are linearly independent. We call (6.3.5) a *wall relation*.

On the other hand, setting $C = V(\tau)$ in (6.3.2) gives the linear relation

$$(6.3.6) \quad \sum_{\rho} (D_\rho \cdot V(\tau)) u_\rho = 0$$

As we now prove, the two relations are the same up to a positive constant.

Lemma 6.3.4. *The relations given by (6.3.5) and (6.3.6) are equal after multiplication by a positive constant. In particular,*

$$D_\rho \cdot V(\tau) = 0, \quad \text{for all } \rho \notin \{\rho_1, \dots, \rho_{n+1}\}$$

and

$$D_{\rho_i} \cdot V(\tau) = \frac{b_i \text{mult}(\tau)}{\alpha \text{mult}(\sigma)} = \frac{b_i \text{mult}(\tau)}{\beta \text{mult}(\sigma')}$$

for $i = 2, \dots, n$.

Proof. First observe that if $\rho \notin \{\rho_1, \dots, \rho_{n+1}\}$, then ρ and τ never lie in the same cone of Σ , so that $D_\rho \cap V(\tau) = \emptyset$ by the Orbit-Cone Correspondence. This easily implies $D_\rho \cdot V(\tau) = 0$ (Exercise 6.3.1), which in turn implies that (6.3.6) reduces to the equation

$$(D_{\rho_1} \cdot V(\tau)) u_{\rho_1} + \sum_{i=2}^n (D_{\rho_i} \cdot V(\tau)) u_{\rho_i} + (D_{\rho_{n+1}} \cdot V(\tau)) u_{\rho_{n+1}} = 0.$$

The coefficients of u_{ρ_1} and $u_{\rho_{n+1}}$ are positive by (6.3.4), so up to a positive constant, this must be the wall relation (6.3.5). The first assertion of the lemma follows.

Since the above relation equals (6.3.5) up to a nonzero constant, we obtain

$$b_i (D_{\rho_1} \cdot V(\tau)) = \alpha (D_{\rho_i} \cdot V(\tau)), \quad b_i (D_{\rho_{n+1}} \cdot V(\tau)) = \beta (D_{\rho_i} \cdot V(\tau)),$$

for $i = 2, \dots, n$. Then the desired formulas for $D_{\rho_i} \cdot V(\tau)$ follow from (6.3.4). \square

For a simplicial toric variety, Lemmas 6.3.2 and 6.3.4 provide everything we need to compute $D \cdot V(\tau)$ when τ is a wall of Σ .

Example 6.3.5. Consider the fan Σ in \mathbb{R}^2 from Example 6.2.9. We have the wall

$$\tau = \text{Cone}(u_0) = \sigma \cap \sigma' = \text{Cone}(u_1, u_0) \cap \text{Cone}(u_2, u_0),$$

where $u_1 = e_1$, $u_2 = e_2$ and $u_0 = 2e_1 + 3e_2$. Computing multiplicities gives

$$\text{mult}(\tau) = 1, \text{mult}(\sigma) = 3, \text{mult}(\sigma') = 2.$$

Then Lemma 6.3.2 implies

$$D_1 \cdot V(\tau) = \frac{1}{3}, \quad D_2 \cdot V(\tau) = \frac{1}{2},$$

and the relation

$$2 \cdot u_1 + (-1) \cdot u_0 + 3 \cdot u_2 = 0$$

implies

$$D_0 \cdot V(\tau) = \frac{-1 \cdot 1}{2 \cdot 3} = \frac{-1 \cdot 1}{3 \cdot 2} = -\frac{1}{6}$$

by Lemma 6.3.4. Hence we recover the calculations of Example 6.2.9. \diamond

When X_Σ is smooth, all multiplicities are 1. Hence the wall relation (6.3.5) can be written uniquely as

$$(6.3.7) \quad u_{\rho_1} + \sum_{i=2}^n b_i u_{\rho_i} + u_{\rho_{n+1}} = 0,$$

and then the intersection formula of Lemma 6.3.4 reduces to

$$D_{\rho_i} \cdot V(\tau) = b_i$$

for $i = 2, \dots, n$.

Example 6.3.6. For the Hirzebruch surface \mathcal{H}_r , the four curves coming from walls are also divisors. Recall that the minimal generators are

$$u_1 = -e_1 + re_2, \quad u_2 = e_2, \quad u_3 = e_1, \quad u_4 = -e_2,$$

arranged clockwise around the origin (see Figure 3 from Example 6.1.3 for the case $r = 2$). Hence the wall generated by u_1 gives the relation

$$u_2 - 0 \cdot u_3 + u_4 = 0,$$

which implies

$$D_1 \cdot D_1 = 0$$

by Lemma 6.3.4. On the other hand, the wall generated by u_2 gives the relation

$$u_1 - r \cdot u_2 + u_3 = 0.$$

Then the lemma implies

$$D_2 \cdot D_2 = -r.$$

Similarly, one can check that

$$D_3 \cdot D_3 = 0, \quad D_4 \cdot D_4 = r,$$

and by Corollary 6.3.3 we also have

$$D_1 \cdot D_2 = D_2 \cdot D_3 = D_3 \cdot D_4 = D_4 \cdot D_1 = 1.$$

These computations give an explicit description of the duality between the nef and Mori cones shown in Figure 11 of Example 6.2.23 (Exercise 6.3.2). \diamond

In general, a divisor D on a complete surface has *self-intersection* $D \cdot D = D^2$. Self-intersections will play a prominent role in Chapter 10 when we study toric surfaces.

Primitive Collections. In the projective case, there is a beautiful criterion for a Cartier divisor to be nef or ample in terms of the *primitive collections* introduced in Definition 5.1.5. Recall that

$$P = \{\rho_1, \dots, \rho_k\} \subseteq \Sigma(1)$$

is a primitive collection if P is not contained in $\sigma(1)$ for some $\sigma \in \Sigma$ but any proper subset is. Since Σ is simplicial, primitive means that P does not generate a cone of Σ but every proper subset does. This is the definition given by Batyrev in [6].

Example 6.3.7. Consider the complete fan Σ in \mathbb{R}^3 shown in Figure 14.

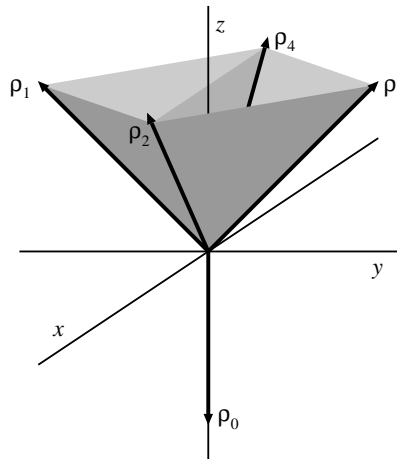

Figure 14. A fan in \mathbb{R}^3

One can check that

$$\{\rho_1, \rho_3\}, \{\rho_0, \rho_2, \rho_4\}$$

are the only primitive collections of Σ . \diamond

Here is the promised characterization, due to Batyrev [6] in the smooth case.

Theorem 6.3.8. Let X_Σ be a projective simplicial toric variety.

(a) A Cartier divisor D is nef if and only if its support function φ_D satisfies

$$\varphi_D(\mathbf{u}_{\rho_1} + \cdots + \mathbf{u}_{\rho_k}) \geq \varphi_D(\mathbf{u}_{\rho_1}) + \cdots + \varphi_D(\mathbf{u}_{\rho_k})$$

for all primitive collections $P = \{\rho_1, \dots, \rho_k\}$ of Σ .

(b) A Cartier divisor D is ample if and only if its support function φ_D satisfies

$$\varphi_D(\mathbf{u}_{\rho_1} + \cdots + \mathbf{u}_{\rho_k}) > \varphi_D(\mathbf{u}_{\rho_1}) + \cdots + \varphi_D(\mathbf{u}_{\rho_k})$$

for all primitive collections $P = \{\rho_1, \dots, \rho_k\}$ of Σ .

Before we discuss the proof of Theorem 6.3.8, we need to study the relations that come from primitive collections.

Definition 6.3.9. Let $P = \{\rho_1, \dots, \rho_k\} \subseteq \Sigma(1)$ be a primitive collection for the complete simplicial fan Σ . Hence $\sum_{i=1}^k \mathbf{u}_{\rho_i}$ lies in the relative interior of a cone $\gamma \in \Sigma$. Thus there is a unique expression

$$\mathbf{u}_{\rho_1} + \cdots + \mathbf{u}_{\rho_k} = \sum_{\rho \in \gamma(1)} c_\rho \mathbf{u}_\rho, \quad c_\rho \in \mathbb{Q}_{>0}.$$

Then $\mathbf{u}_{\rho_1} + \cdots + \mathbf{u}_{\rho_k} - \sum_{\rho \in \gamma(1)} c_\rho \mathbf{u}_\rho = 0$ is the **primitive relation** of P .

The coefficient vector of this relation is $r(P) = (b_\rho)_{\rho \in \Sigma(1)} \in \mathbb{R}^{\Sigma(1)}$, where

$$(6.3.8) \quad b_\rho = \begin{cases} 1 & \rho \in P, \rho \notin \gamma(1) \\ 1 - c_\rho & \rho \in P \cap \gamma(1) \\ -c_\rho & \rho \in \gamma(1), \rho \notin P \\ 0 & \text{otherwise.} \end{cases}$$

Then $\sum_\rho b_\rho \mathbf{u}_\rho = 0$, so that $r(P)$ gives an element of $N_1(X_\Sigma)$ by Proposition 6.3.1. In Exercise 6.3.3, you will prove that $c_\rho < 1$ when $\rho \in P \cap \gamma(1)$. This means that P is determined by the positive entries in the coefficient vector $r(P)$.

The Mori cone for X_Σ has a nice description in terms of primitive relations.

Theorem 6.3.10. For a projective simplicial toric variety X_Σ ,

$$\overline{NE}(X_\Sigma) = \sum_P \mathbb{R}_{\geq 0} r(P),$$

where the sum is over all primitive collections P of Σ .

Proof. Given a Cartier divisor $D = \sum_\rho a_\rho D_\rho$ and a relation $\sum_\rho b_\rho \mathbf{u}_\rho = 0$, the intersection pairing of $[D] \in \text{Pic}(X_\Sigma)_\mathbb{R}$ and $R = (b_\rho)_{\rho \in \Sigma(1)} \in N_1(X_\Sigma)$ is

$$(6.3.9) \quad [D] \cdot R = \sum_\rho a_\rho [D_\rho] \cdot R = \sum_\rho a_\rho b_\rho$$

(Exercise 6.3.4). In particular, when $R = r(P)$, we can rearrange terms to obtain

$$[D] \cdot r(P) = \sum_{i=1}^k a_{\rho_i} - \sum_{\rho \in \gamma(1)} a_{\rho} c_{\rho}.$$

Since the support function of D satisfies $\varphi_D(u_{\rho}) = -a_{\rho}$ and is linear on γ , we can rewrite this as

$$(6.3.10) \quad [D] \cdot r(P) = -\varphi_D(u_{\rho_1}) - \cdots - \varphi_D(u_{\rho_k}) + \varphi_D(u_{\rho_1} + \cdots + u_{\rho_k}).$$

If D is nef, then it is basepoint free (Theorem 6.2.12), so that φ_D is convex. It follows that $[D] \cdot r(P) \geq 0$, which proves $r(P) \in \overline{NE}(X_{\Sigma})$. Note also that $r(P)$ is nonzero.

To finish the proof, we need to show that $\overline{NE}(X_{\Sigma})$ is generated by the $r(P)$. In the discussion following the proof of Theorem 6.2.22, we noted that $\overline{NE}(X_{\Sigma})$ is generated by its extremal rays, each of which is of the form $\mathbb{R}_{\geq 0}[V(\tau)]$ for an extremal wall τ . It suffices to show that $[V(\tau)]$ is a positive multiple of $r(P)$ for some primitive collection P .

We first make a useful observation about nef divisors. Given a cone $\sigma \in \Sigma$, we claim that any nef divisor is linearly equivalent to a divisor of the form

$$(6.3.11) \quad D = \sum_{\rho} a_{\rho} D_{\rho}, \quad a_{\rho} = 0, \rho \in \sigma(1) \text{ and } a_{\rho} \geq 0, \rho \notin \sigma(1).$$

To prove this, first recall that any nef divisor is linearly equivalent to a torus-invariant nef divisor $D = \sum_{\rho} a_{\rho} D_{\rho}$. Then we have $m_{\sigma} \in M$ with $\langle m_{\sigma}, u_{\rho} \rangle = -a_{\rho}$ for $\rho \in \sigma(1)$. Since D is nef, it is also basepoint free, so that

$$\langle m_{\sigma}, u_{\rho} \rangle \geq \varphi_D(u_{\rho}) = -a_{\rho}, \quad \rho \in \Sigma(1),$$

by Theorem 6.1.10. Replacing D with $D + \text{div}(\chi^{m_{\sigma}})$, we obtain (6.3.11).

Now assume we have an extremal wall τ and let $C = V(\tau)$. Consider the set

$$P = \{\rho \mid D_{\rho} \cdot C > 0\}.$$

We will prove that P is a primitive collection whose primitive relation is the class of C , up to a positive constant. Our argument is taken from [37], which is based on ideas of Kresch [109].

We first prove by contradiction that $P \not\subseteq \sigma(1)$ for all $\sigma \in \Sigma$. Suppose $P \subseteq \sigma(1)$ and take an ample divisor D (remember that X_{Σ} is projective). Then in particular D is nef, so we may assume that D is of the form (6.3.11). Since $a_{\rho} = 0$ for $\rho \in \Sigma(1)$, we have

$$D \cdot C = \sum_{\rho \notin \sigma(1)} a_{\rho} D_{\rho} \cdot C.$$

However, $a_{\rho} \geq 0$ by (6.3.11), and $P \subseteq \sigma(1)$ implies $D_{\rho} \cdot C \leq 0$ for $\rho \notin \sigma(1)$. It follows that $D \cdot C \leq 0$, which is impossible since D is ample. Thus no cone of Σ contains all rays in P .

It follows that some subset $Q \subseteq P$ is a primitive collection. This gives the primitive relation with coefficient vector $r(Q) \in N_1(X_\Sigma)$, and we also have the class $[C] \in N_1(X_\Sigma)$. Let

$$\beta = [C] - \lambda r(Q) \in N_1(X_\Sigma),$$

where $\lambda > 0$. We claim that if λ is sufficiently small, then

$$(6.3.12) \quad \{\rho \mid [D_\rho] \cdot \beta < 0\} \subseteq \{\rho \mid D_\rho \cdot C < 0\}.$$

To prove this, first observe that the definition of β implies

$$D_\rho \cdot C = \lambda [D_\rho] \cdot r(Q) + [D_\rho] \cdot \beta.$$

Suppose that $[D_\rho] \cdot \beta < 0$ and $D_\rho \cdot C \geq 0$. This forces $[D_\rho] \cdot r(Q) > 0$. By (6.3.9), $[D_\rho] \cdot r(Q)$ is the coefficient of u_ρ in the primitive relation of Q , which by (6.3.8) is positive only when $\rho \in Q$. Then $Q \subseteq P$ implies $D_\rho \cdot C > 0$ by the definition of P . But we can clearly choose λ sufficiently small so that

$$D_\rho \cdot C > \lambda [D_\rho] \cdot r(Q) \quad \text{whenever } D_\rho \cdot C > 0.$$

This inequality and the above equation imply $[D_\rho] \cdot \beta > 0$, which is a contradiction.

We next claim that $\beta \in \overline{NE}(X_\Sigma)$. By (6.3.12), we have

$$\{\rho \mid [D_\rho] \cdot \beta < 0\} \subseteq \{\rho \mid D_\rho \cdot C < 0\} \subseteq \tau(1),$$

where the second inclusion follows from $C = V(\tau)$, (6.3.4), and Lemma 6.3.4. Now let D be nef, and by (6.3.11) with $\sigma = \tau$, we may assume that

$$D = \sum_{\rho} a_\rho D_\rho, \quad a_\rho = 0, \rho \in \tau(1) \quad \text{and} \quad a_\rho \geq 0, \rho \notin \tau(1).$$

Then

$$[D] \cdot \beta = \sum_{\rho \notin \tau(1)} a_\rho [D_\rho] \cdot \beta \geq 0,$$

where the final inequality follows since $a_\rho \geq 0$ and $[D_\rho] \cdot \beta < 0$ can happen only when $\rho \in \tau(1)$. This proves that $\beta \in \overline{NE}(X_\Sigma)$.

We showed earlier that $r(Q) \in \overline{NE}(X_\Sigma)$. Thus the equation

$$[C] = \lambda r(Q) + \beta$$

expresses $[C]$ as a sum of elements of $\overline{NE}(X_\Sigma)$. But $[C]$ is extremal, i.e., it lies in a 1-dimensional face of $\overline{NE}(X_\Sigma)$. By Lemma 1.2.7, this forces $r(Q)$ and β to lie in the face. Since $r(Q)$ is nonzero, it generates the face, so that $[C]$ is a positive multiple of $r(Q)$.

The relation corresponding to C has coefficients $(D_\rho \cdot C)_{\rho \in \Sigma(1)}$, and P is the set of ρ 's where $D_\rho \cdot C > 0$. But this relation is a positive multiple of $r(Q)$, whose positive entries correspond to Q . Thus $P = Q$ and the proof is complete. \square

It is now straightforward to prove Theorem 6.3.8 using Theorem 6.3.10 and (6.3.10) (Exercise 6.3.5). We should also mention that these results hold more generally for any projective toric variety (see [37]).

Example 6.3.11. Let Σ be the fan shown in Figure 14 of Example 6.3.7. The minimal generators of ρ_0, \dots, ρ_4 are

$$u_0 = (0, 0, -1), u_1 = (0, -1, 1), u_2 = (1, 0, 1), u_3 = (0, 1, 1), u_4 = (-1, 0, 1).$$

The computations you did for part (c) of Exercise 6.1.11 imply that X_Σ is projective. Since the only primitive collections are $\{\rho_1, \rho_3\}$ and $\{\rho_0, \rho_2, \rho_4\}$, Theorem 6.3.8 implies that a Cartier divisor D is nef if and only if

$$\begin{aligned} \varphi_D(u_1 + u_3) &\geq \varphi_D(u_1) + \varphi_D(u_3) \\ \varphi_D(u_0 + u_2 + u_4) &\geq \varphi_D(u_0) + \varphi_D(u_2) + \varphi_D(u_4) \end{aligned}$$

and ample if and only if these inequalities are strict. One can also check that

$$\text{Pic}(X_\Sigma) \simeq \{a[D_1] + b[D_2] \mid a, b \in 2\mathbb{Z}\}$$

and $aD_1 + bD_2$ is nef (resp. ample) if and only if $a \geq b \geq 0$ (resp. $a > b > 0$). Exercise 6.3.6 will relate this example to the proof of Theorem 6.3.10.

Besides Σ , the minimal generators u_0, \dots, u_4 support two other complete fans in \mathbb{R}^3 : first, the fan Σ' obtained by replacing $\text{Cone}(u_2, u_3)$ with $\text{Cone}(u_1, u_3)$ in Figure 14, and second, the fan Σ_0 obtained by removing this wall to create the cone $\text{Cone}(u_1, u_2, u_3, u_4)$. Since $\Sigma(1) = \Sigma'(1) = \Sigma_0(1)$, the toric varieties $X_\Sigma, X_{\Sigma'}, X_{\Sigma_0}$ have the same class group, though X_{Σ_0} has strictly smaller Picard group since it is not simplicial. Thus

$$\text{Pic}(X_{\Sigma_0})_{\mathbb{R}} \subseteq \text{Pic}(X_\Sigma)_{\mathbb{R}} = \text{Pic}(X_{\Sigma'})_{\mathbb{R}} \simeq \mathbb{R}^2.$$

This allows us to draw all three nef cones in the same copy of \mathbb{R}^2 . In Exercise 6.3.6 you show that we get the cones shown in Figure 15. The ideas behind this figure

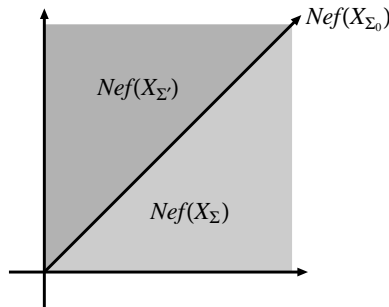

Figure 15. The nef cones of $X_\Sigma, X_{\Sigma'}, X_{\Sigma_0}$

will be developed in Chapters 14 and 15 when we study geometric invariant theory and the minimal model program for toric varieties. \diamond

Exercises for §6.3.

6.3.1. This exercise will describe a situation where $D \cdot C$ is guaranteed to be zero.

- (a) Let X be normal and assume that C is a complete irreducible curve disjoint from the support of a Cartier divisor D . Prove that $D \cdot C = 0$. Hint: Use $U = X \setminus \text{Supp}(D)$.
- (b) Let τ be a wall of a fan Σ and pick $\rho \in \Sigma(1)$ such that ρ and τ never lie in the same cone of Σ . Use the Cone-Orbit Correspondence to prove that $D_\rho \cap V(\tau) = \emptyset$, and conclude that $D_\rho \cdot V(\tau) = 0$.

6.3.2. As in Example 6.3.2, the classes $[D_3], [D_4]$ give a basis of $\text{Pic}(\mathcal{H}_r)_\mathbb{R}$. Since \mathcal{H}_r is a smooth complete surface, the intersection product $D_i \cdot V(\tau_j)$ is written $D_i \cdot D_j$.

- (a) Give an explicit formula for $(a[D_3] + b[D_4]) \cdot (a[D_3] + b[D_4])$ using the computations of Example 6.3.2.
- (b) Use part (a) to show that the cones shown in Figure 11 in Example 6.2.23 are dual to each other.

6.3.3. In the primitive relation defined in Definition 6.3.9, prove $c_\rho < 1$ when $\rho \in P \cap \gamma(1)$. Hint: If $\rho_1 \in \gamma(1)$ and $c_{\rho_1} \geq 1$, then cancel u_{ρ_1} and show that $u_{\rho_2}, \dots, u_{\rho_k} \in \gamma$.

6.3.4. Let X_Σ be a simplicial toric variety and fix a Cartier divisor $D = \sum_\rho a_\rho D_\rho$ and a relation $\sum_\rho b_\rho u_\rho = 0$. Prove that the intersection pairing of $[D] \in \text{Pic}(X_\Sigma)_\mathbb{R}$ and $R = (b_\rho)_{\rho \in \Sigma(1)} \in N_1(X_\Sigma)$ is $[D] \cdot R = \sum_\rho a_\rho b_\rho$.

6.3.5. Prove Theorem 6.3.8 using Theorem 6.3.10 and (6.3.10).

6.3.6. Consider the fan Σ from Examples 6.3.7 and 6.3.11. Every wall of Σ is of the form $\tau_{ij} = \text{Cone}(u_i, u_j)$ for suitable $i < j$. Let $r(\tau_{ij}) \in \mathbb{R}^5$ denote the wall relation of τ_{ij} . Normalize by a positive constant so that the entries of $r(\tau_{ij})$ are integers with $\text{gcd} = 1$.

- (a) Show the nine walls give the three distinct wall relations $r(\tau_{02}), r(\tau_{03}), r(\tau_{24})$.
- (b) Show that $r(\tau_{03}) + r(\tau_{24}) = r(\tau_{02})$ and conclude that τ_{03} and τ_{24} are extremal walls whose classes generate the Mori cone of X_Σ .
- (c) For each extremal wall of part (b), determine the corresponding primitive collection. You should be able to read the primitive collection directly from the wall relation.
- (d) Show that the nef cones of $X_\Sigma, X_{\Sigma'}, X_{\Sigma_0}$ give the cones shown in Figure 15.

6.3.7. Let X_Σ be the blowup of \mathbb{P}^n at a fixed point of the torus action. Thus $\text{Pic}(X_\Sigma) \simeq \mathbb{Z}^2$.

- (a) Compute the nef and Mori cones of X_Σ and draw pictures similar to Figure 11 in Example 6.2.23.
- (b) Determine the primitive relations and extremal walls of X_Σ .

6.3.8. Let \mathcal{P}_r be the toric surface obtained by changing the ray u_1 in the fan of the Hirzebruch surface \mathcal{H}_r from $(-1, r)$ to $(-r, 1)$. Assume $r > 1$.

- (a) Prove that \mathcal{P}_r is singular. How many singular points are there?
- (b) Determine which divisors $a_1 D_1 + a_2 D_2 + a_3 D_3 + a_4 D_4$ are Cartier and compute $D_i \cdot D_j$ for all i, j .
- (c) Determine the primitive relations and extremal walls of \mathcal{P}_r .

Appendix: Quasicoherent Sheaves on Toric Varieties

Now that we know more about sheaves (specifically, tensor products and exactness), we can complete the discussion of quasicoherent sheaves on toric varieties begun in §5.3. In this appendix, X_Σ will denote a toric variety with no torus factors. The total coordinate ring of X_Σ is $S = \mathbb{C}[x_\rho \mid \rho \in \Sigma(1)]$, which is graded by $\text{Cl}(X_\Sigma)$.

Recall from §5.3 that for $\alpha \in \text{Cl}(X_\Sigma)$, the shifted S -module $S(\alpha)$ gives the sheaf $\mathcal{O}_{X_\Sigma}(\alpha)$ satisfying $\mathcal{O}_{X_\Sigma}(\alpha) \simeq \mathcal{O}_{X_\Sigma}(D)$ for any Weil divisor with $\alpha = [D]$. In §6.0 we constructed a sheaf homomorphism $\mathcal{O}_X(D) \otimes_{\mathcal{O}_X} \mathcal{O}_X(E) \rightarrow \mathcal{O}_X(D+E)$. In a similar way, one can define

$$(6.A.1) \quad \mathcal{O}_{X_\Sigma}(\alpha) \otimes_{\mathcal{O}_{X_\Sigma}} \mathcal{O}_{X_\Sigma}(\beta) \longrightarrow \mathcal{O}_{X_\Sigma}(\alpha + \beta).$$

for $\alpha, \beta \in \text{Cl}(X_\Sigma)$ such that if $\alpha = [D]$ and $\beta = [E]$, then the diagram

$$\begin{array}{ccc} \mathcal{O}_{X_\Sigma}(D) \otimes_{\mathcal{O}_{X_\Sigma}} \mathcal{O}_{X_\Sigma}(E) & \longrightarrow & \mathcal{O}_{X_\Sigma}(D+E) \\ \downarrow & & \downarrow \\ \mathcal{O}_{X_\Sigma}(\alpha) \otimes_{\mathcal{O}_{X_\Sigma}} \mathcal{O}_{X_\Sigma}(\beta) & \longrightarrow & \mathcal{O}_{X_\Sigma}(\alpha + \beta) \end{array}$$

commutes, where the vertical maps are isomorphisms.

From Sheaves to Modules. The main construction of §5.3 takes a graded S -module M and produces a quasicoherent sheaf \tilde{M} on X_Σ . We now go in the reverse direction and show that every quasicoherent sheaf on X_Σ arises in this way. We will use the following construction.

Definition 6.A.1. For a sheaf \mathcal{F} of \mathcal{O}_{X_Σ} -modules on X_Σ and $\alpha \in \text{Cl}(X_\Sigma)$, define

$$\mathcal{F}(\alpha) = \mathcal{F} \otimes_{\mathcal{O}_{X_\Sigma}} \mathcal{O}_{X_\Sigma}(\alpha)$$

and then set

$$\Gamma_*(\mathcal{F}) = \bigoplus_{\alpha \in \text{Cl}(X_\Sigma)} \Gamma(X_\Sigma, \mathcal{F}(\alpha)).$$

For example, $\Gamma_*(\mathcal{O}_{X_\Sigma}) = S$ since $\Gamma(X_\Sigma, \mathcal{O}_{X_\Sigma}(\alpha)) \simeq S_\alpha$ by Proposition 5.3.7. Using this and (6.A.1), we see that $\Gamma_*(\mathcal{F})$ is a graded S -module.

We want to show that \mathcal{F} is isomorphic to the sheaf associated to $\Gamma_*(\mathcal{F})$ when \mathcal{F} is quasicoherent. We will need the following lemma due to Mustață [130]. Recall that for $\sigma \in \Sigma$, we have the monomial $x^{\hat{\sigma}} = \prod_{\rho \notin \sigma(1)} x_\rho \in S$. Let $\alpha_\sigma = \deg(x^{\hat{\sigma}}) \in \text{Cl}(X_\Sigma)$.

Lemma 6.A.2. Let \mathcal{F} be a quasicoherent sheaf on X_Σ .

- If $v \in \Gamma(U_\sigma, \mathcal{F})$, then there are $\ell \geq 0$ and $u \in \Gamma(X_\Sigma, \mathcal{F}(\ell\alpha_\sigma))$ such that u restricts to $(x^{\hat{\sigma}})^\ell v \in \Gamma(U_\sigma, \mathcal{F}(\ell\alpha_\sigma))$.
- If $u \in \Gamma(X_\Sigma, \mathcal{F})$ restricts to 0 in $\Gamma(U_\sigma, \mathcal{F})$, then there is $\ell \geq 0$ such that $(x^{\hat{\sigma}})^\ell u = 0$ in $\Gamma(X_\Sigma, \mathcal{F}(\ell\alpha_\sigma))$.

Proof. For part (a), fix $\sigma \in \Sigma$ and take $v \in \Gamma(U_\sigma, \mathcal{F})$. Given $\tau \in \Sigma$, let v_τ be the restriction of v to $U_\sigma \cap U_\tau$. By (3.1.3), we can find $m \in (-\sigma^\vee) \cap \tau^\vee \cap M$ such that $U_\sigma \cap U_\tau = (U_\tau)_{x^m} = \text{Spec}(\mathbb{C}[\tau^\vee \cap M]_{x^m})$. In terms of the total coordinate ring S , we have $\mathbb{C}[\tau^\vee \cap M] \simeq (S_{x^{\hat{\tau}}})_0$ by (5.3.1). Hence the coordinate ring of $U_\sigma \cap U_\tau$ is the localization

$$\left((S_{x^{\hat{\tau}}})_0 \right)_{x^{(m)}},$$

where $x^{(m)} = \prod_{\rho} x_{\rho}^{(m, u_{\rho})} \in (S_{x^{\hat{\tau}}})_0$ since $m \in \tau^{\vee} \cap M$. This enables us to write

$$U_{\sigma} \cap U_{\tau} = (U_{\tau})_{x^{(m)}}.$$

Since \mathcal{F} is quasicohherent, $\mathcal{F}|_{U_{\tau}}$ is determined by its sections $G = \Gamma(U_{\tau}, \mathcal{F})$, and then $\Gamma(U_{\sigma} \cap U_{\tau}, \mathcal{F})$ is the localization $G_{x^{(m)}}$.

It follows that $v_{\tau} \in \Gamma(U_{\sigma}, \mathcal{F})$ equals $\tilde{u}_{\tau}/(x^{(m)})^k$, where $k \geq 0$ and $\tilde{u}_{\tau} \in \Gamma(U_{\tau}, \mathcal{F})$. Hence \tilde{u}_{τ} restricts to $(x^{(m)})^k v \in \Gamma(U_{\sigma}, \mathcal{F})$. Since $m \in (-\sigma^{\vee})$, we see that

$$(6.A.2) \quad x^a = (x^{\hat{\sigma}})^{\ell} (x^{(m)})^{-k} \in S$$

for $\ell \gg 0$. This monomial has degree $\ell \alpha_{\sigma}$. Then $u_{\tau} = x^a \tilde{u}_{\tau} \in \Gamma(U_{\tau}, \mathcal{F}(\ell \alpha_{\sigma}))$ restricts to $(x^{\hat{\sigma}})^{\ell} v_{\tau} \in \Gamma(U_{\sigma} \cap U_{\tau}, \mathcal{F}(\ell \alpha_{\sigma}))$. By making ℓ sufficiently large, we can find one ℓ that works for all $\tau \in \Sigma$.

To study whether the u_{τ} patch to give a global section of $\mathcal{F}(\ell \alpha_{\sigma})$, take $\tau_1, \tau_2 \in \Sigma$ and set $\gamma = \tau_1 \cap \tau_2$. Thus $U_{\gamma} = U_{\tau_1} \cap U_{\tau_2}$, and

$$(6.A.3) \quad w = u_{\tau_1}|_{U_{\gamma}} - u_{\tau_2}|_{U_{\gamma}} \in \Gamma(U_{\gamma}, \mathcal{F}(\ell \alpha_{\sigma}))$$

restricts to $0 \in \Gamma(U_{\sigma} \cap U_{\gamma}, \mathcal{F}(\ell \alpha_{\sigma}))$. Arguing as above, this group of sections is the localization $\Gamma(U_{\gamma}, \mathcal{F}(\ell \alpha_{\sigma}))_{x^{(m)}}$, where $m \in \gamma^{\vee} \cap (-\sigma^{\vee}) \cap M$ such that $U_{\sigma} \cap U_{\gamma} = (U_{\gamma})_{x^m}$. Since w gives the zero element in this localization, there is $k \geq 0$ with $(x^{(m)})^k w = 0$ in $\Gamma(U_{\gamma}, \mathcal{F}(\ell \alpha_{\sigma}))$. If we multiply by $x^b = (x^{\hat{\sigma}})^{\ell'} (x^{(m)})^{-k}$ for $\ell' \gg 0$, we obtain $(x^{\hat{\sigma}})^{\ell'} w = 0$ in $\Gamma(U_{\gamma}, \mathcal{F}((\ell' + \ell)\alpha_{\sigma}))$. Another way to think of this is that if we made ℓ in (6.A.2) big enough to begin with, then in fact $w = 0$ in $\Gamma(U_{\gamma}, \mathcal{F}(\ell \alpha_{\sigma}))$ for all τ, τ' . Given the definition (6.A.3) of w , it follows that the u_{τ} patch to give a global section $u \in \Gamma(X_{\Sigma}, \mathcal{F}(\ell \alpha_{\sigma}))$ with the desired properties.

The proof of part (b) is similar and is left to the reader. \square

Proposition 6.A.3. *Let \mathcal{F} be a quasicohherent sheaf on X_{Σ} . Then \mathcal{F} is isomorphic to the sheaf associated to the graded S -module $\Gamma_*(\mathcal{F})$.*

Proof. Let $M = \Gamma_*(\mathcal{F})$ and recall from §5.3 that for every $\sigma \in \Sigma$, the restriction of \tilde{M} to U_{σ} is the sheaf associated to the $(S_{x^{\hat{\sigma}}})_0$ -module $(M_{x^{\hat{\sigma}}})_0$.

We first construct a sheaf homomorphism $\tilde{M} \rightarrow \mathcal{F}$. Elements of $(M_{x^{\hat{\sigma}}})_0$ are $u/(x^{\hat{\sigma}})^{\ell}$ for $u \in \Gamma(X_{\Sigma}, \mathcal{F}(\ell \alpha_{\sigma}))$. Since $(x^{\hat{\sigma}})^{-\ell}$ is a section of $\mathcal{O}_{X_{\Sigma}}(-\ell \alpha_{\sigma})$ over U_{σ} , the map

$$\Gamma(U_{\sigma}, \mathcal{O}_{X_{\Sigma}}(-\ell \alpha_{\sigma})) \otimes_{\mathbb{C}} \Gamma(U_{\sigma}, \mathcal{F}(\ell \alpha_{\sigma})) \longrightarrow \Gamma(U_{\sigma}, \mathcal{F})$$

induces a homomorphism of $(S_{x^{\hat{\sigma}}})_0$ -modules

$$(6.A.4) \quad (M_{x^{\hat{\sigma}}})_0 \longrightarrow \Gamma(U_{\sigma}, \mathcal{F}).$$

This gives compatible sheaf homomorphisms $\tilde{M}|_{U_{\sigma}} \rightarrow \mathcal{F}|_{U_{\sigma}}$ that patch to give $\tilde{M} \rightarrow \mathcal{F}$.

Since \mathcal{F} is quasicohherent, it suffices to show that (6.A.4) is an isomorphism for every $\sigma \in \Sigma$. First suppose that $u/(x^{\hat{\sigma}})^k \in (M_{x^{\hat{\sigma}}})_0$ maps to $0 \in \Gamma(U_{\sigma}, \mathcal{F})$. It follows easily that u restricts to zero in $\Gamma(U_{\sigma}, \mathcal{F}(k \alpha_{\sigma}))$. By Lemma 6.A.2 applied to $\mathcal{F}(k \alpha_{\sigma})$, there is $\ell \geq 0$ such that $(x^{\hat{\sigma}})^{\ell} u = 0$ in $\Gamma(X_{\Sigma}, \mathcal{F}((\ell + k)\alpha_{\sigma}))$. Then

$$\frac{u}{(x^{\hat{\sigma}})^k} = \frac{(x^{\hat{\sigma}})^{\ell} u}{(x^{\hat{\sigma}})^{\ell+k}} = 0 \quad \text{in } (M_{x^{\hat{\sigma}}})_0,$$

which shows that (6.A.4) is injective. To prove surjectivity, take $v \in \Gamma(U_\sigma, \mathcal{F})$ and apply Lemma 6.A.2 to find $\ell \geq 0$ and $u \in \Gamma(X_\Sigma, \mathcal{F}(\ell\alpha_\sigma))$ such that u restricts to $(x^{\hat{\sigma}})^\ell v$. It follows immediately that $u/(x^{\hat{\sigma}})^\ell \in (M_{x^{\hat{\sigma}}})_0$ maps to v . \square

This result proves part (a) of Proposition 5.3.9. We now turn our attention to part (b) of the proposition, which applies to coherent sheaves.

Proposition 6.A.4. *Every coherent sheaf \mathcal{F} on X_Σ is isomorphic to the sheaf associated to a finitely generated graded S -module.*

Proof. On the affine open subset U_σ , we can find finitely many sections $f_{i,\sigma} \in \Gamma(U_\sigma, \mathcal{F})$ which generate \mathcal{F} over U_σ . By Lemma 6.A.2, we can find $\ell \geq 0$ such that $(x^{\hat{\sigma}})^\ell f_{i,\sigma}$ comes from a global section $g_{i,\sigma}$ of $\mathcal{F}(\ell\alpha_\sigma)$. Now consider the graded S -module $M \subseteq \Gamma_*(\mathcal{F})$ generated by the $g_{i,\sigma}$. Proposition 6.A.3 gives an isomorphism

$$\widetilde{\Gamma_*(\mathcal{F})} \simeq \mathcal{F}.$$

Hence $M \subseteq \Gamma_*(\mathcal{F})$ gives a sheaf homomorphism $\widetilde{M} \rightarrow \mathcal{F}$ which is injective by the exactness proved in Example 6.0.10. Over U_σ , we have $f_{i,\sigma} = g_{i,\sigma}/(x^{\hat{\sigma}})^\ell \in (M_{x^{\hat{\sigma}}})_0$, and since these sections generate \mathcal{F} over U_σ , it follows that $\widetilde{M} \simeq \mathcal{F}$. Then we are done since M is clearly finitely generated. \square

The proof of Proposition 6.A.4 used a submodule of $\Gamma_*(\mathcal{F})$ because the full module need not be finitely generated when \mathcal{F} is coherent. Here is an easy example.

Example 6.A.5. A point $p \in \mathbb{P}^n$ gives a subvariety $i : \{p\} \hookrightarrow \mathbb{P}^n$. The sheaf $\mathcal{F} = i_* \mathcal{O}_{\{p\}}$ can be thought of as a copy of \mathbb{C} sitting over the point p . The line bundle $\mathcal{O}_{\mathbb{P}^n}(a)$ is free in a neighborhood of p , so that $\mathcal{F}(a) \simeq \mathcal{F}$ for all $a \in \mathbb{Z}$. Thus

$$\Gamma_*(\mathcal{F}) = \bigoplus_{a \in \mathbb{Z}} \Gamma(\mathbb{P}^n, \mathcal{F}(a)) = \bigoplus_{a \in \mathbb{Z}} \mathbb{C}.$$

This module is not finitely generated over S since it is nonzero in all negative degrees. \diamond

Subschemes and Homogeneous Ideals. For readers who know about schemes, we can apply the above results to describe subschemes of a toric variety X_Σ with no torus factors.

Let $I \subseteq S$ be a homogeneous ideal. By Proposition 6.0.10, this gives a sheaf of ideals $\mathcal{I} \subseteq \mathcal{O}_{X_\Sigma}$ whose quotient is the structure sheaf of closed subscheme of $Y \subseteq X_\Sigma$. This differs from the subvarieties considered in the rest of the book since the structure sheaf \mathcal{O}_Y may have nilpotents.

Proposition 6.A.6. *Every subscheme $Y \subseteq X_\Sigma$ is defined by a homogeneous ideal $I \subseteq S$.*

Proof. Given an ideal sheaf $\mathcal{I} \subseteq \mathcal{O}_{X_\Sigma}$, we get a homomorphism of S -modules

$$\Gamma_*(\mathcal{I}) \longrightarrow \Gamma_*(\mathcal{O}_{X_\Sigma}) = S.$$

If $I \subseteq S$ is the image of this map, then the map factors $\Gamma_*(\mathcal{I}) \twoheadrightarrow I \hookrightarrow S$, where the first arrow is surjective and the second injective. By Example 6.0.10 and Proposition 6.A.3, the inclusion $\mathcal{I} \subseteq \mathcal{O}_{X_\Sigma}$ factors as $\mathcal{I} \twoheadrightarrow \tilde{I} \hookrightarrow \mathcal{O}_{X_\Sigma}$. It follows immediately that $\mathcal{I} = \tilde{I}$. \square

In the case of \mathbb{P}^n , it is well-known that different graded ideals can give the same ideal sheaf. The same happens in the toric situation, and as in §5.3, we get the best answer in the smooth case. Not surprisingly, the irrelevant ideal $B(\Sigma) \subseteq S$ plays a key role.

Proposition 6.A.7. *Homogeneous ideals $I, J \subseteq S$ in the total coordinate of a smooth toric variety X_Σ give the same ideal sheaf of \mathcal{O}_{X_Σ} if and only if $I : B(\Sigma)^\infty = J : B(\Sigma)^\infty$.*

Proof. Since I is homogeneous, the same is true for $I : B(\Sigma)^\infty$, and in the exact sequence

$$0 \longrightarrow I \longrightarrow I : B(\Sigma)^\infty \longrightarrow I : B(\Sigma)^\infty / I \longrightarrow 0,$$

the quotient $I : B(\Sigma)^\infty / I$ is annihilated by a power of $B(\Sigma)$ since I is finitely generated. The sheaf associated to this quotient is trivial by Proposition 5.3.10. Then I and $I : B(\Sigma)^\infty$ give the same ideal sheaf by Example 6.0.10. This proves one direction of the proposition.

For the converse, suppose that I and J give the same ideal sheaf. This means that

$$(I_{x^{\hat{\sigma}}})_0 = (J_{x^{\hat{\sigma}}})_0$$

for all $\sigma \in \Sigma$. Take $f \in I_\alpha$ for $\alpha \in \text{Cl}(X_\Sigma)$ and fix $\sigma \in \Sigma$. Arguing as in the proof of Proposition 5.3.10, we can find a monomial x^b involving only x_ρ for $\rho \notin \sigma(1)$ such that $x^b f / (x^{\hat{\sigma}})^k \in (I_{x^{\hat{\sigma}}})_0$. This implies $x^b f / (x^{\hat{\sigma}})^k \in (J_{x^{\hat{\sigma}}})_0$, which in turn easily implies that $(x^{\hat{\sigma}})^\ell f \in J$ for $\ell \gg 0$. Thus $I \subseteq J : B(\Sigma)^\infty$, and from here the rest of the proof is straightforward. \square

There is a less elegant version of this result that applies to simplicial toric varieties. See [33] for a proof and more details about the relation between graded modules and sheaves. See also [123] for more on multigraded commutative algebra.

Projective Toric Morphisms

§7.0. Background: Quasiprojective Varieties and Projective Morphisms

Many results of Chapter 6 can be generalized, but in order to do so, we need to learn about *quasiprojective varieties* and *projective morphisms*.

Quasiprojective Varieties. Besides affine and projective varieties, we also have the following important class of varieties.

Definition 7.0.1. A variety is *quasiprojective* if it is isomorphic to an open subset of a projective variety.

Here are some easy properties of quasiprojective varieties.

Proposition 7.0.2.

- (a) *Affine varieties and projective varieties are quasiprojective.*
- (b) *Every closed subvariety of a quasiprojective variety is quasiprojective.*
- (c) *A product of quasiprojective varieties is quasiprojective.*

Proof. You will prove this in Exercise 7.0.1. □

Projective Morphisms. In algebraic geometry, concepts that apply to varieties sometimes have relative versions that apply to morphisms between varieties. For example, in §3.4, we defined *completeness* and *properness*, where the former applies to varieties and the latter applies to morphisms. Sometimes we say that the

relative version of a complete variety is a proper morphism. In the same way, the relative version of a *projective variety* is a *projective morphism*.

We begin with a special case. Let $f : X \rightarrow Y$ be a morphism and \mathcal{L} a line bundle on X with a basepoint free finite-dimensional subspace $W \subseteq \Gamma(X, \mathcal{L})$. Then combining $f : X \rightarrow Y$ with the morphism $\phi_{\mathcal{L}, W} : X \rightarrow \mathbb{P}(W^\vee)$ from §6.0 gives a morphism $X \rightarrow Y \times \mathbb{P}(W^\vee)$ that fits into a commutative diagram

$$(7.0.1) \quad \begin{array}{ccc} X & \xrightarrow{f \times \phi_{\mathcal{L}, W}} & Y \times \mathbb{P}(W^\vee) \\ & \searrow f & \downarrow p_1 \\ & & Y \end{array}$$

If $f \times \phi_{\mathcal{L}, W}$ is a *closed embedding* (meaning that its image $Z \subseteq Y \times \mathbb{P}(W^\vee)$ is closed and the induced map $X \rightarrow Z$ is an isomorphism), then you will show in Exercise 7.0.2 that f has the following nice properties:

- f is proper.
- For every $p \in Y$, the fiber $f^{-1}(p)$ is isomorphic to a closed subvariety of $\mathbb{P}(W^\vee)$ and hence is projective.

The general definition of projective morphism must include this special case. In fact, going from the special case to the general case is not that hard.

Definition 7.0.3. A morphism $f : X \rightarrow Y$ is **projective** if there is a line bundle \mathcal{L} on X and an affine open cover $\{U_i\}$ of Y with the property that for each i , there is a basepoint free finite-dimensional subspace $W_i \subseteq \Gamma(f^{-1}(U_i), \mathcal{L})$ such that

$$f^{-1}(U_i) \xrightarrow{f_i \times \phi_{\mathcal{L}_i, W_i}} U_i \times \mathbb{P}(W_i^\vee)$$

is a closed embedding, where $f_i = f|_{f^{-1}(U_i)}$ and $\mathcal{L}_i = \mathcal{L}|_{f^{-1}(U_i)}$. We say that $f : X \rightarrow Y$ is **projective with respect to \mathcal{L}** .

The general case has the properties noted above in the special case.

Proposition 7.0.4. *Let $f : X \rightarrow Y$ be projective. Then:*

- (a) f is proper.
- (b) For every $p \in Y$, the fiber $f^{-1}(p)$ is a projective variety. □

Here are some further properties.

Proposition 7.0.5.

- (a) The composition of projective morphisms is projective.
- (b) A closed embedding is a projective morphism.
- (c) A variety X is projective if and only if $X \rightarrow \{\text{pt}\}$ is a projective morphism.

Proof. Parts (a) and (b) are proved in [73, (5.5.5)]. For part (c), one direction follows immediately from the previous proposition. Conversely, let $i : X \hookrightarrow \mathbb{P}^n$ be projective, and assume that X is *nondegenerate*, meaning that X is not contained in any hyperplane of \mathbb{P}^n . Now let $\mathcal{L} = \mathcal{O}_X(1) = i^* \mathcal{O}_{\mathbb{P}^n}(1)$. Then

$$i^* : \Gamma(\mathbb{P}^n, \mathcal{O}_{\mathbb{P}^n}(1)) \longrightarrow \Gamma(X, \mathcal{L})$$

is injective since X is nondegenerate. In Exercise 7.0.3 you will show that

$$\Gamma(\mathbb{P}^n, \mathcal{O}_{\mathbb{P}^n}(1)) = \text{Span}(x_0, \dots, x_n)$$

and that if $W \subseteq \Gamma(X, \mathcal{L})$ is the image of i^* , then $\phi_{\mathcal{L}, W}$ is the embedding we began with. Hence Definition 7.0.3 is satisfied for $X \rightarrow \{\text{pt}\}$ and \mathcal{L} . \square

When the domain is quasiprojective, the relation between proper and projective is especially easy to understand.

Proposition 7.0.6. *Let $f : X \rightarrow Y$ be a morphism where X is quasiprojective. Then:*

$$f \text{ is proper} \iff f \text{ is projective.}$$

Proof. One direction is obvious since projective implies proper. For the opposite direction, X is quasiprojective, which implies that there is a morphism

$$g : X \longrightarrow Z$$

such that Z is projective, $g(X) \subseteq Z$ is open, and $X \simeq g(X)$ via g . Then one can prove without difficulty that the product map

$$(7.0.2) \quad f \times g : X \longrightarrow Y \times Z$$

induces an isomorphism $X \simeq (f \times g)(X)$.

Since $f : X \rightarrow Y$ is proper, $f \times g : X \rightarrow Y \times Z$ is also proper (Exercise 7.0.4). Hence the image of $f \times g$ is closed in $X \times Z$ since proper morphisms are universally closed. Thus $X \simeq (f \times g)(X)$ and $(f \times g)(X)$ is closed in $Y \times Z$. This proves that (7.0.2) is a closed embedding.

Now take a closed embedding $Z \hookrightarrow \mathbb{P}^s$. Arguing as above, we get a closed embedding of X into $Y \times \mathbb{P}^s$. From here, it is straightforward to show that f is projective (Exercise 7.0.4). \square

To complicate matters, there are two definitions of projective morphism used in the literature. In [77, II.4], a projective morphism is defined as the special case considered in (7.0.1), while [73, (5.5.2)] and [171, 5.3] give a much more general definition. Theorem 7.A.5 of the appendix to this chapter shows that the more general definition is equivalent to Definition 7.0.3.

Projective Bundles. Vector bundles give rise to an interesting class of projective morphisms.

Let $\pi : V \rightarrow X$ be a vector bundle of rank $n \geq 1$. Recall from §6.0 that V has a trivialization $\{(U_i, \phi_i)\}$ with $\phi_i : \pi^{-1}(U_i) \simeq U_i \times \mathbb{C}^n$. Furthermore, the transition functions $g_{ij} \in \mathrm{GL}_n(\Gamma(U_i \cap U_j, \mathcal{O}_X))$ that make the diagram

$$\begin{array}{ccc}
 & & U_i \cap U_j \times \mathbb{C}^n \\
 \phi_i|_{\pi^{-1}(U_i \cap U_j)} & \nearrow & \uparrow 1 \times g_{ij} \\
 \pi^{-1}(U_i \cap U_j) & & U_i \cap U_j \times \mathbb{C}^n \\
 \phi_j|_{\pi^{-1}(U_i \cap U_j)} & \searrow &
 \end{array}$$

commute. Note that $1 \times g_{ij}$ induces an isomorphism

$$1 \times \bar{g}_{ij} : U_i \cap U_j \times \mathbb{P}^{n-1} \simeq U_i \cap U_j \times \mathbb{P}^{n-1}.$$

This gives gluing data for a variety $\mathbb{P}(V)$. It is clear that π induces a morphism $\bar{\pi} : \mathbb{P}(V) \rightarrow X$ and that ϕ_i induces the trivialization

$$\bar{\phi}_i : \bar{\pi}^{-1}(U_i) \simeq U_i \times \mathbb{P}^{n-1}.$$

The discussion following Theorem 7.A.5 in the appendix to this chapter shows that $\bar{\pi} : \mathbb{P}(V) \rightarrow X$ is a projective morphism. We call $\mathbb{P}(V)$ the *projective bundle* of V .

Example 7.0.7. Let W be a finite-dimensional vector space over \mathbb{C} of positive dimension. Then, for any variety X , the trivial bundle $X \times W \rightarrow X$ gives the trivial projective bundle $X \times \mathbb{P}(W) \rightarrow X$. \diamond

There is also a version of this construction for locally free sheaves. If \mathcal{E} is locally free of rank n , then \mathcal{E} is the sheaf of sections of a vector bundle $V_{\mathcal{E}} \rightarrow X$ of rank n . When $n = 1$, we proved this in Theorem 6.0.20. Then define

$$(7.0.3) \quad \mathbb{P}(\mathcal{E}) = \mathbb{P}(V_{\mathcal{E}}^{\vee}),$$

where $V_{\mathcal{E}}^{\vee}$ is the dual vector bundle of $V_{\mathcal{E}}$. Here are some properties of $\mathbb{P}(\mathcal{E})$.

Lemma 7.0.8.

- (a) $\mathbb{P}(\mathcal{L}) = X$ when \mathcal{L} is locally free of rank 1.
- (b) $\mathbb{P}(\mathcal{E} \otimes_{\mathcal{O}_X} \mathcal{L}) = \mathbb{P}(\mathcal{E})$ when \mathcal{E} is locally free and \mathcal{L} is a line bundle.
- (c) If a homomorphism $\mathcal{E} \rightarrow \mathcal{F}$ of locally free sheaves is surjective, then the induced map $\mathbb{P}(\mathcal{F}) \rightarrow \mathbb{P}(\mathcal{E})$ of projective bundles is injective.

Proof. You will prove this in Exercise 7.0.5. The dual in (7.0.3) explains why $\mathcal{E} \rightarrow \mathcal{F}$ gives $\mathbb{P}(\mathcal{F}) \rightarrow \mathbb{P}(\mathcal{E})$. \square

The appearance of the dual in (7.0.3) can be explained as follows. Let \mathcal{L} be a line bundle with $W \subseteq \Gamma(X, \mathcal{L})$ basepoint free of finite dimension. As in §6.0, this gives a morphism

$$\phi_{\mathcal{L}, W} : X \longrightarrow \mathbb{P}(W^{\vee}).$$

Let $\mathcal{E} = W \otimes_{\mathbb{C}} \mathcal{O}_X$. The corresponding vector bundle is $V_{\mathcal{E}} = X \times W$, so

$$(7.0.4) \quad \mathbb{P}(\mathcal{E}) = \mathbb{P}(V_{\mathcal{E}}^{\vee}) = X \times \mathbb{P}(W^{\vee}).$$

By Proposition 6.0.24, the natural map $\mathcal{E} \rightarrow \mathcal{L}$ is surjective since W has no base-points. By Lemma 7.0.8, we get an injection of projective bundles

$$\mathbb{P}(\mathcal{L}) \longrightarrow \mathbb{P}(\mathcal{E}).$$

The lemma also implies $\mathbb{P}(\mathcal{L}) = X$. Using this and (7.0.4), we get an injection

$$X \longrightarrow X \times \mathbb{P}(W^{\vee}).$$

Projection onto the second factor gives a morphism $X \rightarrow \mathbb{P}(W^{\vee})$, which is the morphism $\phi_{\mathcal{L}, W}$ from §6.0 (Exercise 7.0.6).

We should mention that one can define the “projective bundle” $\mathbb{P}(\mathcal{E})$ for any coherent sheaf \mathcal{E} on X . See [77, II.7].

Exercises for §7.0.

7.0.1. Prove Proposition 7.0.2.

7.0.2. Prove Proposition 7.0.4. Hint: First prove the special case given by (7.0.1). Recall from §3.4 that \mathbb{P}^n is complete, so that $\mathbb{P}^n \rightarrow \{\text{pt}\}$ is proper.

7.0.3. Complete the proof of Proposition 7.0.5.

7.0.4. Let $\alpha : X \rightarrow Y$ and $\beta : Y \rightarrow Z$ be morphisms such that $\beta \circ \alpha : X \rightarrow Z$ is proper. Prove that $\alpha : X \rightarrow Y$ is also proper. Hint: As noted in the comments following Corollary 3.4.8, being proper is equivalent to being topologically proper (Definition 3.4.2). Also, $T \subseteq Y$ implies $\alpha^{-1}(T) \subseteq (\beta \circ \alpha)^{-1}(\beta(T))$.

7.0.5. Prove Lemma 7.0.8. Hint: Work on an open cover of X where all of the bundles involved are trivial.

7.0.6. In the discussion following (7.0.4), we constructed a morphism $X \rightarrow \mathbb{P}(W^{\vee})$ using the surjection $\mathcal{E} = W \otimes_{\mathbb{C}} \mathcal{O}_X \rightarrow \mathcal{L}$. Prove that this coincides with the morphism $\phi_{\mathcal{L}, W}$.

7.0.7. Show that $\mathbb{C}^2 \setminus \{0, 0\}$ is quasiprojective but neither affine nor projective.

§7.1. Polyhedra and Toric Varieties

This section and the next will study quasiprojective toric varieties and projective toric morphisms. Our starting point is the observation that just as polytopes give projective toric varieties, polyhedra give projective toric morphisms.

Polyhedra. Recall that a polyhedron $P \subseteq M_{\mathbb{R}}$ is the intersection of finitely many closed half-spaces

$$P = \{m \in M_{\mathbb{R}} \mid \langle m, u_i \rangle \geq -a_i, i = 1, \dots, s\}.$$

A basic structure theorem tells us that P is a Minkowski sum

$$P = Q + C,$$

where Q is a polytope and C is a polyhedral cone (see [175, Thm. 1.2]). If P is presented as above, then the cone part of P is

$$(7.1.1) \quad C = \{m \in M_{\mathbb{R}} \mid \langle m, u_i \rangle \geq 0, i = 1, \dots, s\}.$$

(Exercise 7.1.1). Following [175], we call C the *recession cone* of P .

Similar to polytopes, polyhedra have supporting hyperplanes, faces, facets, vertices, edges, etc. One difference is that some polyhedra have no vertices.

Lemma 7.1.1. *Let $P \subseteq M_{\mathbb{R}}$ be a polyhedron with recession cone C .*

(a) *The set $V = \{v \in P \mid v \text{ is a vertex}\}$ is finite and is nonempty if and only if C is strongly convex.*

(b) *If C is strongly convex, then $P = \text{Conv}(V) + C$.*

Proof. You will prove this in Exercises 7.1.2–7.1.5. \square

Example 7.1.2. The polyhedron $P = \{(a_1, \dots, a_n) \in \mathbb{R}^n \mid a_i \geq 0, \sum_{i=1}^n a_i \geq 1\}$ has vertices e_1, \dots, e_n and recession cone $C = \text{Cone}(e_1, \dots, e_n)$. \diamond

Lattice Polyhedra. We now generalize the notion of lattice polytope.

Definition 7.1.3. A polyhedron $P \subseteq M_{\mathbb{R}}$ is a *lattice polyhedron* with respect to the lattice $M \subseteq M_{\mathbb{R}}$ if

- (a) The recession cone of P is a strongly convex rational polyhedral cone.
- (b) The vertices of P lie in the lattice M .

A full dimensional lattice polyhedron has a unique facet presentation

$$(7.1.2) \quad P = \{m \in M_{\mathbb{R}} \mid \langle m, u_F \rangle \geq -a_F \text{ for all facets } F\},$$

where $u_F \in N$ is a primitive inward pointing facet normal. This was defined in Chapter 2 for full dimensional lattice polytopes but applies equally well to full dimensional lattice polyhedra. Then define $C(P) \subseteq M_{\mathbb{R}} \times \mathbb{R}$ by

$$C(P) = \{(m, \lambda) \in M_{\mathbb{R}} \times \mathbb{R} \mid \langle m, u_F \rangle \geq -\lambda a_F \text{ for all } F, \lambda \geq 0\}.$$

When P is a polytope, this reduces to the cone $C(P) = \text{Cone}(P \times \{1\})$ considered in §2.2.

Example 7.1.4. The blowup of \mathbb{C}^2 at the origin is given by the fan Σ in \mathbb{R}^2 with minimal generators $u_0 = e_1 + e_2, u_1 = e_1, u_2 = e_2$ and maximal cones $\text{Cone}(u_0, u_1), \text{Cone}(u_0, u_2)$. For the divisor $D = D_0 + D_1 + D_2$, we computed in Figure 5 from Example 4.3.4 that the polyhedron P_D is a 2-dimensional lattice polyhedron whose recession cone C is the first quadrant.

Figure 1 on the next page shows the 3-dimensional cone $C(P_D)$ with P_D at height 1. Notice how the cone C of P_D appears naturally at height 0 in Figure 1. \diamond

Some of the properties suggested by Figure 1 hold in general.

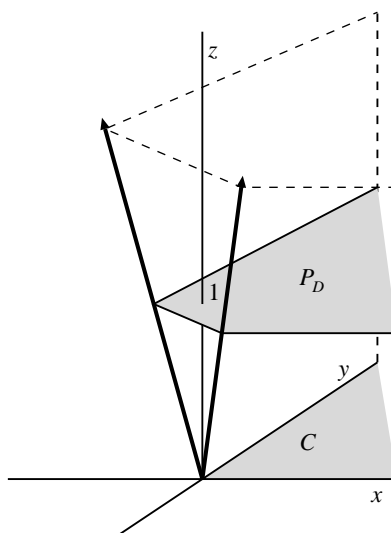

Figure 1. The cone $C(P_D)$

Lemma 7.1.5. *Let P be a full dimensional lattice polyhedron in $M_{\mathbb{R}}$ with recession cone C . Then $C(P)$ is a strongly convex cone in $M_{\mathbb{R}} \times \mathbb{R}$ and*

$$C(P) \cap (M_{\mathbb{R}} \times \{0\}) = C.$$

Proof. The final assertion of the lemma follows from (7.1.1) and the definition of $C(P)$. For strong convexity, note that $C(P) \subseteq M_{\mathbb{R}} \times \mathbb{R}_{\geq 0}$ implies

$$C(P) \cap (-C(P)) \subseteq M_{\mathbb{R}} \times \{0\}.$$

Then we are done since C is strongly convex. □

We say that a point $(m, \lambda) \in C(P)$ has *height* λ . Furthermore, when $\lambda > 0$, the “slice” of $C(P)$ at height λ is λP . If we write $P = Q + C$, where Q is a polytope, then for $\lambda > 0$,

$$\lambda P = \lambda Q + C$$

since C is a cone. It follows that as $\lambda \rightarrow 0$, the polytope shrinks to a point so that at height 0, only the cone C remains, as in Lemma 7.1.5. You can see how this works in Figure 1.

The Toric Variety of a Polyhedron. In Chapter 2, we constructed the normal fan of a full dimensional lattice polytope. We now do the same for a full dimensional lattice polyhedron P . Given a vertex $v \in P$, we get the cone

$$C_v = \text{Cone}(P \cap M - v) \subseteq M_{\mathbb{R}}.$$

Note that $v \in M$ since P is a lattice polyhedron. It follows easily that C_v is a strongly convex rational polyhedral cone of maximal dimension, so that the same is true for its dual

$$\sigma_v = C_v^\vee = \text{Cone}(P \cap M - v)^\vee \subseteq N_{\mathbb{R}}.$$

These cones fit together nicely.

Theorem 7.1.6. *Let $P \subseteq M_{\mathbb{R}}$ be a full dimensional lattice polyhedron with recession cone C . Then the cones σ_v , v a vertex of P , and their faces form a fan in $N_{\mathbb{R}}$ whose support is C^\vee .*

Proof. The proof that we get a fan is similar to the proof for the polytope case (see §2.3) and hence is omitted. To complete the proof, we need to show

$$\bigcup_{v \in V} \sigma_v = C^\vee,$$

where V is the set of vertices of P . Now take $v \in V$ and $m \in C \cap M$. Then $m = (v + m) - v \in P \cap M - v$, which easily implies $C \subseteq \text{Cone}(P \cap M - v)$. Taking duals, we obtain $\sigma_v \subseteq C^\vee$. For the opposite inclusion, take $u \in C^\vee$ and pick $v \in V$ such that $\langle v, u \rangle \leq \langle w, u \rangle$ for all $w \in V$. We show $u \in \sigma_v$ as follows. Any $m \in P \cap M$ can be written $m = \sum_{w \in V} \lambda_w w + m'$ where $\lambda_w \geq 0$, $\sum_{w \in V} \lambda_w = 1$ and $m' \in C$. Then

$$\langle m, u \rangle = \sum_{w \in V} \lambda_w \langle w, u \rangle + \langle m', u \rangle \geq \sum_{w \in V} \lambda_w \langle v, u \rangle = \langle v, u \rangle.$$

Thus $\langle m - v, u \rangle \geq 0$ for all $m - v \in P \cap M - v$, which proves $u \in \sigma_v$. \square

The fan of Theorem 7.1.6 is the *normal fan* of P , denoted Σ_P . We define X_P to be the toric variety X_{Σ_P} of the normal fan Σ_P . Here is an example.

Example 7.1.7. The polyhedron $P = \{(a_1, \dots, a_n) \in \mathbb{R}^n \mid a_i \geq 0, \sum_{i=1}^n a_i \geq 1\}$ of Example 7.1.2 has vertices e_1, \dots, e_n . The facet of P defined by $\sum_{i=1}^n a_i = 1$ has $e_1 + \dots + e_n$ as inward normal. Then the vertex e_i gives the cone

$$\sigma_{e_i} = \text{Cone}(e_1 + \dots + e_n, e_1, \dots, \widehat{e_i}, \dots, e_n).$$

These cones form the fan of the blowup of \mathbb{C}^n at the origin, so $X_P = \text{Bl}_0(\mathbb{C}^n)$. \diamond

Note that X_P is not complete in this example. In general, the normal fan has support $|\Sigma_P| = C^\vee$. We measure the deviation from completeness as follows.

The support $|\Sigma_P|$ is a rational polyhedral cone but need not be strongly convex. Recall that $W = |\Sigma_P| \cap (-|\Sigma_P|)$ is the largest subspace contained in $|\Sigma_P|$. Hence $|\Sigma_P|$ gives the following:

- The sublattice $W \cap N \subseteq N$ and the quotient lattice $N_P = N/(W \cap N)$.
- The strongly convex cone $\sigma_P = |\Sigma_P|/W \subseteq N_{\mathbb{R}}/W = (N_P)_{\mathbb{R}}$.
- The affine toric variety U_P of σ_P .

The projection map $\bar{\phi} : N \rightarrow N_P$ is compatible with the fans of X_P and U_P since $\bar{\phi}_{\mathbb{R}}(|\Sigma_P|) = \sigma_P$. Hence we get a toric morphism

$$\phi : X_P \longrightarrow U_P.$$

Since $|\Sigma_P| = \bar{\phi}_{\mathbb{R}}^{-1}(\sigma_P)$ (Exercise 7.1.6), Theorem 3.4.7 implies that ϕ is proper.

The key result of this section is that $\phi : X_P \rightarrow U_P$ is a projective morphism. From a sophisticated point of view, this is easy to see. The cone $C(P)$ gives the semigroup algebra

$$(7.1.3) \quad S_P = \mathbb{C}[C(P) \cap (M \times \mathbb{Z})],$$

where the character associated to $(m, k) \in C(P) \cap (M \times \mathbb{Z})$ is written χ^{m+tk} . This algebra is graded by height, i.e., $\deg(\chi^{m+tk}) = k$. The Proj construction in algebraic geometry associates a variety $\text{Proj}(S_P)$ to the graded ring S_P . In the appendix to this chapter, we will discuss Proj and show that

$$X_P = \text{Proj}(S_P).$$

Then standard properties of Proj easily imply that $\phi : X_P \rightarrow U_P$ is projective (see Proposition 7.A.1 in the appendix). A more elementary proof that ϕ is projective will be given in Theorem 7.1.10.

The Divisor of a Polyhedron. Let P be a full dimensional lattice polyhedron. As in the polytope case, facets of P correspond to rays in the normal fan Σ_P , so that each facet F gives a prime torus-invariant divisor $D_F \subseteq X_P$. Thus the facet presentation (7.1.2) of P gives the divisor

$$D_P = \sum_F a_F D_F,$$

where the sum is over all facets of P . Results from Chapter 4 (Proposition 4.2.10 and Example 4.3.7) easily adapt to the polyhedral case to show that D_P is Cartier (with $m_{\sigma_v} = v$ for every vertex) and the polyhedron of D_P is P , i.e., $P = P_{D_P}$. Then Proposition 4.3.3 implies that

$$(7.1.4) \quad \Gamma(X_P, \mathcal{O}_{X_P}(D_P)) = \bigoplus_{m \in P \cap M} \mathbb{C} \cdot \chi^m.$$

The definition of projective morphism given in §7.0 involves a line bundle \mathcal{L} and a finite-dimensional subspace W of global sections. The line bundle will be $\mathcal{O}_{X_P}(D_P)$ (actually a multiple kP) and W will be determined by certain carefully chosen lattice points of kP . The reason we need a multiple is that P might not have enough lattice points.

Normal and Very Ample Polyhedra. In Chapter 2, we defined normal and very ample polytopes, which are different ways of saying that there are enough lattice points. For a lattice polyhedron P , the definitions are the same.

Definition 7.1.8. Let $P \subseteq M_{\mathbb{R}}$ be a lattice polyhedron. Then:

- (a) P is **normal** if for all integers $k \geq 1$, every lattice point of kP is a sum of k lattice points of P .
- (b) P is **very ample** if for every vertex $v \in P$, the semigroup $\mathbb{N}(P \cap M - v)$ generated by $P \cap M - v$ is saturated in M .

We have the following result about normal and very ample polyhedra.

Proposition 7.1.9. Let $P \subseteq M_{\mathbb{R}}$ be a lattice polyhedron. Then:

- (a) If P is normal, then P is very ample.
- (b) If $\dim P = n \geq 2$, then kP is normal and hence very ample for all $k \geq n - 1$.

Proof. Part (a) follows from the proof of Proposition 2.2.17. For part (b), let Q be the convex hull of the vertices of P , so that $P = Q + C$, where C is the recession cone of P . It is easy to see that P is normal whenever Q is (Exercise 7.1.7). Note also that

$$kP = kQ + C.$$

Now suppose $k \geq n - 1$. If $\dim Q = 1$, then kQ and hence kP are normal. If $\dim Q \geq 2$, then kQ is normal by Theorem 2.2.11, so that kP is normal. Then kP is very ample by part (a). \square

The Projective Morphism. Let P be a full dimensional lattice polyhedron in $M_{\mathbb{R}}$, and assume that P is very ample. Then pick a finite set $\mathcal{A} \subseteq P \cap M$ with the following properties:

- \mathcal{A} contains the vertices of P .
- For every vertex $v \in P$, $\mathcal{A} - v$ generates $\text{Cone}(P \cap M - v) \cap M = \sigma_v^{\vee} \cap M$.

We can always satisfy the first condition, and the second is possible since P is very ample. Using (7.1.4), we get the subspace

$$W = \text{Span}(\chi^m \mid m \in \mathcal{A}) \subseteq \Gamma(X_P, \mathcal{O}_{X_P}(D_P)).$$

We claim that W has no basepoints since \mathcal{A} contains the vertices of P . To prove this, let v be a vertex. Recall that $D_P + \text{div}(\chi^v)$ is the divisor of zeros of the global section given by χ^v . One computes that

$$D_P + \text{div}(\chi^v) = \sum_F (a_F + \langle v, u_F \rangle) D_F.$$

Since $\langle v, u_F \rangle = -a_F$ for all facets containing v and $\langle v, u_F \rangle > -a_F$ for all other facets, the support of $D_P + \text{div}(\chi^v)$ is the complement of the affine open subset $U_{\sigma_v} \subseteq X_P$, i.e., the nonvanishing set of the section is precisely U_{σ_v} . Then we are done since the U_{σ_v} cover X_P .

It follows that we get a morphism

$$\phi_{\mathcal{L}, W} : X_P \longrightarrow \mathbb{P}(W^{\vee})$$

for $\mathcal{L} = \mathcal{O}_{X_P}(D_P)$. Here is our result.

Theorem 7.1.10. *Let P be a full dimensional lattice polyhedron. Then:*

- (a) *The toric variety X_P is quasiprojective.*
- (b) *$\phi : X_P \rightarrow U_P$ is a projective morphism.*

Proof. First suppose that P is very ample. The proof of part (a) is similar to the proof of Proposition 6.1.4. Let \mathcal{L} , W and \mathcal{A} be as above and write $\mathcal{A} = \{m_1, \dots, m_s\}$. Consider the projective toric variety

$$X_{\mathcal{A}} \subseteq \mathbb{P}^{s-1} = \mathbb{P}(W^\vee).$$

Let $I \subseteq \{1, \dots, s\}$ be the set of indices corresponding to vertices of P . So $i \in I$ gives a vertex m_i and a corresponding cone $\sigma_i = \sigma_{m_i}$ in Σ_P . Also let $U_i \subseteq \mathbb{P}^{s-1}$ be the affine open subset where the i th coordinate is nonzero. By our choice of \mathcal{A} , the proof of Proposition 6.1.4 shows that $\phi_{\mathcal{L}, W}$ induces an isomorphism

$$U_{\sigma_i} \simeq X_{\mathcal{A}} \cap U_i.$$

Since X_P is the union of the U_{σ_i} for $i \in I$, it follows that

$$(7.1.5) \quad \phi_{\mathcal{L}, W} : X_P \xrightarrow{\sim} X_{\mathcal{A}} \cap \bigcup_{i \in I} U_i.$$

Since $X_{\mathcal{A}}$ is projective, this shows that X_P is quasiprojective. Part (b) now follows immediately from Proposition 7.0.6 since $\phi : X_P \rightarrow U_P$ is proper.

When P is not very ample, we know that a positive multiple kP is. Since P and kP have the same normal fan and same recession cone, the maps $X_P \rightarrow U_P$ and $X_{kP} \rightarrow U_{kP}$ are identical. Hence the general case follows immediately from the very ample case. \square

Example 7.1.11. The polytope P from Example 7.1.7 is very ample (in fact, it is normal), and the set \mathcal{A} used in the proof of Theorem 7.1.10 can be chosen to be $\mathcal{A} = \{e_1, \dots, e_n, 2e_1, \dots, 2e_n\}$ (Exercise 7.1.8). This gives $X_{\mathcal{A}} \subseteq \mathbb{P}^{2n-1}$, where \mathbb{P}^{2n-1} has variables $x_1, \dots, x_n, w_1, \dots, w_n$ corresponding to the elements $e_1, \dots, e_n, 2e_1, \dots, 2e_n$ of \mathcal{A} . Then $X_{\mathcal{A}} \subseteq \mathbb{P}^{2n-1}$ is defined by the equations $x_i^2 w_j = x_j^2 w_i$ for $1 \leq i < j \leq n$ (Exercise 7.1.8). Since $X_P = \text{Bl}_0(\mathbb{C}^n)$ by Example 7.1.7, the isomorphism (7.1.5) implies

$$\begin{aligned} \text{Bl}_0(\mathbb{C}^n) &\simeq \{(x_1, \dots, x_n, w_1, \dots, w_n) \in \mathbb{P}^{2n-1} \mid (x_1, \dots, x_n) \neq (0, \dots, 0) \\ &\quad \text{and } x_i^2 w_j = x_j^2 w_i \text{ for } 1 \leq i < j \leq n\}. \end{aligned}$$

We get a better description of $\text{Bl}_0(\mathbb{C}^n)$ using the vertices $\mathcal{B} = \{e_1, \dots, e_n\}$ of P . This gives a map $X_P \rightarrow \mathbb{P}^{n-1}$ which, when combined with $X_P \rightarrow U_P = \mathbb{C}^n$, gives a morphism

$$\Phi : X_P \rightarrow \mathbb{P}^{n-1} \times \mathbb{C}^n.$$

Let \mathbb{P}^{n-1} and \mathbb{C}^n have variables x_1, \dots, x_n and y_1, \dots, y_n respectively. Then Φ is an embedding onto the subvariety of $\mathbb{P}^{n-1} \times \mathbb{C}^n$ defined by $x_i y_j = x_j y_i$ for $1 \leq i < j \leq n$

(Exercise 7.1.8). Hence

$$\mathrm{Bl}_0(\mathbb{C}^n) \simeq \{(x_1, \dots, x_n, y_1, \dots, y_n) \in \mathbb{P}^{n-1} \times \mathbb{C}^n \mid x_i y_j = x_j y_i, 1 \leq i < j \leq n\}.$$

This description of the blowup $\mathrm{Bl}_0(\mathbb{C}^n)$ can be found in many books on algebraic geometry and appeared earlier in this book as Exercise 3.0.8. Note also that the projective morphism of Theorem 7.1.10 is the blowdown map $\mathrm{Bl}_0(\mathbb{C}^n) \rightarrow \mathbb{C}^n$. \diamond

Here is an example to illustrate the ideas of this section.

Example 7.1.12. Consider the full dimensional lattice polyhedron $P \subseteq \mathbb{R}^2$ defined by the inequalities

$$x \leq 2, 0 \leq y \leq 2, y \geq x + 1.$$

This polyhedron has vertices $v_1 = (1, 0)$, $v_2 = (2, 1)$, $v_3 = (2, 2)$ shown in Figure 2. The left side of the figure also shows the recession cone C and the decomposition $P = Q + C$, where Q is the convex hull of the vertices.

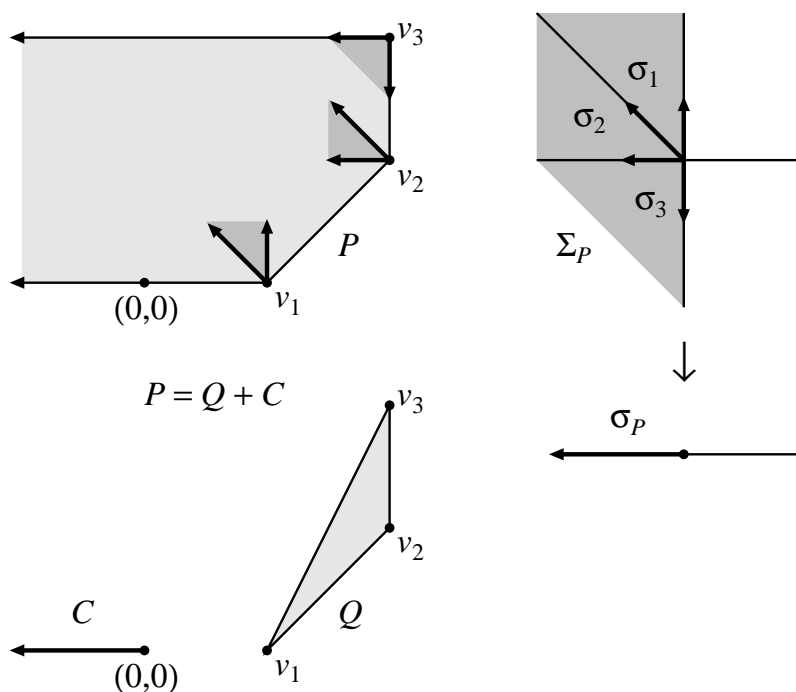

Figure 2. The polyhedron $P = Q + C$, the normal fan Σ_P , and the cone σ_P

The normal vectors at each vertex v_i are reassembled on the right to give the maximal cones σ_i of normal fan Σ_P . Note also that $|\Sigma_P|$ is not strictly convex, so we mod out by its maximal subspace to get the strictly convex cone σ_P . The projection map on the right of Figure 2 gives the projective morphism $X_P \rightarrow U_P$, where $U_P \simeq \mathbb{C}$ is the toric variety of σ_P . \diamond

Exercises for §7.1.

7.1.1. Prove (7.1.1). Hint: Fix $m_0 \in P$ and take any $m \in C$. Show that $m_0 + \lambda m \in P$ for $\lambda > 0$, so $\langle m_0 + \lambda m, u_i \rangle \geq -a_i$. Then divide by λ and let $\lambda \rightarrow \infty$.

7.1.2. Let $P = Q + C$ be a polyhedron in $M_{\mathbb{R}}$ where Q is a polytope and C is a polyhedral cone. Define $\varphi_P(u) = \min_{m \in P} \langle m, u \rangle$ for $u \in C^\vee$.

(a) Show that $\varphi_P(u) = \min_{m \in Q} \langle m, u \rangle$ for $u \in C^\vee$ and conclude that $\varphi_P : C^\vee \rightarrow \mathbb{R}$ is well-defined.

(b) Show that $\varphi_P(u) = \min_{v \in V_Q} \langle v, u \rangle$ for $u \in C^\vee$, where V_Q be the set of vertices of Q .

(c) Show that $P = \{m \in M_{\mathbb{R}} \mid \varphi_P(u) \leq \langle m, u \rangle \text{ for all } u \in C^\vee\}$. Hint: For the non-obvious direction, represent P as the intersection of closed half-spaces coming from supporting hyperplanes.

7.1.3. Let P be a polyhedron in $M_{\mathbb{R}}$ with recession cone C and let $W = C \cap (-C)$ be the largest subspace contained in C . Prove that every face of P contains a translate of W and conclude that P has no vertices when C is not strongly convex.

7.1.4. Let $P = Q + C$ be a polyhedron in $M_{\mathbb{R}}$ where Q is a polytope and C be a strongly convex polyhedral cone. Let V_Q be the set of vertices of Q . Assume that there is $v \in V_Q$ and u in the interior of C^\vee such that $\langle v, u \rangle < \langle w, u \rangle$ for all $w \neq v$ in V_Q . Prove that v is a vertex of P . Hint: Show that $H_{u,a}$, $a = \langle v, u \rangle$, is a supporting hyperplane of P such that $H_{u,a} \cap P = v$. Also show if v and u satisfy the hypothesis of the problem, then so do v and u' for any u' sufficiently close to u . Finally, Exercise 7.1.2 will be useful.

7.1.5. Let $P = Q + C$ be a polyhedron in $M_{\mathbb{R}}$ where Q is a polytope and C be a strongly convex polyhedral cone. Let V_Q be the set of vertices of Q and let

$$U_0 = \{u \in \text{Int}(C^\vee) \mid \langle v, u \rangle \neq \langle w, u \rangle \text{ whenever } v \neq w \text{ in } V_Q\}.$$

(a) Show that U_0 is open and dense in C^\vee . Hint: $\dim C^\vee = \dim N_{\mathbb{R}}$.

(b) Use Exercise 7.1.4 to show that for every $u \in U_0$, there is a vertex v of P such that $\varphi_P(u) = \langle v, u \rangle$. Conclude that the set V_P of vertices of P is nonempty and finite.

(c) Show that $\varphi_P(u) = \min_{v \in V_P} \langle v, u \rangle$ for $u \in C^\vee$.

(d) Conclude that $P = \text{Conv}(V_P) + C$. Hint: The first step is to show that $\varphi_P = \varphi_{P'}$, where $P' = \text{Conv}(V_P) + C$. Then use part (c) of Exercise 7.1.2.

7.1.6. Let $C \subseteq N_{\mathbb{R}}$ be a polyhedral cone with maximal subspace $W = C \cap (-C)$ and let $\sigma \subset N_{\mathbb{R}}/W$ be the image of C under the projection map $\gamma : N_{\mathbb{R}} \rightarrow N_{\mathbb{R}}/W$. Prove that σ is strongly convex and that $C = \gamma^{-1}(\sigma)$.

7.1.7. Let P be a lattice polytope and let Q be the convex hull of the vertices of P . Prove that if Q is normal then P is normal.

7.1.8. Prove the claims made in Example 7.1.11.

7.1.9. In this exercise, you will prove a stronger version of part (b) of Theorem 7.1.10. Let $X_{\mathcal{A}}$ and W be as in the proof of the theorem. Prove that there is a commutative diagram

$$(7.1.6) \quad \begin{array}{ccc} X_P & \xrightarrow{\phi \times \phi_{\mathcal{A}, W}} & U_P \times \mathbb{P}(W^\vee) \\ & \searrow \phi & \downarrow p_1 \\ & & U_P \end{array}$$

such that $\phi \times \phi_{\mathcal{Z}, W} : X_P \rightarrow U_P \times \mathbb{P}(W^\vee)$ is a closed embedding. Hint: See the proof of Proposition 7.0.6.

7.1.10. Let $\sigma \subseteq N_{\mathbb{R}}$ be a strongly convex rational polyhedral cone. This gives the semi-group algebra $\mathbb{C}[S_\sigma] = \mathbb{C}[\sigma^\vee \cap M]$. Given a monomial ideal $\mathfrak{a} = \langle \chi^{m_1}, \dots, \chi^{m_s} \rangle \subseteq \mathbb{C}[S_\sigma]$, we get the polyhedron

$$P = \text{Conv}(m \in M \mid \chi^m \in \mathfrak{a}),$$

Prove that $P = \text{Conv}(m_1, \dots, m_s) + \sigma^\vee$.

§7.2. Projective Morphisms and Toric Varieties

We now study when a toric morphism $X_\Sigma \rightarrow X_{\Sigma'}$ is projective.

Full Dimensional Convex Support. We first consider fans Σ in $N_{\mathbb{R}} \simeq \mathbb{R}^n$ that satisfy the following conditions:

- $|\Sigma| \subseteq N_{\mathbb{R}}$ is convex.
- $\dim |\Sigma| = n = \dim N_{\mathbb{R}}$.

We say that Σ has *convex support of full dimension*. Such fans satisfy

$$(7.2.1) \quad |\Sigma| = \text{Cone}(u_\rho \mid \rho \in \Sigma(1)) = \bigcup_{\sigma \in \Sigma(n)} \sigma$$

(Exercise 7.2.1). In particular, the maximal cones of Σ have dimension n , so we can focus on $\sigma \in \Sigma(n)$, just as in the complete case considered in §6.1.

The rational polyhedral cone $|\Sigma|$ may fail to be strongly convex. The largest subspace contained in $|\Sigma|$ is $W = |\Sigma| \cap (-|\Sigma|)$. Hence we get the following:

- The sublattice $W \cap N \subseteq N$ and the quotient lattice $N_\Sigma = N/(W \cap N)$.
- The strongly convex cone $\sigma_\Sigma = |\Sigma|/W \subseteq N_{\mathbb{R}}/W = (N_\Sigma)_{\mathbb{R}}$.
- The affine toric variety $U_\Sigma = U_{\sigma_\Sigma}$.

The projection map $\bar{\phi} : N \rightarrow N_\Sigma$ is compatible with the fans of X_Σ and U_Σ since $\bar{\phi}_{\mathbb{R}}(|\Sigma|) = \sigma_\Sigma$. This gives a toric morphism

$$(7.2.2) \quad \phi : X_\Sigma \longrightarrow U_\Sigma.$$

which as in §7.1 is easily seen to be proper. The difference between here and §7.1 is that $\phi : X_\Sigma \rightarrow U_\Sigma$ may fail to be projective. Our first goal is to understand when ϕ is projective. As you might suspect, the answer involves support functions and convexity.

The Polyhedron of a Divisor. A Weil divisor $D = \sum_\rho a_\rho D_\rho$ on X_Σ gives the polyhedron

$$P_D = \{m \in M_{\mathbb{R}} \mid \langle m, u_\rho \rangle \geq -a_\rho \text{ for all } \rho\}.$$

When Σ is complete, this is a polytope, but as we learned in §7.1, in general we have

$$P_D = Q + C,$$

where Q is a polytope and C is the recession cone of P_D .

Lemma 7.2.1. *Assume $|\Sigma|$ is convex of full dimension and let $D = \sum_{\rho} a_{\rho} D_{\rho}$ be a Weil divisor on X_{Σ} . If $P_D \neq \emptyset$, then:*

- (a) *The recession cone of P_D is $|\Sigma|^{\vee}$.*
- (b) *The set $V = \{v \in P_D \mid v \text{ is a vertex}\}$ is nonempty and finite.*
- (c) *$P_D = \text{Conv}(V) + |\Sigma|^{\vee}$.*

Proof. Combining (7.1.1) with the definition of P_D , we see that the recession cone of P_D is

$$\{m \in M_{\mathbb{R}} \mid \langle m, u_{\rho} \rangle \geq 0 \text{ for all } \rho\} = |\Sigma|^{\vee}$$

since $|\Sigma| = \text{Cone}(u_{\rho} \mid \rho \in \Sigma(1))$ by (7.2.1). This proves part (a). The recession cone is strongly convex since $|\Sigma|$ has full dimension, so that parts (b) and (c) follow from Lemma 7.1.1. \square

Divisors and Convexity. The definition of convex function given in §6.1 applies to any convex domain in $N_{\mathbb{R}}$. Thus, when $|\Sigma|$ is convex, we know what it means for the support function of a Cartier divisor to be convex. The convexity results of §6.1 adapt nicely to fans with full dimensional convex support.

Theorem 7.2.2. *Assume $|\Sigma|$ is convex of full dimension n and let φ_D be the support function of a Cartier divisor D on X_{Σ} . Then the following are equivalent:*

- (a) *D is basepoint free.*
- (b) *$m_{\sigma} \in P_D$ for all $\sigma \in \Sigma(n)$.*
- (c) *$P_D = \text{Conv}(m_{\sigma} \mid \sigma \in \Sigma(n)) + |\Sigma|^{\vee}$.*
- (d) *$\{m_{\sigma} \mid \sigma \in \Sigma(n)\}$ is the set of vertices of P_D .*
- (e) *$\varphi_D(u) = \min_{m \in P_D} \langle m, u \rangle$ for all $u \in |\Sigma|$.*
- (f) *$\varphi_D(u) = \min_{\sigma \in \Sigma(n)} \langle m_{\sigma}, u \rangle$ for all $u \in |\Sigma|$.*
- (g) *$\varphi_D : |\Sigma| \rightarrow \mathbb{R}$ is convex.*

Proof. This theorem generalizes Theorem 6.1.10. We begin by noting that Proposition 6.1.2 and Lemma 6.1.8 remain valid when $|\Sigma|$ is convex of full dimension. Since Lemma 6.1.9 applies to arbitrary fans, the equivalences (a) \Leftrightarrow (b) \Leftrightarrow (e) \Leftrightarrow (f) \Leftrightarrow (g) follow as in the proof of Theorem 6.1.10. The implication (d) \Rightarrow (c) follows from Lemma 7.2.1, and (c) \Rightarrow (b) is obvious. Finally, (b) \Rightarrow (d) follows by the argument given the proof of Theorem 6.1.10. \square

As a corollary, we see that P_D is a lattice polyhedron when D is a basepoint free Cartier divisor.

Strict Convexity. Our next task is to show that $\phi : X_\Sigma \rightarrow U_\Sigma$ is projective if and only if X_Σ has a Cartier divisor with strictly convex support function. We continue to assume that Σ has full dimensional convex support. As in §7.1, a support function φ_D is strictly convex if it is convex and for each $\sigma \in \Sigma(n)$, the equation $\varphi_D(u) = \langle m_\sigma, u \rangle$ holds only on σ . One can check that Lemma 6.1.13 remains valid in this situation.

Suppose that $D = \sum_\rho a_\rho D_\rho$ has a strictly convex support function. Then Theorem 7.2.2 and Lemma 6.1.13 imply that the m_σ , $\sigma \in \Sigma(n)$, are distinct and give the vertices of the polyhedron P_D . This polyhedron has an especially nice relation to the fan Σ .

Proposition 7.2.3. *Assume that $|\Sigma|$ is convex of full dimension and $D = \sum_\rho a_\rho D_\rho$ has a strictly convex support function. Then:*

- (a) P_D is a full dimensional lattice polyhedron.
- (b) Σ is the normal fan of P_D .

Proof. As in §7.1, a vertex $m_\sigma \in P_D$ gives the cone $C_{m_\sigma} = \text{Cone}(P_D \cap M - m_\sigma)$. We claim that

$$\sigma = C_{m_\sigma}^\vee.$$

This easily implies that P_D has full dimension and that Σ is the normal fan of P_D .

Fix $\sigma \in \Sigma(n)$ and let $\rho \in \sigma(1)$. Then $m \in P_D \cap M$ implies

$$(7.2.3) \quad \langle m, u_\rho \rangle \geq \varphi_D(u_\rho) = \langle m_\sigma, u_\rho \rangle,$$

where the inequality holds by Lemma 6.1.9 and the equality holds since $u_\rho \in \sigma$. Thus $\langle m - m_\sigma, u_\rho \rangle \geq 0$ for all $m \in P_D \cap M$, so that $u_\rho \in C_{m_\sigma}^\vee$ for all $\rho \in \sigma(1)$. Hence

$$\sigma \subseteq C_{m_\sigma}^\vee.$$

Since $|\Sigma|^\vee$ is the recession cone of P_D , the proof of Theorem 7.1.6 implies

$$C_{m_\sigma}^\vee \subseteq |\Sigma|^\vee = \bigcup_{\sigma \in \Sigma(n)} \sigma.$$

Now take $u \in \text{Int}(C_{m_\sigma}^\vee)$. Hence $u \in \sigma'$ for some $\sigma' \in \Sigma(n)$. Then $u \in C_{m_\sigma}^\vee$ and $m_{\sigma'} - m_\sigma \in C_{m_\sigma}$ imply

$$\langle m_{\sigma'} - m_\sigma, u \rangle \geq 0, \text{ so } \langle m_{\sigma'}, u \rangle \geq \langle m_\sigma, u \rangle.$$

On the other hand, if we apply (7.2.3) to the cone σ' and $m = m_\sigma$, we obtain $\langle m_\sigma, u_\rho \rangle \geq \langle m_{\sigma'}, u_\rho \rangle$. We conclude that

$$\langle m_\sigma, u \rangle = \langle m_{\sigma'}, u \rangle,$$

and the same equality holds for all elements of $\text{Int}(C_{m_\sigma}^\vee) \cap \sigma'$. This easily implies that $m_\sigma = m_{\sigma'}$. Then $\sigma = \sigma'$ by strict convexity, so that $u \in \sigma$. \square

Here is the first major result of this section.

Theorem 7.2.4. *Let $\phi : X_\Sigma \rightarrow U_\sigma$ be the proper toric morphism where U_σ is affine. Then $|\Sigma|$ is convex. Furthermore, the following are equivalent:*

- (a) X_Σ is quasiprojective.
- (b) ϕ is a projective morphism.
- (c) X_Σ has a torus-invariant Cartier divisor with strictly convex support function.

Proof. Since ϕ is proper, Theorem 3.4.7 implies that $|\Sigma| = \overline{\phi_{\mathbb{R}}^{-1}(\sigma)}$. Thus $|\Sigma|$ is convex. To prove (a) \Leftrightarrow (b) \Leftrightarrow (c), first assume that $|\Sigma|$ has full dimension.

If (c) is true, then Σ is the normal fan of the full dimensional lattice polyhedron P_D by Proposition 7.2.3. It follows that $X_\Sigma = X_{P_D}$, which is quasiprojective by Theorem 7.1.10, proving (a). Furthermore, (a) \Rightarrow (b) by Proposition 7.0.6.

If (b) is true, we will use the theory of ampleness developed in [73]. The essential facts we need are summarized in the appendix to this chapter. Since ϕ is projective, there is a line bundle \mathcal{L} on X_Σ that satisfies Definition 7.0.3. Then, since U_σ is affine, Theorem 7.A.5 and Proposition 7.A.7 imply that

- $\mathcal{L}^{\otimes k} = \mathcal{L} \otimes_{\mathcal{O}_{X_\Sigma}} \cdots \otimes_{\mathcal{O}_{X_\Sigma}} \mathcal{L}$ (k times) is generated by global sections for some integer $k > 0$.
- The nonvanishing set of a global section of \mathcal{L} is an affine open subset of X_Σ .

We know from §7.0 that $\mathcal{L} \simeq \mathcal{O}_{X_\Sigma}(D)$ for some Cartier divisor on X , and since linearly equivalent Cartier divisors give isomorphic line bundles, we may assume that D is torus-invariant (this follows from Theorem 4.2.1). Then $\mathcal{O}_{X_\Sigma}(kD)$ is generated by global sections for some $k > 0$. This implies that $\varphi_{kD} = k\varphi_D$ is convex by Theorem 7.2.2, so that φ_D is convex as well. We will show that φ_D is strictly convex by contradiction.

If strict convexity fails, then Lemma 6.1.13 implies that there is a wall $\tau = \sigma \cap \sigma'$ in Σ with $m_\sigma = m'_{\sigma'}$. Then $m = m_\sigma = m'_{\sigma'}$ corresponds to a global section s , which by the proof of Proposition 6.1.2 is nonvanishing on U_σ (since $m = m_\sigma$) and on $U_{\sigma'}$ (since $m = m_{\sigma'}$). Thus the nonvanishing set contains $U_\sigma \cup U_{\sigma'}$, which contains the complete curve $V(\tau) \subseteq U_\sigma \cup U_{\sigma'}$. But being affine, the nonvanishing set cannot contain a complete curve (Exercise 7.2.2). This completes the proof of the theorem when $|\Sigma|$ has full dimension.

It remains to consider what happens when $|\Sigma|$ fails to have full dimension. Let $N_1 = \text{Span}(|\Sigma|) \cap N$ and pick $N_0 \subseteq N$ such that $N = N_0 \oplus N_1$. The cones of Σ lie in $(N_1)_{\mathbb{R}}$ and hence give a fan Σ_1 in $(N_1)_{\mathbb{R}}$. If N_0 has rank r , then Proposition 3.3.11 implies that

$$(7.2.4) \quad X_\Sigma \simeq (\mathbb{C}^*)^r \times X_{\Sigma_1}.$$

It follows that $\varphi_D : |\Sigma| = |\Sigma_1| \rightarrow \mathbb{R}$ is the support function of a Cartier divisor D_1 on X_{Σ_1} . Note also that $|\Sigma_1|$ is convex of full dimension in $(N_1)_{\mathbb{R}}$. Since $(\mathbb{C}^*)^r$ is

quasiprojective, this allows us to reduce to the case of full dimensional support. You will supply the omitted details in Exercise 7.2.3. \square

***f*-Ample and *f*-Very Ample Divisors.** The definitions of ample and very ample from §6.1 generalize to the relative setting as follows. Recall from Definition 7.0.3 that a morphism $f : X \rightarrow Y$ is projective with respect to the line bundle \mathcal{L} when for a suitable open cover $\{U_i\}$ of Y , we can find global sections s_0, \dots, s_{k_i} of \mathcal{L} over $f^{-1}(U_i)$ that give a closed embedding

$$f^{-1}(U_i) \longrightarrow U_i \times \mathbb{P}^{k_i}.$$

Then we have the following definition.

Definition 7.2.5. Suppose that D is a Cartier divisor on a normal variety X and $f : X \rightarrow Y$ is a proper morphism.

- The divisor D and the line bundle $\mathcal{O}_X(D)$ are ***f*-very ample** if f is projective with respect to the line bundle $\mathcal{L} = \mathcal{O}_X(D)$.
- D and $\mathcal{O}_X(D)$ are ***f*-ample** when kD is *f*-very ample for some integer $k > 0$.

Hence $f : X \rightarrow Y$ is projective if and only if X has an *f*-ample line bundle.

Theorem 7.2.6. Let $\phi : X_\Sigma \rightarrow U_\sigma$ be a proper toric morphism where U_σ is affine, and let $D = \sum_\rho a_\rho D_\rho$ be a Cartier divisor on X_Σ . Then:

- D is ϕ -ample if and only if φ_D is strictly convex.
- If $\dim X_\Sigma = n \geq 2$ and D is ϕ -ample, then kD is ϕ -very ample for all $k \geq n - 1$.

Proof. This follows from Proposition 7.1.9 and Theorem 7.2.4. \square

Here is an example to illustrate

Example 7.2.7. Consider the blowdown morphism $\phi : \text{Bl}_0(\mathbb{C}^n) \rightarrow \mathbb{C}^n$. The fan for $\text{Bl}_0(\mathbb{C}^n)$ has minimal generators $u_0 = e_1 + \dots + e_n$ and $u_i = e_i$ for $1 \leq i \leq n$. Let D_0 be the divisor corresponding to u_0 . The support function φ_{-D_0} of $-D_0$ is easily seen to be strictly convex (Exercise 7.2.4). Thus:

- $-D_0$ is ϕ -ample by Theorem 7.2.6.
- ϕ is projective by Theorem 7.2.4.

Note also that the polyhedron P_{-D_0} is the polyhedron P from Example 7.1.7. \diamond

Projective Toric Morphisms. Suppose we have fans Σ in $N_{\mathbb{R}}$ and Σ' in $N'_{\mathbb{R}}$. Recall from §3.3 that a toric morphism

$$\phi : X_\Sigma \rightarrow X_{\Sigma'}$$

is induced from a map of lattices

$$\bar{\phi} : N \rightarrow N'$$

compatible with Σ and Σ' , i.e., for each $\sigma \in \Sigma$ there is $\sigma' \in \Sigma'$ with $\bar{\phi}_{\mathbb{R}}(\sigma) \subseteq \sigma'$.

We first determine when a torus-invariant Cartier divisor on X_Σ is ϕ -ample. Since projective morphisms are proper, we can assume that ϕ is proper, which by Theorem 3.4.7 is equivalent to

$$(7.2.5) \quad |\Sigma| = \overline{\phi}_{\mathbb{R}}^{-1}(|\Sigma'|).$$

Here is our result.

Theorem 7.2.8. *Let $\phi : X_\Sigma \rightarrow X_{\Sigma'}$ be a proper toric morphism and let $D = \sum_{\rho} a_{\rho} D_{\rho}$ be a Cartier divisor on X_Σ .*

- (a) *D is ϕ -ample if and only if for every $\sigma' \in \Sigma'$, φ_D is strictly convex on $\overline{\phi}_{\mathbb{R}}^{-1}(\sigma')$.*
- (b) *If $\dim X_\Sigma = n \geq 2$ and D is ϕ -ample, then kD is ϕ -very ample for all $k \geq n - 1$.*

Proof. The idea is to study what happens over the affine open subsets $U_{\sigma'} \subseteq X_{\Sigma'}$ for $\sigma' \in \Sigma'$. Observe that $\phi^{-1}(U_{\sigma'})$ is the toric variety corresponding to the fan

$$\Sigma_{\sigma'} = \{\sigma \in \Sigma \mid \overline{\phi}_{\mathbb{R}}(\sigma) \subseteq \sigma'\}.$$

Thus $\phi^{-1}(U_{\sigma'}) = X_{\Sigma_{\sigma'}}$. Let $\phi_{\sigma'} = \phi|_{\phi^{-1}(U_{\sigma'})}$ and consider the diagram

$$\begin{array}{ccc} X_\Sigma & \xrightarrow{\phi} & X_{\Sigma'} \\ \uparrow & & \uparrow \\ \phi^{-1}(U_{\sigma'}) & \xrightarrow{\phi_{\sigma'}} & U_{\sigma'} \\ \parallel & & \parallel \\ X_{\Sigma_{\sigma'}} & \xrightarrow{\phi_{\sigma'}} & U_{\sigma'}. \end{array}$$

Also let $D_{\sigma'}$ be the restriction of D to $\phi^{-1}(U_{\sigma'}) = X_{\Sigma_{\sigma'}}$.

By Proposition 7.A.6, D is ϕ -ample if and only if the restriction $D|_{\phi^{-1}(U_{\sigma'})}$ is $\phi|_{\phi^{-1}(U_{\sigma'})}$ -ample for all $\sigma' \in \Sigma'$. Using the above notation, this becomes

$$D \text{ is } \phi\text{-ample} \iff D_{\sigma'} \text{ is } \phi_{\sigma'}\text{-ample for all } \sigma' \in \Sigma'.$$

However, Theorem 7.2.6 implies that

$$D_{\sigma'} \text{ is } \phi_{\sigma'}\text{-ample} \iff \varphi_{D_{\sigma'}} \text{ is strictly convex.}$$

This completes the proof of the theorem. □

It is now easy to characterize when a toric morphism is projective.

Theorem 7.2.9. *Let $\phi : X_\Sigma \rightarrow X_{\Sigma'}$ be a toric morphism. Then the following are equivalent:*

- (a) *ϕ is projective.*
- (b) *ϕ is proper and X_Σ has a torus-invariant Cartier divisor D whose support function φ_D is strictly convex on $\overline{\phi}_{\mathbb{R}}^{-1}(\sigma')$ for all $\sigma' \in \Sigma'$.* □

You will prove Theorem 7.2.9 in Exercise 7.2.5. The first proof of this theorem was given in [103, Thm. 13 of Ch. I]. In Chapter 11 we will use this result to construct interesting examples of projective toric morphisms.

Exercises for §7.2.

7.2.1. Prove (7.2.1).

7.2.2. Prove that an affine variety cannot contain a complete variety of positive dimension. Hint: If X is complete and irreducible, then $\Gamma(X, \mathcal{O}_X) = \mathbb{C}$.

7.2.3. This exercise will complete the proof of Theorem 7.2.4. Let $\phi : X_\Sigma \rightarrow U_\sigma$ satisfy the hypothesis of the theorem and write X_Σ as in (7.2.4). We also have the Cartier divisors D on X_Σ and D_1 on X_{Σ_1} as in the proof of the theorem.

- (a) Assume that ϕ is projective. Prove that X_Σ is quasiprojective and conclude that X_{Σ_1} is quasiprojective. Now use the first part of the proof to show that φ_D is strictly convex. Hint: See Exercise 7.0.1.
- (b) Assume that φ_D is strictly convex. Prove that X_{Σ_1} is quasiprojective and conclude that X_Σ is quasiprojective. Then use Proposition 7.0.6.

7.2.4. Prove that the support function φ_{-D_0} in Example 7.2.7 is strictly convex. We will generalize this result considerably in Chapter 11.

7.2.5. Prove Theorem 7.2.9.

§7.3. Projective Bundles and Toric Varieties

Given a vector bundle or projective bundle over a toric variety, the nicest case is when the bundle is also a toric variety. This will lead to some lovely examples of toric varieties.

Toric Vector Bundles and Cartier Divisors. A Cartier divisor $D = \sum_\rho a_\rho D_\rho$ on a toric variety X_Σ gives the line bundle $\mathcal{L} = \mathcal{O}_{X_\Sigma}(D)$, which is the sheaf of sections of the rank 1 vector bundle $\pi : V_{\mathcal{L}} \rightarrow X_\Sigma$.

We will show that $V_{\mathcal{L}}$ is a toric variety and π is a toric morphism by constructing the fan of $V_{\mathcal{L}}$ in terms of Σ and D . To motivate our construction, recall that for $m \in M$, we have

$$\begin{aligned} \chi^m \in \Gamma(X_\Sigma, \mathcal{O}_{X_\Sigma}(D)) &\iff m \in P_D \\ &\iff \langle m, u \rangle \geq \varphi_D(u) \text{ for all } u \in |\Sigma| \\ &\iff \text{the graph of } u \mapsto \langle m, u \rangle \text{ lies} \\ &\quad \text{above the graph of } \varphi_D. \end{aligned}$$

The first equivalence follows from Proposition 4.3.3 and the second from Proposition 6.1.9. The key word is “above”: it tells us to focus on the part of $N_{\mathbb{R}} \times \mathbb{R}$ that lies above the graph of φ_D .

We define the fan $\Sigma \times D$ in $N_{\mathbb{R}} \times \mathbb{R}$ as follows. Given $\sigma \in \Sigma$, set

$$\begin{aligned} \tilde{\sigma} &= \{(u, \lambda) \mid u \in \sigma, \lambda \geq \varphi_D(u)\} \\ &= \text{Cone}((0, 1), (u_\rho, -a_\rho) \mid \rho \in \sigma(1)), \end{aligned}$$

where the second equality follows since $\varphi_D(u_\rho) = -a_\rho$ and φ_D is linear on σ . Note that $\tilde{\sigma}$ is a strongly convex rational polyhedral cone in $N_{\mathbb{R}} \times \mathbb{R}$. Then let $\Sigma \times D$ be the set consisting of the cones $\tilde{\sigma}$ for $\sigma \in \Sigma$ and their faces. This is a fan in $N_{\mathbb{R}} \times \mathbb{R}$, and the projection $\bar{\pi} : N \times \mathbb{Z} \rightarrow N$ is clearly compatible with $\Sigma \times D$ and Σ . Hence we get a toric morphism

$$\pi : X_{\Sigma \times D} \longrightarrow X_{\Sigma}.$$

Proposition 7.3.1. $\pi : X_{\Sigma \times D} \rightarrow X_{\Sigma}$ is a rank 1 vector bundle whose sheaf of sections is $\mathcal{O}_{X_{\Sigma}}(D)$.

Proof. We first show that π is a toric fibration as in Theorem 3.3.19. The kernel of $\bar{\pi} : N \times \mathbb{Z} \rightarrow N$ is $N_0 = \{0\} \times \mathbb{Z}$, and the fan $\Sigma_0 = \{\sigma \in \Sigma \times D \mid \sigma \subseteq (N_0)_{\mathbb{R}}\}$ has $\sigma_0 = \text{Cone}((0, 1))$ as its unique maximal cone. Also, for $\sigma \in \Sigma$ let

$$\hat{\sigma} = \text{Cone}((u_\rho, -a_\rho) \mid \rho \in \sigma(1)).$$

This is the face of $\tilde{\sigma}$ consisting of points (u, λ) where $\varphi_D(u) = \lambda$. Thus $\hat{\sigma} \in \Sigma \times D$ and in fact $\hat{\Sigma} = \{\hat{\sigma} \mid \sigma \in \Sigma\}$ is a subfan of $\Sigma \times D$. Since $\tilde{\sigma} = \hat{\sigma} + \sigma_0$ and $\bar{\pi}_{\mathbb{R}}$ maps $\hat{\sigma}$ bijectively to σ , we see that $\Sigma \times D$ is split by Σ and Σ_0 in the sense of Definition 3.3.18. Since $X_{\Sigma_0, N_0} = \mathbb{C}$, Theorem 3.3.19 implies that

$$\pi^{-1}(U_{\sigma}) \simeq U_{\sigma} \times \mathbb{C}.$$

To see that this gives the desired vector bundle, we study the transition functions. First note that $\pi^{-1}(U_{\sigma}) = U_{\tilde{\sigma}}$, so that the above isomorphism is

$$U_{\tilde{\sigma}} \simeq U_{\sigma} \times \mathbb{C},$$

which by projection induces a map $U_{\tilde{\sigma}} \rightarrow \mathbb{C}$. It is easy to check that this map is $\chi^{(-m_{\sigma}, 1)}$, where $\varphi_D(u) = \langle m_{\sigma}, u \rangle$ for $u \in \sigma$ (Exercise 7.3.1). Note that

$$(-m_{\sigma}, 1) \in \tilde{\sigma}^{\vee} \cap (M \times \mathbb{Z}),$$

follows directly from the definition of $\tilde{\sigma}$. Then, given another cone $\tau \in \Sigma$, the transition map from $U_{\sigma \cap \tau} \times \mathbb{C} \subseteq U_{\tau} \times \mathbb{C}$ to $U_{\sigma \cap \tau} \times \mathbb{C} \subseteq U_{\sigma} \times \mathbb{C}$ is given by $(u, t) \mapsto (u, g_{\sigma\tau}(u)t)$, where $g_{\sigma\tau} = \chi^{m_{\tau} - m_{\sigma}}$ (Exercise 7.3.1).

We are now done, since the proof of Proposition 6.1.20 shows that $\mathcal{O}_{X_{\Sigma}}(D)$ is the sheaf of sections of a rank 1 vector bundle over X_{Σ} whose transition functions are $g_{\sigma\tau} = \chi^{m_{\tau} - m_{\sigma}}$. \square

This construction is easy but leads to some surprising rich examples.

Example 7.3.2. Consider \mathbb{P}^n with its usual fan and let D_0 correspond to the minimal generator $u_0 = -e_1 - \cdots - e_n$. Recall that $\mathcal{O}_{\mathbb{P}^n}(-D_0)$ is denoted $\mathcal{O}_{\mathbb{P}^n}(-1)$. This gives the rank 1 vector bundle $V \rightarrow \mathbb{P}^n$ described in Proposition 7.3.1 whose fan Σ in $\mathbb{R}^n \times \mathbb{R} = \mathbb{R}^{n+1}$ has minimal generators

$$e_1, \dots, e_{n+1}, -e_1 - \cdots - e_n + e_{n+1}.$$

You will check this in Exercise 7.3.2.

We can also describe this vector bundle geometrically as follows. Consider the lattice polyhedron in \mathbb{R}^{n+1} given by

$$P = \text{Conv}(0, e_1, \dots, e_n) + \text{Cone}(e_{n+1}, e_1 + e_{n+1}, \dots, e_n + e_{n+1}).$$

The normal fan of P is the fan Σ (Exercise 7.3.2), so that X_P is the above vector bundle V . Note also that $|\Sigma|$ is dual to the recession cone of P .

It is easy to see that $|\Sigma|$ is a smooth cone of dimension $n + 1$, so that the projective toric morphism $X_P \rightarrow U_P$ constructed in §7.1 becomes $X_P \rightarrow \mathbb{C}^{n+1}$. When combined with the vector bundle map $X_P = V \rightarrow \mathbb{P}^n$, we get a morphism

$$X_P \longrightarrow \mathbb{P}^n \times \mathbb{C}^{n+1}.$$

When the coordinates of \mathbb{P}^n and \mathbb{C}^{n+1} are ordered correctly, the image is precisely the variety defined by $x_i y_j = x_j y_i$ (Exercise 7.3.2). In this way, we recover the description of $V \rightarrow \mathbb{P}^n$ given in Example 6.0.19. \diamond

Proposition 7.3.1 extends easily to decomposable toric vector bundles. Suppose we have r Cartier divisors $D_i = \sum_{\rho} a_{i\rho} D_{\rho}$, $i = 1, \dots, r$. This gives the locally free sheaf

$$(7.3.1) \quad \mathcal{O}_{X_{\Sigma}}(D_1) \oplus \cdots \oplus \mathcal{O}_{X_{\Sigma}}(D_r)$$

of rank r . To construct the fan of the corresponding vector bundle, we work in $N_{\mathbb{R}} \times \mathbb{R}^r$. Let e_1, \dots, e_r be the standard basis of \mathbb{R}^r and write elements of $N_{\mathbb{R}} \times \mathbb{R}^r$ as $u + \lambda_1 e_1 + \cdots + \lambda_r e_r$. Then, given $\sigma \in \Sigma$, we get the cone

$$\begin{aligned} \tilde{\sigma} &= \{u + \lambda_1 e_1 + \cdots + \lambda_r e_r \mid u \in \sigma, \lambda_i \geq \varphi_{D_i}(u) \text{ for } i = 1, \dots, r\} \\ &= \text{Cone}(u_{\rho} - a_{1\rho} e_1 - \cdots - a_{r\rho} e_r \mid \rho \in \sigma(1)) + \text{Cone}(e_1, \dots, e_r). \end{aligned}$$

One can show without difficulty that the set consisting of the cones $\tilde{\sigma}$ for $\sigma \in \Sigma$ and their faces is a fan in $N_{\mathbb{R}} \times \mathbb{R}^r$ such that the toric variety of this fan is the vector bundle over X_{Σ} whose sheaf of sections is (7.3.1) (Exercise 7.3.3).

Besides decomposable vector bundles, one can also define a *toric vector bundle* $\pi : V \rightarrow X_{\Sigma}$. Here, rather than assume that V is a toric variety, one makes the weaker assumption the torus of X_{Σ} acts on V such that the action is linear on the fibers and π is equivariant. Toric vector bundles have been classified by Klyachko [106] and others—see [138] for the historical background. Oda noted in [135, p. 41] that if a toric vector bundle is a toric variety in its own right, then the bundle is a direct sum of line bundles, as above. This can be proved using Klyachko's results.

Toric Projective Bundles. The decomposable toric vector bundles have associated toric projective bundles. Cartier divisors D_0, \dots, D_r give the locally free sheaf

$$\mathcal{E} = \mathcal{O}_{X_\Sigma}(D_0) \oplus \cdots \oplus \mathcal{O}_{X_\Sigma}(D_r),$$

of rank $r + 1$. Then $\mathbb{P}(\mathcal{E}) \rightarrow X_\Sigma$ is a projective bundle whose fibers look like \mathbb{P}^r .

To describe the fan of $\mathbb{P}(\mathcal{E})$, we first give a new description of the fan of \mathbb{P}^r . In \mathbb{R}^{r+1} , we use the standard basis e_0, \dots, e_r . The “first orthant” $\text{Cone}(e_0, \dots, e_r)$ has $r + 1$ facets

$$F_i = \text{Cone}(e_0, \dots, \hat{e}_i, \dots, e_r), \quad i = 0, \dots, r.$$

Now set $\bar{N} = \mathbb{Z}^{r+1}/\mathbb{Z}(e_0 + \cdots + e_r)$. Then the images \bar{e}_i of e_i sum to zero in \bar{N} and the images \bar{F}_i of F_i give the fan for \mathbb{P}^r in $\bar{N}_\mathbb{R}$.

The construction of $\mathbb{P}(\mathcal{E})$ given in §7.0 involves taking the dual vector bundle. Thus $\mathbb{P}(\mathcal{E}) = \mathbb{P}(V_\mathcal{E})$, where $V_\mathcal{E}$ is the vector bundle whose sheaf of sections is

$$\mathcal{O}_{X_\Sigma}(-D_0) \oplus \cdots \oplus \mathcal{O}_{X_\Sigma}(-D_r).$$

The fan of $V_\mathcal{E}$ is built from cones

$$\text{Cone}(u_\rho + a_{0\rho}e_0 + \cdots + a_{r\rho}e_r \mid \rho \in \sigma(1)) + \text{Cone}(e_0, \dots, e_r)$$

and their faces, as σ ranges over the cones $\sigma \in \Sigma$. To get the fan for $\mathbb{P}(\mathcal{E}) = \mathbb{P}(V_\mathcal{E})$, take $\sigma \in \Sigma$ and let F_i be a facet of $\text{Cone}(e_0, \dots, e_r)$. This gives the cone

$$\text{Cone}(u_\rho + a_{0\rho}e_0 + \cdots + a_{r\rho}e_r \mid \rho \in \sigma(1)) + F_i \subseteq N_\mathbb{R} \times \mathbb{R}^{r+1},$$

and one sees that $\sigma_i \subseteq N_\mathbb{R} \times \bar{N}_\mathbb{R}$ is the image of this cone under the projection map $N_\mathbb{R} \times \mathbb{R}^{r+1} \rightarrow N_\mathbb{R} \times \bar{N}_\mathbb{R}$.

Proposition 7.3.3. *The cones $\{\sigma_i \mid \sigma \in \Sigma, i = 0, \dots, r\}$ and their faces form a fan $\Sigma_\mathcal{E}$ in $N_\mathbb{R} \times \bar{N}_\mathbb{R}$ whose toric variety $X_\mathcal{E}$ is the projective bundle $\mathbb{P}(\mathcal{E})$.*

Proof. Consider the fan Σ_0 in $\bar{N}_\mathbb{R}$ given by the \bar{F}_i and their faces. Also, for $\sigma \in \Sigma$, let $\hat{\sigma}$ be the image of $\text{Cone}(u_\rho + a_{0\rho}e_0 + \cdots + a_{r\rho}e_r \mid \rho \in \sigma(1))$ in $N_\mathbb{R} \times \bar{N}_\mathbb{R}$. Then one easily adapts the proof of Proposition 7.3.1 to show that the toric variety $X_\mathcal{E}$ of $\Sigma_\mathcal{E}$ is a fibration over X_Σ with fiber \mathbb{P}^r . Furthermore, working over an affine open subset of X_Σ , one sees that $X_\mathcal{E}$ is obtained from $V_\mathcal{E}$ by the process described in §7.0. We leave the details as Exercise 7.3.4. \square

In practice, one usually replaces $\bar{N} = \mathbb{Z}^{r+1}/\mathbb{Z}(e_0 + \cdots + e_r)$ with \mathbb{Z}^r and the basis $\mathbf{e}_1, \dots, \mathbf{e}_r$. Then set $\mathbf{e}_0 = -\mathbf{e}_1 - \cdots - \mathbf{e}_r$ and we redefine F_i as

$$(7.3.2) \quad F_i = \text{Cone}(\mathbf{e}_0, \dots, \hat{\mathbf{e}}_i, \dots, \mathbf{e}_r) \subseteq \mathbb{R}^r$$

and for a cone $\sigma \in \Sigma$, redefine σ_i as

$$(7.3.3) \quad \sigma_i = \text{Cone}(u_\rho + (a_{1\rho} - a_{0\rho})\mathbf{e}_1 + \cdots + (a_{r\rho} - a_{0\rho})\mathbf{e}_r \mid \rho \in \sigma(1)) + F_i$$

in $N_\mathbb{R} \times \mathbb{R}^r$. This way, $\Sigma_\mathcal{E}$ is a fan in $N_\mathbb{R} \times \mathbb{R}^r$. Here is a classic example.

Example 7.3.4. The fan for \mathbb{P}^1 has minimal generators u_1 and $u_0 = -u_1$. Also let $\mathcal{O}_{\mathbb{P}^1}(1) = \mathcal{O}_{\mathbb{P}^1}(D_0)$, where D_0 be the divisor corresponding to u_0 . Fix an integer $a \geq 0$ and consider

$$\mathcal{E} = \mathcal{O}_{\mathbb{P}^1} \oplus \mathcal{O}_{\mathbb{P}^1}(a).$$

As above, we get a fan $\Sigma_{\mathcal{E}}$ in $\mathbb{R} \times \mathbb{R} = \mathbb{R}^2$. The minimal generators u_0, u_1 live in the first factor. In the second factor, the vectors $\mathbf{e}_0 = -\sum_{i=1}^r \mathbf{e}_i, \mathbf{e}_1, \dots, \mathbf{e}_r$ in the above construction reduce to $\mathbf{e}_0 = -\mathbf{e}_1, \mathbf{e}_1$. Thus $F_0 = \text{Cone}(\mathbf{e}_1)$ and $F_1 = \text{Cone}(\mathbf{e}_0)$. We will use u_1, \mathbf{e}_1 as the basis of \mathbb{R}^2 .

The maximal cones for the fan of \mathbb{P}^1 are $\sigma = \text{Cone}(u_1)$ and $\sigma' = \text{Cone}(u_0)$. Then $\Sigma_{\mathcal{E}}$ has four cones:

$$\begin{aligned} \tilde{\sigma}_0 &= \text{Cone}(u_1 + (0-0)\mathbf{e}_1) + F_0 = \text{Cone}(u_1, \mathbf{e}_1) \\ \tilde{\sigma}_1 &= \text{Cone}(u_1 + (0-0)\mathbf{e}_1) + F_1 = \text{Cone}(u_1, -\mathbf{e}_1) \\ \tilde{\sigma}'_0 &= \text{Cone}(u_0 + (a-0)\mathbf{e}_1) + F_0 = \text{Cone}(-u_1 + a\mathbf{e}_1, \mathbf{e}_1) \\ \tilde{\sigma}'_1 &= \text{Cone}(u_0 + (a-0)\mathbf{e}_1) + F_1 = \text{Cone}(-u_1 + a\mathbf{e}_1, -\mathbf{e}_1). \end{aligned}$$

This is the fan for the Hirzebruch surface \mathcal{H}_a . Thus

$$\mathcal{H}_a = \mathbb{P}(\mathcal{O}_{\mathbb{P}^1} \oplus \mathcal{O}_{\mathbb{P}^1}(a)).$$

Note also that the toric morphism $\mathcal{H}_a \rightarrow \mathbb{P}^1$ constructed earlier is the projection map for the projective bundle. \diamond

This example generalizes as follows.

Example 7.3.5. Given integers $s, r \geq 1$ and $0 \leq a_1 \leq \dots \leq a_r$, consider the projective bundle

$$\mathbb{P}(\mathcal{E}) = \mathbb{P}(\mathcal{O}_{\mathbb{P}^s} \oplus \mathcal{O}_{\mathbb{P}^s}(a_1) \oplus \dots \oplus \mathcal{O}_{\mathbb{P}^s}(a_r)).$$

The fan $\Sigma_{\mathcal{E}}$ of $\mathbb{P}(\mathcal{E})$ has a nice description. We will work in $\mathbb{R}^s \times \mathbb{R}^r$, where \mathbb{R}^s has basis u_1, \dots, u_s and \mathbb{R}^r has basis $\mathbf{e}_1, \dots, \mathbf{e}_r$. Also set $u_0 = -\sum_{j=1}^s u_j$ and $\mathbf{e}_0 = -\sum_{i=1}^s \mathbf{e}_i$. As usual, u_0 corresponds to the divisor D_0 of \mathbb{P}^s such that $\mathcal{O}_{\mathbb{P}^s}(a_i) = \mathcal{O}_{\mathbb{P}^s}(a_i D_0)$.

The description (7.3.3) of the cones in Σ uses generators of the form

$$(7.3.4) \quad u_\rho + (a_{1\rho} - a_{0\rho})\mathbf{e}_1 + \dots + (a_{r\rho} - a_{0\rho})\mathbf{e}_r,$$

where the u_ρ are minimal generators of the fan of the base of the projective bundle. Here, the u_ρ 's are u_0, \dots, u_s . Since we are using the divisors $0, a_1 D_0, \dots, a_r D_0$, the formula (7.3.4) simplifies dramatically, giving minimal generators

$$\begin{aligned} u_\rho = u_0 : \mathbf{v}_0 &= u_0 + a_1 \mathbf{e}_1 + \dots + a_r \mathbf{e}_r \\ u_\rho = u_j : \mathbf{v}_j &= u_j, \quad j = 1, \dots, s. \end{aligned}$$

Since the maximal cones of \mathbb{P}^s are $\text{Cone}(u_0, \dots, \hat{u}_j, \dots, u_s)$, (7.3.2) and (7.3.3) imply that the maximal cones of Σ are

$$\text{Cone}(\mathbf{v}_0, \dots, \hat{\mathbf{v}}_j, \dots, \mathbf{v}_s) + \text{Cone}(\mathbf{e}_0, \dots, \hat{\mathbf{e}}_i, \dots, \mathbf{e}_r)$$

for all $j = 0, \dots, s$ and $i = 0, \dots, r$. It is also easy to see that the minimal generators $\mathbf{v}_0, \dots, \mathbf{v}_s, \mathbf{e}_0, \dots, \mathbf{e}_r$ have the following properties:

- $\mathbf{v}_1, \dots, \mathbf{v}_s, \mathbf{e}_1, \dots, \mathbf{e}_r$ form a basis of $\mathbb{Z}^s \times \mathbb{Z}^r$.
- $\mathbf{e}_0 + \dots + \mathbf{e}_r = 0$.
- $\mathbf{v}_0 + \dots + \mathbf{v}_s = a_1 \mathbf{e}_1 + \dots + a_r \mathbf{e}_r$.

The first two bullets are clear, and the third follows from $\sum_{j=0}^s u_j = 0$ and the definition of the \mathbf{v}_j .

One also sees that $X_{\Sigma_{\mathcal{E}}} = \mathbb{P}(\mathcal{E})$ is smooth of dimension $s + r$. Since $\Sigma_{\mathcal{E}}$ has $(s + 1) + (r + 1) = s + r + 2$ minimal generators, the description of the Picard group given in §4.2 implies that

$$\text{Pic}(\mathbb{P}(\mathcal{E})) \simeq \mathbb{Z}^2.$$

(Exercise 7.3.5). Also observe that $\{\mathbf{v}_0, \dots, \mathbf{v}_s\}$ and $\{\mathbf{e}_0, \dots, \mathbf{e}_r\}$ give primitive collections of $\Sigma_{\mathcal{E}}$. We will see below that these are the only primitive collections of $\Sigma_{\mathcal{E}}$. Furthermore, they are extremal in the sense of §6.3 and their primitive relations generate the Mori cone of $\mathbb{P}(\mathcal{E})$.

This is a very rich example! ◇

A Classification Theorem. Kleinschmidt [105] classified all smooth projective toric varieties with Picard number 2, i.e., with $\text{Pic}(X_{\Sigma}) \simeq \mathbb{Z}^2$. The rough idea is that they are the toric projective bundles described in Example 7.3.5. Following ideas of Batyrev [6], we will use primitive collections to obtain the classification.

We begin with some results from [6] about primitive collections. Recall from §6.3 that a primitive collection $P = \{\rho_1, \dots, \rho_k\} \subseteq \Sigma(1)$ gives the primitive relation

$$(7.3.5) \quad u_{\rho_1} + \dots + u_{\rho_k} - \sum_{\rho \in \gamma(1)} c_{\rho} u_{\rho} = 0, \quad c_{\rho} \in \mathbb{Q}_{>0},$$

where $\gamma \in \Sigma$ is the minimal cone containing $u_{\rho_1} + \dots + u_{\rho_k}$. When X_{Σ} is smooth and projective, these primitive relations have some nice properties.

Proposition 7.3.6. *Let X_{Σ} be a smooth projective toric variety. Then:*

- (a) *In the primitive relation (7.3.5), $P \cap \gamma(1) = \emptyset$ and $c_{\rho} \in \mathbb{Z}_{>0}$ for all $\rho \in \sigma(1)$.*
- (b) *There is a primitive collection P with primitive relation $u_{\rho_1} + \dots + u_{\rho_k} = 0$.*

Proof. The c_{ρ} are integral since Σ is smooth. Let the minimal generators of γ be u_1, \dots, u_{ℓ} , so the primitive relation becomes

$$u_{\rho_1} + \dots + u_{\rho_k} = c_1 u_1 + \dots + c_{\ell} u_{\ell}.$$

To prove part (a), suppose for example that $u_{\rho_1} = u_1$. Then

$$u_{\rho_2} + \dots + u_{\rho_k} = (c_1 - 1)u_1 + c_2 u_2 + \dots + c_{\ell} u_{\ell}.$$

Note that $u_{\rho_2}, \dots, u_{\rho_k}$ generate a cone of Σ since P is a primitive collection. So the above equation expresses an element of a cone of Σ in terms of minimal generators

in two different ways. Since Σ is smooth, these must coincide. To see what this means, we consider two cases:

- $c_1 > 1$. Then $\{u_{\rho_2}, \dots, u_{\rho_k}\} = \{u_1, u_2, \dots, u_\ell\}$, so that $u_{\rho_i} = u_1$ for some $i > 1$. This is impossible since $u_{\rho_1} = u_1$.
- $c_1 = 1$. Then $\{u_{\rho_2}, \dots, u_{\rho_k}\} = \{u_2, \dots, u_\ell\}$. Since $u_{\rho_1} = u_1$, we obtain $P \subseteq \gamma(1)$, which is impossible since P is a primitive collection.

Since c_1 must be positive, we conclude that $u_{\rho_1} = u_1$ leads to a contradiction. From here, it is easy to see that $P \cap \gamma(1) = \emptyset$.

Turning to part (b), let φ be the support function of an ample divisor on X_Σ . Thus φ is strictly convex. Since Σ is complete, we can find an expression

$$(7.3.6) \quad b_1 u_{\rho_1} + \dots + b_s u_{\rho_s} = 0$$

such that b_1, \dots, b_s are positive integers. Note that $u_{\rho_1}, \dots, u_{\rho_s}$ cannot lie in a cone of Σ . By strict convexity and Lemma 6.1.13, it follows that

$$(7.3.7) \quad 0 = \varphi(0) = \varphi(b_1 u_{\rho_1} + \dots + b_s u_{\rho_s}) > b_1 \varphi(u_{\rho_1}) + \dots + b_s \varphi(u_{\rho_s}).$$

Pick a relation (7.3.6) so that the right-hand side is as big as possible.

The set $\{u_{\rho_1}, \dots, u_{\rho_s}\}$ is not contained in a cone of Σ and hence has a subset that is a primitive collection. By relabeling, we may assume that $\{u_{\rho_1}, \dots, u_{\rho_k}\}$, $k \leq s$, is a primitive collection. Using (7.3.6) and the primitive relation (7.3.5), we obtain the nonnegative relation

$$\sum_{\rho \in \gamma(1)} c_\rho u_\rho + \sum_{i=1}^k (b_i - 1) u_{\rho_i} + \sum_{i=k+1}^s b_i u_{\rho_i} = 0.$$

Since φ is linear on γ and strictly convex,

$$\sum_{\rho \in \gamma(1)} c_\rho \varphi(u_\rho) = \varphi\left(\sum_{\rho \in \gamma(1)} c_\rho u_\rho\right) = \varphi\left(\sum_{i=1}^k u_{\rho_i}\right) > \sum_{i=1}^k \varphi(u_{\rho_i}),$$

which implies that

$$\begin{aligned} & \sum_{\rho \in \gamma(1)} c_\rho \varphi(u_\rho) + \sum_{i=1}^k (b_i - 1) \varphi(u_{\rho_i}) + \sum_{i=k+1}^s b_i \varphi(u_{\rho_i}) \\ & > \sum_{i=1}^k \varphi(u_{\rho_i}) + \sum_{i=1}^k (b_i - 1) \varphi(u_{\rho_i}) + \sum_{i=k+1}^s b_i \varphi(u_{\rho_i}) \\ & = \sum_{i=1}^s b_i \varphi(u_{\rho_i}). \end{aligned}$$

This contradicts the maximality of the right-hand side of (7.3.7), unless $k = s$ and $b_1 = \dots = b_k = 1$, in which case we get the desired primitive collection. \square

We now prove Kleinschmidt's classification theorem.

Theorem 7.3.7. *Let X_Σ be a smooth projective toric variety with $\text{Pic}(X_\Sigma) \simeq \mathbb{Z}^2$. Then there are integers $s, r \geq 1$, $s + r = \dim X_\Sigma$ and $0 \leq a_1 \leq \dots \leq a_r$ with*

$$X_\Sigma \simeq \mathbb{P}(\mathcal{O}_{\mathbb{P}^s} \oplus \mathcal{O}_{\mathbb{P}^s}(a_1) \oplus \dots \oplus \mathcal{O}_{\mathbb{P}^s}(a_r)).$$

Proof. Let $n = \dim X_\Sigma$. Then $\text{Pic}(X_\Sigma) \simeq \mathbb{Z}^2$ and Theorem 4.2.1 imply that $\Sigma(1)$ has $n + 2$ elements. We recall two facts about divisors D on X_Σ :

- If D is nef and $\sigma \in \Sigma(n)$, then $D \sim \sum_\rho a_\rho D_\rho$ where $a_\rho = 0$ for $\rho \in \sigma(1)$ and $a_\rho \geq 0$ for $\rho \notin \sigma(1)$.
- If $D \geq 0$ and $D \sim 0$, then $D = 0$ since X_Σ is complete.

The first bullet was proved in (6.3.11), and the second is an easy consequence of Propositions 4.0.16 and 4.3.8.

By assumption, X_Σ has an ample divisor D which lies in the interior of the nef cone $\text{Nef}(X_\Sigma)$. Changing D if necessary, we can assume that D is effective and $[D] \in \text{Pic}(X_\Sigma)_\mathbb{R}$ is not a scalar multiple of any $[D_\rho]$ for $\rho \in \Sigma(1)$. The line determined by $[D]$ divides $\text{Pic}(X_\Sigma)_\mathbb{R} \simeq \mathbb{R}^2$ gives closed half-planes H^+ and H^- . Then define the sets

$$P = \{\rho \in \Sigma(1) \mid [D_\rho] \in H^+\}$$

$$Q = \{\rho \in \Sigma(1) \mid [D_\rho] \in H^-\}.$$

Note that $P \cup Q = \Sigma(1)$, and $P \cap Q = \emptyset$ by our choice of D . We claim that

$$(7.3.8) \quad \Sigma(n) = \{\sigma_{\rho, \rho'} \mid \rho \in P, \rho' \in Q\}, \text{ where}$$

$$\sigma_{\rho, \rho'} = \text{Cone}(u_{\hat{\rho}} \mid \hat{\rho} \in \Sigma(1) \setminus \{\rho, \rho'\}).$$

To prove this, first take $\sigma \in \Sigma(n)$. Since $|\sigma(1)| = n$ and $|\Sigma(1)| = n + 2$, we have

$$(7.3.9) \quad \Sigma(1) = \sigma(1) \cup \{\rho, \rho'\}.$$

Applying the first bullet above to D and σ , we get $[D] = a[D_\rho] + b[D_{\rho'}]$ where $a, b > 0$ since $[D]$ is a multiple of neither $[D_\rho]$ nor $[D_{\rho'}]$. It follows that $[D_\rho]$ and $[D_{\rho'}]$ lie on opposite sides of the line determined by $[D]$. We can relabel so that $\rho \in P$ and $\rho' \in Q$, and then σ has the desired form by (7.3.9).

For the converse, take $\rho \in P$ and $\rho' \in Q$. Since $\text{Pic}(X_\Sigma)_\mathbb{R} \simeq \mathbb{R}^2$, we can find a linear dependence

$$a_0[D_\rho] + b_0[D_{\rho'}] + c_0[D] = 0, \quad a_0, b_0, c_0 \in \mathbb{Z} \text{ not all } 0.$$

We can assume that $a_0, b_0 \geq 0$ since $[D_\rho]$ and $[D_{\rho'}]$ lie on opposite sides of the line determined by $[D]$. Note also that $c_0 < 0$ by the second bullet above, and then $a_0, b_0 > 0$ by our choice of D . It follows that $D' = a_0 D_\rho + b_0 D_{\rho'}$ is ample. In Exercise 7.3.6 you will show that

$$X_\Sigma \setminus \text{Supp}(D') = X_\Sigma \setminus (D_\rho \cup D_{\rho'})$$

is the nonvanishing set of a global section of $\mathcal{O}_{X_\Sigma}(D')$ and hence is affine. This set is also torus-invariant and hence is an affine toric variety. Thus it must be U_σ for some $\sigma \in \Sigma$. In other words,

$$X_\Sigma = U_\sigma \cup D_\rho \cup D_{\rho'}.$$

Since $U_\sigma \cap (D_\rho \cup D_{\rho'}) = \emptyset$, the Orbit-Cone correspondence (Theorem 3.2.6) implies that σ satisfies (7.3.9) and hence gives an element of $\Sigma(n)$. This completes the proof of (7.3.8).

An immediate consequence of this description of $\Sigma(n)$ is that P and Q are primitive collections. Be sure you understand why. It is also true that P and Q are the *only* primitive collections of Σ . To prove this, suppose that we had a third primitive collection R . Then $P \not\subseteq R$, so there is $\rho \in P \setminus R$, and similarly there is $\rho' \in Q \setminus R$ since $Q \not\subseteq P$. By (7.3.8), the rays of R all lie in $\sigma_{\rho, \rho'} \in \Sigma(n)$, which contradicts the definition of primitive collection.

Since X_Σ is projective and smooth, Proposition 7.3.6 guarantees that Σ has a primitive collection whose elements sum to zero. We may assume that P is this primitive collection. Let $|P| = r + 1$ and $|Q| = s + 1$, so $r, s \geq 1$ since primitive collections have at least two elements, and $r + s = n$ since $|P| + |Q| = n + 2$.

Now rename the minimal generators of the rays in P as $\mathbf{e}_0, \dots, \mathbf{e}_r$. Thus

$$\mathbf{e}_0 + \dots + \mathbf{e}_r = 0.$$

The next step is to rename the minimal generators of the rays in Q as $\mathbf{v}_0, \dots, \mathbf{v}_s$. Proposition 7.3.6 implies that $\sum_{j=0}^s \mathbf{v}_j$ lies in a cone $\gamma \in \Sigma$ whose rays lie in the complement of Q , which is P . Since P is a primitive collection, γ must omit at least one element of P , which we may assume to be the ray generated by \mathbf{e}_0 . Then the primitive relation of Q can be written

$$\mathbf{v}_0 + \dots + \mathbf{v}_s = a_1 \mathbf{e}_1 + \dots + a_r \mathbf{e}_r,$$

and by further relabeling, we may assume $0 \leq a_1 \leq \dots \leq a_r$. Finally, observe that $\mathbf{v}_1, \dots, \mathbf{v}_s, \mathbf{e}_1, \dots, \mathbf{e}_r$ generate a maximal cone of Σ by (7.3.8). Since Σ is smooth, it follows that these $r + s$ vectors form a basis of N . Comparing all of this to Example 7.3.5, we conclude that the toric variety of Σ is the projective bundle $\mathbb{P}(\mathcal{O}_{\mathbb{P}^s} \oplus \mathcal{O}_{\mathbb{P}^s}(a_1) \oplus \dots \oplus \mathcal{O}_{\mathbb{P}^s}(a_r))$. \square

The classification result proved in [105] is more general than the one given in Theorem 7.3.7. By using a result from [115] on sphere triangulations with few vertices, Kleinschmidt does not need assume that X_Σ is projective. Another proof of Theorem 7.3.7 that does not assume projective can be found in [6, Thm. 4.3]. We should also mention that our proof of (7.3.8) can be redone using the *Gale transforms* discussed in [50, II.4–6] and [175, Ch. 6].

Exercises for §7.3.

7.3.1. Here you will supply some details needed to prove Theorem 7.3.1.

- (a) In the proof we constructed a map $U_{\tilde{\sigma}} \rightarrow \mathbb{C}$. Show that this map is $\chi^{(-m_{\sigma}, 1)}$, where $\varphi_D(u) = \langle m_{\sigma}, u \rangle$ for $u \in \sigma$.
- (b) Given cones $\sigma, \tau \in \Sigma$, the transition map from $U_{\sigma \cap \tau} \times \mathbb{C} \subseteq U_{\tau} \times \mathbb{C}$ to $U_{\sigma \cap \tau} \times \mathbb{C} \subseteq U_{\sigma} \times \mathbb{C}$ is given by $(u, t) \mapsto (u, g_{\sigma\tau}(u)t)$. Prove that $g_{\sigma\tau} = \chi^{m_{\tau} - m_{\sigma}}$.

7.3.2. In Example 7.3.2, we study the rank 1 vector bundle $V \rightarrow \mathbb{P}^n$ whose sheaf of sections is $\mathcal{O}_{\mathbb{P}^n}(-1)$. Let Σ be the fan of V in \mathbb{R}^{n+1} .

- (a) Prove that $e_1, \dots, e_{n+1}, -e_1 - \dots - e_n + e_{n+1}$ are the minimal generators of Σ .
- (b) Prove that Σ is the normal fan of

$$P = \text{Conv}(0, e_1, \dots, e_n) + \text{Cone}(e_{n+1}, e_1 + e_{n+1}, \dots, e_n + e_{n+1}).$$

- (c) The example constructs a morphism $V \rightarrow \mathbb{P}^n \times \mathbb{C}^{n+1}$. Prove that the image of this map is defined by $x_i y_j = x_j y_i$ and explain how this relates to Example 6.0.19.

7.3.3. Consider the locally free sheaf (7.3.1) and the cones $\tilde{\sigma} \subseteq N_{\mathbb{R}} \times \mathbb{R}^r$ defined in the discussion following (7.3.1). Prove that these cones and their faces give a fan in $N_{\mathbb{R}} \times \mathbb{R}^r$ whose toric variety is the vector bundle with (7.3.1) as sheaf of sections.

7.3.4. Complete the proof of Proposition 7.3.3.

7.3.5. Let $\mathbb{P}(\mathcal{E}) \rightarrow \mathbb{P}^s$ be the toric projective bundle constructed in Example 7.3.5. Prove that $\text{Pic}(\mathbb{P}(\mathcal{E})) \simeq \mathbb{Z}^2$.

7.3.6. Let D be an ample effective divisor on a complete normal variety X . The goal of this exercise is to prove that $X \setminus \text{Supp}(D)$ is affine.

- (a) Assume that D is very ample. Let $s \in \Gamma(X, \mathcal{O}_X(D))$ be nonzero and consider the *nonvanishing set* of s defined by $U = \{s \in X \mid s(x) \neq 0\}$. Prove that U is affine. Hint: Since D is ample, a basis $s = s_0, s_1, \dots, s_m$ of $\Gamma(X, \mathcal{O}_X(D))$ gives the morphism $X \rightarrow \mathbb{P}^m$ described in (6.0.6), which is a closed embedding since D is very ample. Let \mathbb{P}^m have homogeneous coordinates x_0, \dots, x_m and regard X as a subset of \mathbb{P}^m . Prove that $U = X \cap U_0$, where $U_0 \subseteq \mathbb{P}^m$ is where $x_0 \neq 0$.
- (b) Explain why part (a) remains true when D is ample but not necessarily very ample. Hint: $s^k \in \Gamma(X, \mathcal{O}_X(kD))$.
- (c) Since D is effective, $1 \in \Gamma(X, \mathcal{O}_X(D))$ is a global section. Prove that the nonvanishing set of this global section is $X \setminus \text{Supp}(D)$. Hint: For $s \in \Gamma(X, \mathcal{O}_X(D))$, recall the definition of $\text{div}_0(s)$ given in §4.0.

Parts (b) and (c) imply that $X \setminus \text{Supp}(D)$ is affine when D is ample, as desired. Note also that part (b) is a special case of Proposition 7.A.7.

7.3.7. In Example 2.3.15, we defined the *rational normal scroll* $S_{a,b}$ to be the toric variety of the polygon

$$P_{a,b} = \text{Conv}(0, ae_1, e_2, be_1 + e_2) \subseteq \mathbb{R}^2,$$

where $a, b \in \mathbb{N}$ satisfy $1 \leq a \leq b$, and in Example 3.1.16, we showed that $S_{a,b} \simeq \mathcal{H}_{b-a}$, i.e., every rational normal scroll is a Hirzebruch surface. This exercise will explore an n -dimensional analog of $P_{a,b}$.

Take integers $1 \leq d_0 \leq d_1 \leq \cdots \leq d_{n-1}$. Then $P_{d_0, \dots, d_{n-1}}$ is the lattice polytope in \mathbb{R}^n having the $2n$ lattice points

$$0, d_0 e_1, e_2, e_2 + d_1 e_1, e_3, e_3 + d_2 e_1, \dots, e_n, e_n + d_{n-1} e_1$$

as vertices. The toric variety of $P_{d_0, \dots, d_{n-1}}$ is denoted $S_{d_0, \dots, d_{n-1}}$.

- Explain why $P_{d_0, \dots, d_{n-1}}$ is a “truncated prism” whose base in $\{0\} \times \mathbb{R}^{n-1}$ is the standard simplex Δ_{n-1} , and above the vertices of Δ_{n-1} there are edges of lengths d_0, \dots, d_{n-1} . Here, “above” means the e_1 direction. Draw a picture when $n = 3$.
- Prove that $S_{d_0, \dots, d_{n-1}} \simeq \mathbb{P}(\mathcal{O}_{\mathbb{P}^1}(d_0) \oplus \cdots \oplus \mathcal{O}_{\mathbb{P}^1}(d_{n-1}))$.
- $S_{d_0, \dots, d_{n-1}}$ is smooth by part (b), so that $P_{d_0, \dots, d_{n-1}}$ is very ample and hence gives a projective embedding of $S_{d_0, \dots, d_{n-1}}$. Explain how this embedding consists of n embeddings of \mathbb{P}^1 such that for each point $p \in \mathbb{P}^1$, the resulting n points in projective space are connected by an $(n-1)$ -dimensional plane that lies in $S_{d_0, \dots, d_{n-1}}$.
- Explain how part (c) relates to the scroll discussion in Example 2.3.15.
- Show that the $(n-1)$ -dimensional plane associated to $p \in \mathbb{P}^1$ in part (c) is the fiber of the projective bundle $\mathbb{P}(\mathcal{O}_{\mathbb{P}^1}(d_0) \oplus \cdots \oplus \mathcal{O}_{\mathbb{P}^1}(d_{n-1})) \rightarrow \mathbb{P}^1$.

7.3.8. Consider the toric variety $\mathbb{P}(\mathcal{E})$ constructed in Example 7.3.5.

- Prove that $\mathbb{P}(\mathcal{E})$ is projective. Hint: Proposition 7.0.5.
- Show that $\mathbb{P}(\mathcal{E}) \simeq \mathbb{P}(\mathcal{O}_{\mathbb{P}^s}(1) \oplus \mathcal{O}_{\mathbb{P}^s}(a_1 + 1) \oplus \cdots \oplus \mathcal{O}_{\mathbb{P}^s}(a_r + 1))$. Hint: Part (b) of Lemma 7.0.8.
- Find a lattice polytope in $\mathbb{R}^s \times \mathbb{R}^r$ whose toric variety is $\mathbb{P}(\mathcal{E})$. Hint: In the polytope of Exercise 7.3.7, each vertex of $\{0\} \times \Delta_{n-1} \subseteq \mathbb{R} \times \mathbb{R}^{n-1}$ is attached to a line segment in the normal direction. Also observe that a line segment is a multiple of Δ_1 . Adapt this by using $\{0\} \times \Delta_r \subseteq \mathbb{R}^s \times \mathbb{R}^r$ as “base” and then, at each vertex of Δ_r , attach a positive multiple of Δ_s in the normal direction.

7.3.9. Let X_Σ be a projective toric variety and let D_0, \dots, D_r be torus-invariant ample divisors on X_Σ . Each D_i gives a lattice polytope $P_i = D_{P_i}$ whose normal fan is Σ . Prove that the projective bundle

$$\mathbb{P}(\mathcal{O}_{X_\Sigma}(D_0) \oplus \cdots \oplus \mathcal{O}_{X_\Sigma}(D_r))$$

is the toric variety of the polytope in $N_{\mathbb{R}} \times \mathbb{R}$

$$\text{Conv}(P_0 \times \{0\} \cup P_1 \times \{e_1\} \cup \cdots \cup P_r \times \{e_r\}).$$

Hint: If you get stuck, see [31, Sec. 3]. Do you see how this relates to Exercise 7.3.8?

7.3.10. Use primitive collections to show that \mathbb{P}^n is the only smooth projective toric variety with Picard number 1.

Appendix: More on Projective Morphisms

In this appendix, we discuss some technical details related to projective morphisms.

Proj of a Graded Ring. As described in [48, III.2] and [77, II.2], a graded ring

$$S = \bigoplus_{d=0}^{\infty} S_d$$

gives the scheme $\text{Proj}(S)$ such that for every non-nilpotent $f \in S_d$, we have the affine open subset $D_+(f) \subseteq \text{Proj}(S)$ with

$$D_+(f) \simeq \text{Spec}(S_{(f)}),$$

where $S_{(f)}$ is the homogenous localization of S at f , i.e.,

$$S_{(f)} = \left\{ \frac{g}{f^d} \mid g \in S_d, d \in \mathbb{N} \right\}.$$

Furthermore, if homogeneous elements $f_1, \dots, f_s \in S$ satisfy

$$\sqrt{\langle f_1, \dots, f_s \rangle} = S_+ = \bigoplus_{d>0} S_d,$$

then the affine open subsets $D_+(f_1), \dots, D_+(f_s)$ cover $\text{Proj}(S)$. Thus we can construct $\text{Proj}(S)$ by gluing together the affine varieties $D_+(f_i)$, just as we construct \mathbb{P}^n by gluing together copies of \mathbb{C}^n .

The scheme $\text{Proj}(S)$ comes equipped with a projective morphism $\text{Proj}(S) \rightarrow \text{Spec}(S_0)$ induced by the inclusions $S_0 \subseteq S_{(f)}$ for all f . For example, if $U = \text{Spec}(R)$ is an affine variety, then we get the graded ring

$$S = R[x_0, \dots, x_n]$$

such that each x_i has degree 1. Then

$$\text{Proj}(S) = U \times \mathbb{P}^n,$$

where the map $\text{Proj}(S) \rightarrow \text{Spec}(S_0) = \text{Spec}(R) = U$ is projection onto the first factor.

Here is a toric example. Let $P \subseteq M_{\mathbb{R}}$ be a full dimensional lattice polyhedron. As in §7.1, this gives:

- The toric morphism $\phi : X_P \rightarrow U_P$.
- The cone $C(P) \subseteq M_{\mathbb{R}} \times \mathbb{R}$.

Recall from (7.1.3) that $C(P)$ gives the semigroup algebra

$$S_P = \mathbb{C}[C(P) \cap (M \times \mathbb{Z})],$$

where the character associated to $(m, k) \in C(P) \cap (M \times \mathbb{Z})$ is written $\chi^m t^k$. We use the height grading given by setting $\text{deg}(\chi^m t^k) = k$. Then

Theorem 7.A.1. $X_P \simeq \text{Proj}(S_P)$. Furthermore, if P is normal, then there is a commutative diagram

$$\begin{array}{ccc} X_P & \xrightarrow{\alpha} & U_P \times \mathbb{P}^{s-1} \\ & \searrow \phi & \downarrow p_1 \\ & & U_P \end{array}$$

such that α is a closed embedding.

Proof. We will sketch the argument and leave the details as an exercise. The slice of $C(P)$ at height 0 is the recession cone C of P . Recall that $N_P = N/(W \cap N)$, where $W \subseteq C^\vee$ is the largest subspace contained in C^\vee and that U_P is the affine toric variety of σ_P , which is the image of C^\vee in $(N_P)_\mathbb{R}$. Then the inclusion $M_P \subseteq M$ dual to $N \rightarrow N_P$ gives

$$\sigma_P^\vee = C \subseteq (M_P)_\mathbb{R} \subseteq M_\mathbb{R}.$$

It follows that $(S_P)_0$, the degree 0 part of the graded ring $S_P = \mathbb{C}[C(P) \cap (M \times \mathbb{Z})]$, is $\mathbb{C}[C \cap M] = \mathbb{C}[\sigma_P^\vee \cap M]$. This implies $\text{Spec}((S_P)_0) = U_P$, so that we get a natural map $\text{Proj}(S_P) \rightarrow U_P$.

If P is normal, one sees easily that $C(P) \cap (M \times \mathbb{Z})$ is generated by its elements of height ≤ 1 . If \mathcal{H} is a Hilbert basis of $C(P) \cap (M \times \mathbb{Z})$, then $\mathcal{H} = \mathcal{H}_0 \cup \mathcal{H}_1$, where elements of \mathcal{H}_i have height i . If we write $\mathcal{H}_1 = \{(m_1, 1), \dots, (m_s, 1)\}$, then S_P is generated as an $(S_P)_0$ -algebra by $\chi^{m_1 t}, \dots, \chi^{m_s t}$. In other words, we have a surjective homomorphism of graded rings

$$(S_P)_0[x_1, \dots, x_s] \longrightarrow S_P, \quad x_i \longmapsto \chi^{m_i t}.$$

This surjection makes $\text{Proj}(S_P)$ a closed subvariety of $\text{Proj}((S_P)_0[x_1, \dots, x_s]) = U_P \times \mathbb{P}^{s-1}$ by [77, Ex. III.3.12]. This gives the commutative diagram in the statement of the theorem, except that X_P is replaced with $\text{Proj}(S_P)$. Hence $\text{Proj}(S_P) \rightarrow U_P$ is projective.

It remains to prove $X_P \simeq \text{Proj}(S_P)$. For this, let V be the set of vertices of P . Then one can prove:

- $\sqrt{\langle \chi^{vt} \mid v \in V \rangle} = (S_P)_+ = \bigoplus_{d>0} (S_P)_d$.
- If $v \in V$, then $(S_P)_{(\chi^{vt})} = \mathbb{C}[\sigma_v^\vee \cap M]$, where $\sigma_v = \text{Cone}(P \cap M - v)^\vee$.

The first bullet implies that $\text{Proj}(S_P)$ is covered by the affine open subsets $\text{Spec}((S_P)_{(\chi^{vt})})$, and the second shows that $\text{Spec}((S_P)_{(\chi^{vt})})$ is the affine toric variety of the cone σ_v . These patch together in the correct way to give $X_P \simeq \text{Proj}(S_P)$. \square

For an arbitrary full dimensional lattice polyhedron, some positive multiple is normal. Hence Theorem 7.A.1 gives a second proof of Theorem 7.1.10.

Ampleness. A comprehensive treatment of ampleness appears in Volume II of *Éléments de géométrie algébrique* (EGA) by Grothendieck and Dieudonné [73]. The results we need from EGA are spread out over several sections. Here we collect the definitions and theorems we will use in our discussion of ampleness.¹

Definition 7.A.2. A line bundle \mathcal{L} on a variety X is **absolutely ample** if for every coherent sheaf \mathcal{F} on X , there is an integer k_0 such that $\mathcal{F} \otimes_{\mathcal{O}_X} \mathcal{L}^{\otimes k}$ is generated by global sections for all $k \geq k_0$.

By [73, (4.5.5)], this is equivalent to what EGA calls “ample” in [73, (4.5.3)]. We use the name “absolutely ample” to prevent confusion with Definition 6.1.1, where “ample” is defined for line bundles on complete normal varieties.

Here is another definition from EGA.

¹The theory developed in EGA applies to very general schemes. The varieties and morphisms appearing in this book are nicely behaved—the varieties are quasi-compact and noetherian, the morphisms are of finite type, and coherent is equivalent to quasicoherent of finite type. Hence most of the special hypotheses needed for some of the results in [73] are automatically true in our situation.

Definition 7.A.3. Let $f : X \rightarrow Y$ be a morphism. A line bundle \mathcal{L} on X is **relatively ample with respect to f** if Y has an affine open cover $\{U_i\}$ such that for every i , $\mathcal{L}|_{f^{-1}(U_i)}$ is absolutely ample on $f^{-1}(U_i)$.

This is [73, (4.6.1)]. When mapping to an affine variety, relatively ample and absolutely ample coincide. More precisely, we have the following result from [73, (4.6.6)].

Proposition 7.A.4. *Let $f : X \rightarrow Y$ be a morphism, where Y is affine, and let \mathcal{L} be a line bundle on X . Then:*

$$\mathcal{L} \text{ is relatively ample with respect to } f \iff \mathcal{L} \text{ is absolutely ample.}$$

The reader should be warned that in EGA, “relatively ample with respect to f ” and “ f -ample” are synonyms. In this text, they are slightly different, since “relatively ample with respect to f ” refers to Definition 7.A.3 while “ f -ample” refers to Definition 7.2.5. Fortunately, they coincide when the map f is proper.

Theorem 7.A.5. *Let $f : X \rightarrow Y$ be a proper morphism and \mathcal{L} a line bundle on X . Then the following are equivalent:*

- (a) \mathcal{L} is relatively ample with respect to f in the sense of Definition 7.A.3.
- (b) \mathcal{L} is f -ample in the sense of Definition 7.2.5.
- (c) There is an integer $k > 0$ such that f is projective with respect to $\mathcal{L}^{\otimes k}$ in the sense of Definition 7.0.3.

Proof. First observe that (b) and (c) are equivalent by Definition 7.2.5. Now suppose that f is projective with respect to $\mathcal{L}^{\otimes k}$. Then there is an affine open covering $\{U_i\}$ of Y such that for each i , there is a finite-dimensional subspace $W \subseteq \Gamma(U_i, \mathcal{L}^{\otimes k})$ that gives a closed embedding of $f^{-1}(U_i)$ into $U_i \times \mathbb{P}(W^\vee)$ for each i .

The locally free sheaf $\mathcal{E} = W^\vee \otimes_{\mathbb{C}} \mathcal{O}_{U_i}$ is the sheaf of sections of the trivial vector bundle $U_i \times W^\vee \rightarrow U_i$. This gives the projective bundle $\mathbb{P}(\mathcal{E}) = U_i \times \mathbb{P}(W^\vee)$, so that we have a closed embedding

$$f^{-1}(U_i) \longrightarrow \mathbb{P}(\mathcal{E}).$$

By definition [73, (4.4.2)], $\mathcal{L}^{\otimes k}|_{f^{-1}(U_i)}$ is very ample for $f|_{f^{-1}(U_i)}$. Then [73, (4.6.9)] implies that $\mathcal{L}|_{f^{-1}(U_i)}$ is relatively ample with respect to $f|_{f^{-1}(U_i)}$, and hence absolutely ample by Proposition 7.A.4. Then \mathcal{L} is relatively ample with respect to f by Definition 7.A.3.

Finally, suppose that \mathcal{L} is relatively ample with respect to f and let $\{U_i\}$ be an affine open covering of Y . Then [73, (4.6.4)] implies that $\mathcal{L}|_{f^{-1}(U_i)}$ is relatively ample with respect to $f|_{f^{-1}(U_i)}$. Using [73, (4.6.9)] again, we see that $\mathcal{L}^{\otimes k}|_{f^{-1}(U_i)}$ is very ample for $f|_{f^{-1}(U_i)}$, which by definition [73, (4.4.2)] means that $f^{-1}(U_i)$ can be embedded in $\mathbb{P}(\mathcal{E})$ for a coherent sheaf \mathcal{E} on U_i . Then the proof of [171, Thm. 5.44] shows how to find finitely many sections of $\mathcal{L}^{\otimes k}$ over $f^{-1}(U_i)$ give a suitable embedding of $f^{-1}(U_i)$ into $U_i \times \mathbb{P}(W^\vee)$. \square

In EGA [73, (5.5.2)], the definition of when a morphism $f : X \rightarrow Y$ is projective involves two equivalent conditions stated in [73, (5.5.1)]. The first condition uses the projective bundle $\mathbb{P}(\mathcal{E})$ of a coherent sheaf \mathcal{E} on Y , and the second uses $\text{Proj}(\mathcal{S})$, where \mathcal{S} is a quasicohherent graded \mathcal{O}_Y -algebra such that \mathcal{S}_1 is coherent and generates \mathcal{S} . By

[73, (5.5.3)], projective is equivalent to proper and quasiprojective, and by the definition of quasiprojective [73, (5.5.1)], this means that X has a line bundle relatively ample with respect to f . Hence Theorem 7.A.5 shows that the definition of projective morphism given in EGA is equivalent to Definition 7.0.3.

We close with two further results about projective morphisms.

Proposition 7.A.6. *Let $f : X \rightarrow Y$ be a proper morphism and \mathcal{L} a line bundle on X . Given an affine open cover $\{U_i\}$ of Y , the following are equivalent:*

- (a) \mathcal{L} is f -ample.
- (b) For every i , $\mathcal{L}|_{f^{-1}(U_i)}$ is $f|_{f^{-1}(U_i)}$ -ample.

Proof. Since f is proper, so is $f|_{f^{-1}(U_i)} : f^{-1}(U_i) \rightarrow U_i$ by the universal property of properness. But for a proper morphism g , being g -ample is equivalent to being relatively ample with respect to g . Then we are done by [73, (4.6.4)]. \square

Proposition 7.A.7. *Let $f : X \rightarrow Y$ be a projective morphism with Y affine and let \mathcal{L} be an f -ample line bundle on X . Then:*

- (a) Given a global section $s \in \Gamma(X, \mathcal{L})$, let $X_s \subseteq X$ be the open subset where s is nonvanishing. Then X_s is an affine open subset of X .
- (b) There is an integer k_0 such that $\mathcal{L}^{\otimes k}$ is generated by global sections for all $k \geq k_0$.

Proof. This is proved in [73, (5.5.7)]. \square

Bibliography

- [1] O. Aichholzer, *Extremal properties of 0/1-polytopes of dimension 5*, in *Polytopes – Combinatorics and Computation*, (G. Kalai and G. Ziegler, eds.), DMV Seminar **29**, Birkhäuser, Boston, 2000, 111–130.
- [2] M. Atiyah, *On analytic surfaces with double points*, Proc. Roy. Soc. London Ser. A **247** (1958) 237244.
- [3] M. Atiyah and I. G. MacDonald, *Introduction to Commutative Algebra*, Addison-Wesley, Reading, MA, 1969.
- [4] M. Barile, *On simplicial toric varieties of codimension 2*, Rend. Istit. Mat. Univ. Trieste **39** (2007), 9–42
- [5] V. Batyrev, *Dual polyhedra and mirror symmetry for Calabi-Yau hypersurfaces in toric varieties*, J. Algebraic Geom. **3** (1994), 493–535.
- [6] V. Batyrev, *On the classification of smooth projective toric varieties*, Tohoku Math. J. **43** (1991), 569–585.
- [7] V. Batyrev, *On the classification of toric Fano 4-folds*, J. Math. Sci. (New York) **94** (1999), 1021–1050.
- [8] V. Batyrev, *Variations of the mixed Hodge structure of affine hypersurfaces in algebraic tori*, Duke Math. J. **69** (1993), 349–409.
- [9] V. Batyrev and D. Cox, *On the Hodge structure of projective hypersurfaces in toric varieties*, Duke Math. J. **75** (1994), 293–338.
- [10] V. Batyrev and L. Borisov, *On Calabi-Yau complete intersections in toric varieties*, in *Higher-dimensional complex varieties (Trento, 1994)*, (M. Andreatta and T. Peternell, eds.), de Gruyter, Berlin, 1996, 39–65.
- [11] M. Beck and S. Robins, *Computing the continuous discretely*, Springer, New York, 2007.
- [12] A. A. Beilinson, J. Bernstein and P. Deligne, *Faisceaux pervers*, in *Analysis and topology on singular spaces, I (Luminy, 1981)*, Astrisque **100** (1982) 5–171.
- [13] E. Bierstone and P. Milman, *Desingularization of toric and binomial varieties*, J. Algebraic Geom. **15** (2006), 443–486.
- [14] C. Birkar, *Birational Geometry*, lecture notes for a course taught at Cambridge University, Winter, 2007. Available electronically at arXiv:0706.1794 [math.AG].

- [15] R. Blanco and S. Encinas, *Embedded desingularization of toric varieties*, preprint, 2009. Available electronically at arXiv:0901.2211 [math.AG].
- [16] M. Blickle, *Multiplier ideals and modules on toric varieties*, Math. Z. **248** (2004), 113–121.
- [17] M. Blickle and R. Lazarsfeld, *An informal introduction to multiplier ideals*, in *Trends in Commutative Algebra*, (L. Avramov, M. Green and C. Huneke, eds.), Math. Sci. Res. Inst. Publ. **51**, Cambridge Univ. Press, Cambridge, 2004, 87–114.
- [18] A. Borel, et al., *Seminar on transformation groups*, Annals of Math. Studies **46**, Princeton Univ. Press, Princeton, 1960.
- [19] R. Bott, *Homogeneous vectors bundles*, Ann. Math. **66** (1957), 203–248.
- [20] T. Braden, *Remarks on the combinatorial intersection cohomology of fans*, Pure Appl. Math. Q. **2** (2006), 1149–1186.
- [21] G. Bredon, *Sheaf Theory*, second edition, Springer, New York, 1997.
- [22] M. Brion, *Piecewise polynomial functions, convex polytopes and enumerative geometry*, in *Parameter spaces (Warsaw, 1994)*, Banach Center Publ. **36**, Polish Acad. Sci., Warsaw, 1996, 25–44.
- [23] M. Brion, *Rational smoothness and fixed points of torus actions*, Transform. Groups **4** (1999), 127–156.
- [24] A. Brønsted, *An Introduction to Convex Polytopes*, Springer, 1983.
- [25] W. Bruns and J. Gubeladze, *Polytopal linear groups*, J. Algebra **218** (1999), 715–737.
- [26] W. Bruns and J. Gubeladze, *Semigroup algebras and discrete geometry*, in *Geometry of toric varieties*, (L. Bonavero and M. Brion, eds.), Sémin. Congr. **6**, Soc. Math. France, Paris, 2002, 43–127.
- [27] W. Bruns and B. Ichim, *NORMALIZ: Computing normalizations of affine semigroups*, with contributions by C. Söger, available electronically at www.math.uos.de/normaliz/, 2009.
- [28] W. Bruns, J. Gubeladze and N. V. Trung, *Normal polytopes, triangulations, and Koszul algebras*, J. Reine Angew. Math. **485** (1997), 123–160.
- [29] W. Bruns and J. Herzog, *Cohen-Macaulay Rings*, Cambridge Univ. Press, Cambridge, 1993.
- [30] A. Buch, J. F. Thomsen, N. Lauritzen and V. Mehta, *The Frobenius morphism on a toric variety*, Tohoku Math. J. **49** (1997), 355–366.
- [31] E. Cattani, D. Cox and A. Dickenstein, *Residues in toric varieties*, Compositio Math. **108** (1997), 35–76.
- [32] Y. Chen and V. Shokurov, *Strong rational connectedness of toric varieties*, preprint, 2009. Available electronically at arXiv:0905.1430 [math.AG].
- [33] D. Cox, *The homogeneous coordinate ring of a toric variety*, J. Algebraic Geom. **4** (1995), 15–50.
- [34] D. Cox and S. Katz, *Mirror Symmetry and Algebraic Geometry*, Amer. Math. Soc., Providence, RI, 1999.
- [35] D. Cox, J. Little and D. O’Shea, *Ideals, Varieties and Algorithms*, third edition, Undergraduate Texts in Math., Springer, New York, 2007.
- [36] D. Cox, J. Little and D. O’Shea, *Using Algebraic Geometry*, second edition, Graduate Texts in Math. **185**, Springer, New York, 2005.
- [37] D. Cox and C. von Renesse, *Primitive collections and toric varieties*, Tohoku Math. J. **61** (2009), 309–332.
- [38] D. Dais, *Geometric combinatorics in the study of compact toric surfaces*, in *Algebraic and Geometric Combinatorics*, (C. Athanasiadis, V. Batyrev, D. Dais, M. Henk and F. Santos, eds.), Contemp. Math. **423**, Amer. Math. Soc., Providence, RI, 2006, 71–123.

- [39] D. Dais, *Resolving 3-dimensional toric singularities*, in *Geometry of toric varieties*, (L. Bonavero and M. Brion, eds.), Sémin. Congr. **6**, Soc. Math. France, Paris, 2002, 213–225
- [40] D. Dais, U.-U. Haus and M. Henk, *On crepant resolutions of 2-parameter series of Gorenstein cyclic quotient singularities*, Results Math. **33** (1998), 208–265.
- [41] V. Danilov, *The geometry of toric varieties*, Russian Math. Surveys **33** (1978), 97–154; Uspekhi Mat. Nauk. **33** (1978), 85–134.
- [42] V. Danilov and A. Khovanskii, *Newton polyhedra and an algorithm for calculating Hodge-Deligne numbers* (Russian), Izv. Akad. Nauk SSSR Ser. Mat. **50** (1986), 925–945. English translation Math. USSR-Izv. **29** (1987), 279–298.
- [43] D. Delzant, *Hamiltoniens périodiques et images convexes de l'application moment*, Bull. Soc. Math. France **116** (1988), 315–339.
- [44] M. Demazure, *Sous-groupes algébriques de rang maximum du groupe de Cremona*, Ann. Sci. École Norm. Sup. **3** (1970), 507–588.
- [45] I. Dolgachev, *Lectures on Invariant Theory*, Cambridge Univ. Press, Cambridge, 2003.
- [46] A. Durfee, *Fifteen characterizations of rational double points and simple critical points*, Enseign. Math. **25** (1979), 131–163.
- [47] D. Eisenbud, *Commutative Algebra with a View Toward Algebraic Geometry*, Graduate Texts in Math. **150**, Springer, New York, 1995.
- [48] D. Eisenbud and J. Harris, *The Geometry of Schemes*, Graduate Texts in Math. **197**, Springer, New York, 2000.
- [49] D. Eisenbud, M. Mustață, Mircea and M. Stillman, *Cohomology on toric varieties and local cohomology with monomial supports*, J. Symbolic Comput. **29** (2000), 583–600.
- [50] G. Ewald, *Combinatorial Convexity and Algebraic Geometry*, Graduate Texts in Math. **168**, Springer, New York, 1996.
- [51] G. Ewald and U. Wessels, *On the ampleness of invertible sheaves in complete projective varieties*, Results Math. **19** (1991), 275–278.
- [52] E. M. Feichtner, *Rational versus real cohomology algebras of low-dimensional toric varieties*, Proc. Amer. Math. Soc. **131** (2003), 1695–1704.
- [53] O. Fujino, *Multiplication maps and vanishing theorems for toric varieties*, Math. Z. **257** (2007), 631–641.
- [54] O. Fujino, *Notes on toric varieties from Mori theoretic viewpoint*, Tohoku Math. J. **55** (2003), 551–564.
- [55] O. Fujino, *On the Kleiman-Mori cone*, Proc. Japan Acad. Ser. A Math. Sci. **81** (2005), 80–84.
- [56] O. Fujino, *Three-dimensional terminal toric flips*, Cent. Eur. J. Math. **7** (2009), 46–53.
- [57] O. Fujino, *Vanishing theorems for toric polyhedra*, preprint, 2007. Available electronically at arXiv:0707.3178 [math.AG].
- [58] W. Fulton, *Introduction to Toric Varieties*, Annals of Math. Studies **131**, Princeton Univ. Press, Princeton, NJ, 1993.
- [59] W. Fulton, *Intersection theory*, second edition, Ergebnisse der Mathematik und ihrer Grenzgebiete, 3. Folge, Band 2, Springer, Berlin, 1998.
- [60] W. Fulton, *Equivariant Cohomology in Algebraic Geometry*, Eilenberg lectures, Columbia University, Spring 2007, notes by D. Anderson. Available electronically at www.math.lsa.umich.edu/~dandersn/eilenberg.
- [61] W. Fulton and R. Lazarsfeld, *Connectivity and its applications in algebraic geometry*, in *Algebraic Geometry: Proceedings University of Illinois at Chicago Circle, 1980*, (A. Libgober and P. Wagreich, eds), Lecture Notes in Math. **862**, Springer, Berlin, 1981, 26–92.

- [62] I. M. Gelfand, M. M. Kapranov and A. V. Zelevinsky, *Discriminants, Resultants and Multidimensional Determinants*, Birkhäuser, Boston, 1994.
- [63] R. Godement, *Théorie des Faisceaux*, Hermann, Paris, 1964.
- [64] P. González Pérez and B. Teissier, *Embedded resolutions of non necessarily normal affine toric varieties*, C. R. Math. Acad. Sci. Paris **334** (2002), 379–382.
- [65] M. Goresky, R. Kottwitz and R. MacPherson, *Equivariant cohomology, Koszul duality, and the localization theorem*, Invent. Math. **131** (1998), 25–83.
- [66] M. Goresky and R. MacPherson, *Intersection homology theory*, Topology **19** (1980), 135–162.
- [67] M. Goresky and R. MacPherson, *Intersection homology theory II*, Invent. Math. **72** (1983), 77–129.
- [68] R. Goward, *A simple algorithm for principalization of monomial ideals*, Trans. Amer. Math. Soc. **357** (2005), 4805–4812.
- [69] H. Grauert and R. Remmert, *Coherent Analytic Sheaves*, Grundlehren der mathematischen Wissenschaften **265**, Springer, Berlin, 1984.
- [70] M. Greenberg and J. Harper, *Algebraic Topology: A First Course*, Benjamin/Cummings, Reading, MA, 1981. Reprinted by Westview Press, Boulder, CO.
- [71] P. Griffiths and J. Harris, *Principles of Algebraic Geometry*, Wiley, New York, 1978.
- [72] A. Grothendieck, *Revêtements étales et groupe fondamental (SGA I)*, Séminaire de géométrie algébrique du Bois Marie 1960–61 (with two papers by M. Raynaud), Lecture Notes in Math. **224**, Springer, Berlin, 1971. Updated and annotated reprint, Documents Mathématiques (Paris) **3**, Société Mathématique de France, Paris, 2003.
- [73] A. Grothendieck, *Éléments de géométrie algébrique (rédigés avec la collaboration de Jean Dieudonné), II. Étude globale élémentaire de quelques classes de morphismes*, Inst. Hautes études Sci. Publ. Math. **8** (1961), 5–222.
- [74] B. Grünbaum, *Convex Polytopes*, Wiley Interscience, New York, 1967. Second edition prepared by V. Kaibel, V. Klee and G. Ziegler, Springer, 2003.
- [75] C. Haase and I. Melnikov, *The reflexive dimension of a lattice polytope*, Ann. Comb. **10** (2006), 211–217.
- [76] J. Harris, *Algebraic Geometry: A First Course*, Graduate Texts in Math. **133**, Springer, New York, 1992.
- [77] R. Hartshorne, *Algebraic Geometry*, Graduate Texts in Math. **52**, Springer, New York, 1977.
- [78] R. Hartshorne, *Stable reflexive sheaves*, Math. Ann. **254** (1980), 121–176.
- [79] B. Hassett, *Introduction to Algebraic Geometry*, Cambridge Univ. Press, Cambridge, 2007.
- [80] A. Hatcher, *Algebraic Topology*, Cambridge Univ. Press, Cambridge, 2002.
- [81] H. Hauser, *The Hironaka Theorem on resolution of singularities (Or: a proof that we always wanted to understand)*, Bull. Amer. Math. Soc. **40** (2003), 323–403.
- [82] D. Hensley, *Continued Fractions*, World Scientific, Singapore, 2006.
- [83] R. Hemmecke, R. Hemmecke and P. Malkin, *4ti2 Version 1.2—Computation of Hilbert bases, Graver bases, toric Gröbner bases, and more*, available electronically at www.4ti2.de, 2005.
- [84] M. Hering, A. Küronya and S. Payne, *Asymptotic cohomological functions of toric divisors*, Adv. Math. **207** (2006), 634–645.
- [85] L. Hille and M. Perling, *A counterexample to King’s conjecture*, Compos. Math. **142** (2006), 1507–1521.
- [86] H. Hironaka, *Resolution of singularities of an algebraic variety over a field of characteristic zero I-II*, Ann. Math. **79** (1964), 109–326.

- [87] F. Hirzebruch, *Hilbert Modular Surfaces*, *Ens. Math.* **19** (1973), 183–281.
- [88] M. Hochster, *Rings of invariants of tori, Cohen-Macaulay rings generated by monomials, and polytopes*, *Ann. Math.* **96** (1972), 318–337.
- [89] J. Howald, *Multiplier ideals of monomial ideals*, *Trans. Amer. Math. Soc.* **353** (2001), 2665–2671.
- [90] S. Hu, *Semistable degeneration of toric varieties and their hypersurfaces*, *Comm. Anal. Geom.* **14** (2006), 59–89.
- [91] K. Hulek, *Elementary Algebraic Geometry*, Amer. Math. Soc., Providence, RI, 2003.
- [92] J. Humphreys, *Linear Algebraic Groups*, Springer, Graduate Texts in Math. **21**, New York, 1975.
- [93] N. Ilten, *Deformations of smooth toric surfaces*, preprint, 2009. Available electronically at arXiv:0902.0529 [math.AG].
- [94] Y. Ito, *Minimal resolution via Gröbner basis*, in *Algebraic Geometry in East Asia*, (A. Ohbuchi, K. Konno, S. Usui, A. Moriwaki and N. Nakayama, eds.), World Sci. Publ., River Edge, NJ, 2002, 165–174.
- [95] Y. Ito, *Special McKay Correspondence*, in *Geometry of toric varieties*, (L. Bonavero and M. Brion, eds.), Sémin. Congr. **6**, Soc. Math. France, Paris, 2002, 213–225.
- [96] S. Iyengar, G. Leuschke, A. Leykin, C. Miller, E. Miller, A. Singh and U. Walther, *Twenty-four Hours of Local Cohomology*, *Grad. Stud. Math.* **87**, Amer. Math. Soc., Providence, RI, 2007.
- [97] N. Jacobson, *Basic Algebra II*, Freeman, San Francisco, 1980.
- [98] K. Jaczewski, *Generalized Euler sequences and toric varieties*, in *Classification of Algebraic Varieties (L'Aquila, 1992)*, (C. Ciliberto, E. L. Livorni and A. Sommese, eds.), *Contemp. Math.* **162**, Amer. Math. Soc., Providence, RI, 1994, 227–247.
- [99] A. Jordan, *Homology and Cohomology of Toric Varieties*, Ph.D. thesis, University of Konstanz, 1998. Available electronically at kops.ub.uni-konstanz.de/volltexte/2006/2037/pdf/preprint_057.pdf.
- [100] A. Kasprzyk, M. Kreuzer and B. Nill, *On the combinatorial classification of toric log del Pezzo surfaces*, preprint, 2008. Available electronically at arXiv:0810.2207 [math.AG].
- [101] A. Katsabekis and A. Thoma, *Toric sets and orbits on toric varieties*, *J. Pure Appl. Algebra* **181** (2003), 75–83.
- [102] K. Kaveh, *Note on the cohomology ring of spherical varieties and volume polynomial*, preprint, 2003. Available electronically at arXiv:math.AG/0312503.
- [103] G. Kempf, F. Knudsen, D. Mumford and B. Saint-Donat, *Toroidal Embeddings I*, *Lecture Notes in Math.* **339**, Springer, New York, 1973.
- [104] S. Kleiman, *Toward a numerical theory of ampleness*, *Ann. of Math.* **84** (1966), 293–344.
- [105] P. Kleinschmidt, *A classification of toric varieties with few generators*, *Aequationes Math.* **35** (1988), 254–266.
- [106] A. Klyachko, *Equivariant vector bundles over toric varieties*, *Math. USSR-Izv.* **35** (1990), 337–375.
- [107] J. Kollár and S. Mori, *Birational Geometry of Algebraic Varieties*, Cambridge Univ. Press, Cambridge, 1998.
- [108] S. Krantz, *Geometric Function Theory: Explorations in Complex Analysis*, Birkhäuser, Boston, 2005.
- [109] A. Kresch, *Gromov-Witten invariants of a class of toric varieties*, *Michigan Math. J.* **48** (2000), 369–391.

- [110] M. Kreuzer and H. Skarke, *PALP: A package for analyzing lattice polytopes with applications to toric geometry*, *Comput. Phys. Comm.* **157** (2004), 87–106.
- [111] E. Kunz (with contributions by D. Cox and A. Dickenstein), *Residues and Duality for Projective Algebraic Varieties*, Amer. Math. Soc., Providence, RI, 2008.
- [112] R. Laterveer, *Linear systems on toric varieties*, *Tohoku Math. J.* **48** (1996), 451–458.
- [113] R. Lazarsfeld, *Positivity in Algebraic Geometry*, Vols. I and II, Springer, New York, 2004.
- [114] Y. Liu, L. E. Trotter and G. Ziegler, *On the height of the minimal Hilbert basis*, *Results Math.* **23** (1993), 374–376.
- [115] P. Mani, *Spheres with few vertices*, *Journal of Comb. Theory Ser. A* **13** (1992), 346–352.
- [116] E. Materov, *The Bott formula for toric varieties*, *Mosc. Math. J.* **2** (2002), 161–182, 200.
- [117] K. Matsuki, *Introduction to the Mori Program*, Universitext, Springer, New York, 2002.
- [118] H. Matsumura, *Commutative Ring Theory*, Cambridge Univ. Press, Cambridge, 1986.
- [119] A. Mavlyutov, *Cohomology of rational forms and a vanishing theorem on toric varieties*, *J. Reine Angew. Math.* **615** (2008), 45–58.
- [120] A. Mavlyutov, *Semiample hypersurfaces in toric varieties* *Duke Math. J.* **101** (2000), 85–116.
- [121] J. McCleary, *A User's Guide to Spectral Sequences*, Cambridge Univ. Press, Cambridge, 2001.
- [122] M. McConnell, *The rational homology of toric varieties is not a combinatorial invariant*, *Proc. Amer. Math. Soc.* **104** (1989), 986–991.
- [123] E. Miller and B. Sturmfels, *Combinatorial Commutative Algebra*, Graduate Texts in Math. **227**, Springer, New York, 2005.
- [124] T. Morita, *Hilbert schemes of finite abelian group orbits and Gröbner fans*, preprint, 2007. Available electronically at arXiv:0712.2892 [math.AG].
- [125] D. Mumford, *Algebraic Geometry I: Complex Projective Varieties*, Springer, Berlin, 1976.
- [126] D. Mumford, *The Red Book of Varieties and Schemes*, second expanded edition, *Lecture Notes in Math.* **1358**, Springer, Berlin, 1999.
- [127] D. Mumford, J. Fogarty, J. and F. Kirwan, *Geometric Invariant Theory*, third edition, *Ergebnisse der Mathematik und ihrer Grenzgebiete* **34**, Springer, Berlin, 1994.
- [128] J. Munkres, *Elements of Algebraic Topology*, Addison-Wesley, Reading, MA, 1984. Reprinted by Westview Press, Boulder, CO.
- [129] M. Mustață, *Local cohomology at monomial ideals*, *J. Symbolic Comput.* **29** (2000), 709–720.
- [130] M. Mustață, *Vanishing theorems on toric varieties*, *Tohoku Math. J.* **54** (2002), 451–470.
- [131] B. Nill, *Gorenstein toric Fano varieties*, *Manuscr. Math.* **116** (2005), 183–210.
- [132] B. Nill, *Volume and lattice points of reflexive simplices*, *Discr. Comp. Geom.* **37** (2007), 301–320.
- [133] M. Øbro, *An algorithm for the classification of smooth Fano polytopes*, preprint, 2007. Available electronically at arXiv:0704.0049 [math.CO].
- [134] T. Oda, *Convex Bodies and Algebraic Geometry*, Springer, New York, 1988.
- [135] T. Oda, *Torus Embeddings and Applications. Based on joint work with Katsuya Miyake*, Tata Institute of Fundamental Research, Bombay; Springer, Berlin, 1978.
- [136] T. Oda, *Simple convex polytopes and the strong Lefschetz theorem*, *J. Pure Appl. Algebra* **71** (1991), 265–286.
- [137] S. Ogata and K. Nakagawa, *On generators of ideals defining projective toric varieties*, *manuscripta math.* **108** (2002), 33–42.
- [138] S. Payne, *Moduli of toric vector bundles*, preprint, 2008. Available electronically at arXiv:0705.0410 [math.AG].

- [139] S. Payne, *Equivariant Chow cohomology of toric varieties*, Math. Res. Lett. **13** (2006), 29–41.
- [140] M. Perling, *Divisorial cohomology vanishing on toric varieties*, preprint, 2009, to appear.
- [141] C. Peters and J. Steenbrink, *Mixed Hodge Structures*, Springer, New York, 2008.
- [142] B. Poonen and F. Rodriguez-Villegas, *Lattice polygons and the number 12*, Am. Math. Monthly **107** (2000), 238–250.
- [143] A. V. Pukhlikov and A. G. Khovanskii, *The Riemann-Roch theorem for integrals and sums of quasipolynomials on virtual polyhedra*, Algebra i Analiz **4** (1992), 188–216, translation in St. Petersburg Math J. **4** (1993), 789–812.
- [144] M. Reid, *Canonical 3-folds*, in *Journées de Géométrie Algébrique d'Angers, Juillet 1979/Algebraic Geometry, Angers, 1979*, (A. Beauville, ed.), Sijthoff & Noordhoff, Alphen aan den Rijn, 1980, 273–310.
- [145] M. Reid, *Decomposition of Toric Morphisms*, in *Arithmetic and Geometry*, (M. Artin and J. Tate, eds.), Birkhäuser, Boston Basel Berlin, 1983, 395–418.
- [146] M. Reid, *Undergraduate Algebraic Geometry*, Cambridge Univ. Press, Cambridge, 1989.
- [147] E. Reyes, R. Villarreal and L. Zárate, *A note on affine toric varieties*, Linear Algebra Appl. **318** (2000), 173–179.
- [148] J. Richter-Gebert, B. Sturmfels and T. Theobald, *First steps in tropical geometry*, in *Idempotent Mathematics and Mathematical Physics*, (G. Litvinov and V. Maslov, eds.), Contemp. Math. **377**, Amer. Math. Soc., Providence, RI, 2003.
- [149] R. T. Rockafellar, *Convex Analysis*, Princeton Univ. Press, Princeton, NJ, 1970.
- [150] J. J. Rotman, *Advanced Modern Algebra*, Prentice-Hall, Upper Saddle River, NJ, 2002.
- [151] H. Sato, *Toward the classification of higher-dimensional toric Fano varieties*, Tohoku Math. J. **52** (2000), 383–413.
- [152] I. Shafarevich, *Basic Algebraic Geometry*, Volumes 1 and 2, Springer, New York, 1994 and 1996.
- [153] H. Schenck, *Computational Algebraic Geometry*, Cambridge Univ. Press, Cambridge, 2003.
- [154] J.-P. Serre, *Faisceaux algébriques cohérents*, Ann. Math. **61**, (1955), 197–278.
- [155] J.-P. Serre, *Géométrie algébrique et géométrie analytique*, Ann. Inst. Fourier (Grenoble) **6** (1956), 1–42.
- [156] A. Simis, W. Vasconcelos and R. Villarreal, *On the ideal theory of graphs*, J. Algebra **167** (1994), 389–416.
- [157] N. J. A. Sloane, *On-line Encyclopedia of Integers Sequences*, 2006. Published electronically at the web site www.research.att.com/~njas/sequences/.
- [158] K. Smith, L. Kahanpää, P. Kekäläinen and W. Traves, *An Invitation to Algebraic Geometry*, Springer, New York, 2000.
- [159] F. Sottile, *Toric ideals, real toric varieties, and the algebraic moment map*, in *Topics in Algebraic Geometry and Geometric Modeling (Proceedings of AGGM, Vilnius, Lithuania.)*, (R. Goldman and R. Krasuaskas eds), Contemp. Math. **334**, Amer. Math. Soc., Providence, RI, 2003, 225–240. Corrected version available electronically at arXiv:math.AG/0212044.
- [160] E. Spanier, *Algebraic Topology*, McGraw-Hill, New York, 1966. Reprinted by Springer Verlag, New York, 1994.
- [161] R. Stanley, *Generalized H-vectors, intersection cohomology of toric varieties, and related results*, in *Commutative algebra and combinatorics (Kyoto 1985)*, (M. Nagata and H. Matsumura, eds.), Adv. Stud. Pure Math. **11**, North-Holland, Amsterdam, 1987, 187–213.
- [162] H. Stark, *An Introduction to Number Theory*, MIT Press, Cambridge, MA, 1978.

-
- [163] J. Steenbrink, *Intersection form for quasi-homogeneous singularities*, *Compositio Math.* **34** (1977), 211–223.
- [164] J. Steenbrink, *Mixed Hodge structure on the vanishing cohomology*, in *Real and complex singularities (Proc. Ninth Nordic Summer School/NAVF Sympos. Math., Oslo, 1976)*, Sijthoff and Noordhoff, Alphen aan den Rijn, 1977, 525–563.
- [165] R. S. Strichartz, *The Way of Analysis*, Jones and Bartlett, Boston, MA, 1995.
- [166] B. Sturmfels, *Gröbner Bases and Convex Polytopes*, Amer. Math. Soc., Providence, RI, 1996.
- [167] H. Sumihiro, *Equivariant completion, I, II*, *J. Math. Kyoto Univ.* **14** (1974), 1–28; **15** (1975), 573–605.
- [168] I. Swanson and C. Huneke, *Integral Closure of Ideals, Rings, and Modules*, LMS Lecture Note Series **336**, Cambridge Univ. Press, Cambridge, 2006.
- [169] B. Tesser, *Monomial ideals, binomial ideals, polynomial ideals*, in *Trends in Commutative Algebra*, (L. Avramov, M. Green and C. Huneke, eds.), Math. Sci. Res. Inst. Publ. **51**, Cambridge Univ. Press, Cambridge, 2004, 211–246.
- [170] H. Thompson, *Comments on toric varieties*, preprint, 2003. Available electronically at arXiv:math.AG/0310336.
- [171] K. Ueno, *Algebraic Geometry 2*, Amer. Math. Soc., Providence, RI, 2001.
- [172] R. Villarreal, *Monomial Algebras*, Marcel Dekker, Inc., New York, 2001.
- [173] C. Weibel, *An Introduction to Homological Algebra*, Cambridge Univ. Press, Cambridge, 1994.
- [174] O. Zariski and P. Samuel, *Commutative Algebra*, Volume II, Van Nostrand, Princeton, 1960. Corrected reprint, Springer, 1976.
- [175] G. Ziegler, *Lectures on Polytopes*, Graduate Texts in Math. **152**, Springer, 1995.

Index

- absolutely ample, 336
- abstract variety, 97, 99
- affine
 - piece of a variety, 51, 52
 - scheme, 4, 104
 - toric variety, 12, 18
 - of a cone, 30
 - variety, 3
- affine cone
 - of a projective toric variety, 56
 - of a projective variety, 50
- affine hyperplane, 63
- affine semigroup, 16
- algebraic action, 12, 106
- ample, *see* Cartier divisor, ample
 - absolutely, 336
 - relatively with respect to f , 337

- basepoint free, *see also* sheaf, generated by global sections
 - Cartier divisor, *see* Cartier divisor, basepoint free
 - subspace of global sections, 255
- basic simplex, 68
- binomial, 16
- Birkhoff polytope, 64
- blowup, 98, 105, 111, 130, 131, 172, 174, 186, 188, 278, 310

- cancellative semigroup, 22
- Carathéodory's theorem, 69
- Cartier data, 179, 191
- Cartier divisor, 158
 - ample, 260, 262, 269, 296
 - basepoint free, 256, 260, 262, 266, 283, 319
 - f -ample, 322
 - f -very ample, 322
 - local data of, 158
 - nef, 283, 296
 - numerical equivalence of, 284
 - numerically equivalent to zero, 284
 - of a polyhedron, 313
 - of a polytope, 180
 - on an irreducible variety, 255
 - torus-invariant, *see* torus-invariant, Cartier divisor
 - very ample, 260, 262
- character, 11
- Chevalley's Theorem, 143
- class group, 159
- classical topology, 4, 50, 102, 113, 139, 146
- closed half-space, 25, 63
- codimension of a prime ideal, 155
- coherent sheaf, 164
- combinatorially equivalent polytopes, 65
- compact, 113, 139, 146
- compatibility conditions, 97, 250
- compatible map of lattices, 125
- complete fan, 113, 139, 146, 191
- complete linear system, 259
- complete variety, 141, 146
- cone
 - convex polyhedral, *see* polyhedral cone
 - of a polyhedron, 335
 - of a polyhedron, 310
 - of a polytope, 24, 69, 86
 - polyhedral, *see* polyhedral cone
 - rational polyhedral, *see* rational polyhedral cone
 - simplicial, *see* simplicial cone
 - smooth, *see* smooth cone
 - strongly convex, *see* strongly convex cone
- constructible set, 123

- convex
 - function, 265
 - hull, 24
 - polyhedral cone, *see* polyhedral cone
- convex support of full dimension, 318
- coordinate ring, 3, 4
- degenerate fan, 276
- degree
 - of a divisor on a curve, 280
 - of a line bundle on a curve, 280
- determinantal variety, 13
- diagonal map, 102
- dimension at a point, 6, 101
- dimension of a cone, 24
- dimension of a polytope, 63
- dimension of a ring, 154
- direct image, 164
- direct limit, 100, 243
- directed set, 180, 243
- directed system, 243
- discrete valuation, 153
- discrete valuation ring (DVR), 153
- distinguished point, 116, 118, 130, 135
- divisor
 - Cartier, *see* Cartier divisor
 - linear equivalence of, 158
 - locally principal, *see* locally principal divisor
 - nef, *see* Cartier divisor, nef
 - numerically effective, *see* Cartier divisor, nef
 - of a character, 169
 - of a rational function, 157
 - of poles, 158
 - of zeros, 158
 - principal, 157
 - Weil, *see* Weil divisor
- doubly-stochastic matrix, 64
- dual cone, 24
- dual face, 26
- dual polytope, 65
- dual sheaf, 253
- edge, 25, 63
- effective divisor, 157
- equivariant map, 41, 126
- exact sequence of sheaves, 246
- extremal wall, *see* wall, extremal
- extremal ray, 287, 297
- extremal walls, 287
- f -ample, *see* Cartier divisor, f -ample
- f -very ample, *see* Cartier divisor, f -very ample
- $4\mathbb{Z}$, 72
- face, 25, 63
- facet, 25, 63
 - normal, 26, 64
- presentation, 66
- fan, 77, 106
 - complete, *see* complete fan
 - normal, *see* normal fan
 - refinement of, *see* refinement of a fan
 - simplicial, *see* simplicial fan
 - smooth, *see* smooth fan
- fiber bundle, 133
- fiber product of varieties, 102
- Fibonacci number, 22
- finite quotient singularities, 113
- finitely generated semigroup, 16
- formal power series, 10
- fractional ideal, 168
- full dimensional
 - polytope, 64
- full dimensional
 - convex support, 318
 - polyhedron, 311
- function field, 100
- GAGA, 142, 143
- generated by global sections, *see* sheaf, generated
 - by global sections
- global sections, 187
 - of a sheaf, 164, 246
 - of a toric sheaf, 188, 191
 - of a vector bundle, 249
- gluing data, 97, 250
- Gordan's Lemma, 30
- graded module, 225, 246, 301
 - shift of, 225
- Grassmannian, 252, 258
- $\mathcal{H}om$ sheaf, 247, 253
- Hausdorff topological space, 102
- height of a prime ideal, 155
- Hilbert basis, 32, 33
- Hilbert Basis Theorem, 3
- Hirzebruch surface, 112, 173, 189, 261, 267, 271, 294, 328
- homogeneous coordinate ring, 49
- homogeneous coordinates, 49
- homogenization, 190
- homomorphism of sheaves, 164, 244
 - injective, 244
 - surjective, 244
- image sheaf, 245
- index of a simplicial cone, 291
- inner normal fan, *see* normal fan
- integral closure, 5
- integrally closed ring, 5
- intersection product, 281
 - on a toric variety, 282, 291
- inverse limit, 180
- inverse system, 180

- invertible sheaf, 166, 252, 253
 inward-pointing facet normal, *see* facet, normal
 irreducible components, 97
 irreducible variety, 97
 irrelevant ideal, 205
 isomorphism of varieties, 96
- Jacobian matrix, 7
- kernel sheaf, 245
 Kleinschmidt's classification theorem, 331
 Krull Principal Ideal Theorem, 159, 167
- lattice, 13
 lattice ideal, 16
 lattice polyhedron, 310
 lattice polytope, 66
 Laurent polynomial, 5
 limit of one-parameter subgroup, 115, 116, 139, 142, 146
 line bundle, 251, 253
 ample, 260
 f-ample, 322
 f-very ample, 322
 pullback of, 256
 very ample, 260
 linear equivalence, *see* divisor, linear equivalence of
 linearly equivalent divisors, 254
 local data, 158, 251, 255
 toric, 179
 local ring, 6, 154
 at a point, 6, 9, 94, 99
 at a prime divisor, 155
 localization, 5, 9
 homogeneous, 335
 locally principal divisor, 158
 locally trivial fiber bundle, 134
- maximal spectrum, 4
 minimal generator, 30
 Minkowski sum, 65, 190, 309
 Mori cone, 285
 of a toric variety, 286, 296
 morphism of varieties, 3, 95
 projective, *see* projective morphism
 proper, *see* proper morphism
 multiplicative subset, 9
 multiplicity of a simplicial cone, 291
- Nakayama's Lemma, 167
 nef cone, 285
 of a toric variety, 286
 nef divisor, *see* Cartier divisor, nef
 Newton polytope, 186
 nilpotents, 4, 8, 9, 48, 103, 105
 Noetherian, 154
- nonnormal toric variety, 149
 nonsingular point, 6
 normal
 affine toric variety, 37
 polyhedron, 314
 polytope, 67, 85
 toric variety, 85, 107
 variety, 5, 100
 normal fan
 of a polyhedron, 312
 of a polytope, 75, 77, 108, 274
 normal ring, 5, 154, 155
 normalization, 5, 150
 of a projective toric variety, 152
 of an affine toric variety, 39, 151
 of an irreducible curve, 280
 Nullstellensatz, 3
 numerically effective divisor, *see* Cartier divisor, nef
 numerically equivalent
 divisors, *see* Cartier divisor, numerical
 equivalence of
 proper 1-cycles, *see* proper 1-cycle, numerical
 equivalence of
 to zero, *see* Cartier divisor, numerically
 equivalent to zero *and* proper 1-cycle,
 numerically equivalent to zero
- one-parameter subgroup, 11
 orbifold, 46, 113
 orbit closure, 121, 135
 Orbit-Cone Correspondence, 119
 nonnormal case, 152
 order of vanishing, 156
- perfect field, 48
 permutation matrix, 55
 Picard group, 159, 254
 pointed affine semigroup, 36
 polar polytope, 65
 pole, 157
 polyhedral cone, 23
 polyhedron, 188, 309
 full dimensional, *see* full dimensional,
 polyhedron
 lattice, *see* lattice polyhedron
 normal, *see* normal, polyhedron
 of a torus-invariant divisor, 188, 266, 318
 very ample, *see* very ample, polyhedron
 polytope, 24, 63
 combinatorially equivalent, *see* combinatorially
 equivalent polytopes
 full dimensional, *see* full dimensional, polytope
 lattice, *see* lattice polytope
 normal, *see* normal, polytope
 simple, *see* simple polytope
 simplicial, *see* simplicial polytope

- smooth, *see* smooth polytope
- very ample, *see* very ample, polytope
- pre-variety, 102
- presheaf, 163, 245
- primary decomposition, 159
- prime divisor, 155
- primitive collection, 295, 329
- primitive relation, 296, 329
- principal divisor, *see* divisor, principal
- principal ideal domain (PID), 154, 155
- product variety, 7, 53, 101, 305
 - class group of, 173
 - toric, 47, 89, 111
- Proj, 313, 335
- projective bundle
 - of a coherent sheaf, 309
 - of a locally free sheaf, 308
 - of a vector bundle, 308
 - toric, 327
- projective morphism, 306, 307, 337, 338
- projective space, 49
- projective toric variety, 55
- projective variety, 49
- projective with respect to a line bundle, 306, 337
- projectively normal variety, 61, 85
- proper 1-cycle
 - numerical equivalence of, 285
- proper 1-cycle, 285
 - numerically equivalent to zero, 285
- proper continuous map, 140, 142
- proper face, 25
- proper morphism, 141, 142, 307
- Puiseux series, 186
- pullback, *see* line bundle, pullback of
- pullback of a torus-invariant Cartier divisor, 274
- \mathbb{Q} -Cartier divisor, 178
- \mathbb{Q} -factorial, 46
- quasicoherent sheaf, 164
- quasicompact, 104
- quasiprojective toric variety, 321
- quasiprojective variety, 305, 307
- rational normal cone, 50
- rational function, 51, 100
- rational normal cone, 13, 32, 38, 40, 46, 176
- rational normal curve, 50, 57
- rational normal scroll, 83, 112
- rational polyhedral cone, 29
- ray generator, 29
- real projective plane, 71
- recession cone, 310
- refinement of a fan, 130
- reflexive polytope, 80, 87
- reflexive sheaf, 166
- regular cone, *see* smooth cone
- regular fan, 113
- regular local ring, 7, 155
- regular map, 93, 98
- relative interior, 27
- relatively ample with respect to f , 337
- restriction of a divisor, 158
- ring of invariants, 44
- ringed space, 95, 99
- saturated affine semigroup, 37
- section
 - of a sheaf, 163
 - of a vector bundle, 249
- Segre embedding, 52
- self-intersection, 295
- semigroup, 16
- semigroup algebra, 17
 - of a cone, 30
- semigroup homomorphism, 35, 116
- separated variety, 102
- separating transcendence basis, 48
- Separation Lemma, 28, 107
- set-theoretic complete intersection, 22
- sheaf, 95
 - constant, 253
 - generated by global sections, 247, 256, 338
 - locally constant, 253
 - locally free, 248
 - of \mathcal{O}_X -modules, 163, 243
 - of a torus-invariant divisor, 187
 - of a graded module, 226, 246, 301
 - of a torus-invariant divisor
 - global sections of, 187, 188, 191
 - of sections of a vector bundle, 250
- sheafification, 245
- simple polytope, 64
- simplex, 64
- simplicial cone, 30
 - multiplicity of, 291
- simplicial fan, 113
- simplicial polytope, 64
- simplicial toric variety, 178
- singular point, 6
- singular locus, 161
 - of a normal variety, 161
- Smith normal form, 171
- smooth cone, 30, 40
- smooth fan, 113
- smooth point, 6, 101
- smooth polytope, 86
- smooth toric variety, 40, 86, 113, 177
- smooth variety, 6, 101
- span of a cone, 24
- Spec, 4, 335
- splitting fan, 133
- stalk of a sheaf, 244, 255
- standard n -simplex Δ_n , 66
- star subdivision, 130, 132

- strictly convex, *see* support function, of a Cartier divisor, strictly convex
- strongly convex cone, 28
- structure sheaf, 95, 99
- sublattice of finite index, 44
- subvariety, 97
- Sumihiro's Theorem, 108, 149
- support function, 181
 - integral with respect to a lattice, 181
 - of a Cartier divisor, 182, 264
 - convex, 265, 266, 319
 - strictly convex, 268, 269, 320–323
 - of a polytope, 184
- support of a divisor, 157
- support of a fan, 106, 113
- supporting affine hyperplane, 63
- supporting half-space, 25
- supporting hyperplane, 25
- Sylvester sequence, 92

- 2-neighborly polytope, 72
- tautological bundle, 252, 254, 258
- tensor product, 8, 48
 - of sheaves, 247, 253
- tent analogy, 264, 265, 268
- Toric Cone Theorem, 286, 287
- toric fibration, 134
- toric ideal, 16
- Toric Kleiman Criterion, 284
- toric morphism, 41, 42, 125, 135
 - projective, 321, 323
 - proper, 142
- toric set, 21
- toric variety, 106
 - affine, *see* affine, toric variety
 - normal, *see* normal, toric variety
 - of a fan, 107
 - of a polyhedron, 312
 - of a polytope, 82, 108
 - projective, *see* projective toric variety
 - quasiprojective, *see* quasiprojective toric variety
- torsion-free semigroup, 22
- torus, 5, 10
 - embedding, 108
 - of a projective toric variety, 58
 - of an affine toric variety, 13
 - orbit, 118
- torus-invariant
 - Cartier divisor, 174
 - prime divisor, 168
 - Weil divisor, 170, 173
- total coordinate ring, 246, 301
- transportation polytope, 64
- tropical polynomial, 186
- tropical variety, 186
- tropicalization, 186

- unique factorization domain (UFD), 7
- universally closed, 141

- valuative criterion for properness, 147
- variety
 - abstract, *see* abstract variety
 - affine, *see* affine, variety
 - complete, *see* complete variety
 - irreducible, *see* irreducible variety
 - normal, *see* normal, variety
 - projective, *see* projective variety
 - projectively normal, *see* projectively normal variety
 - quasiprojective, *see* quasiprojective variety
 - separated, *see* separated variety
 - toric, *see* toric variety
- vector bundle, 248
 - chart of, 248
 - decomposable, 326
 - fiber above a point, 248, 255
 - sheaf of sections of, 250
 - toric, 324, 326
 - transition functions of, 248, 250
 - trivialization of, 248
- vertex, 63
- very ample
 - divisor, *see* Cartier divisor, very ample
 - polyhedron, 314
 - polytope, 71, 75, 87, 262

- wall, 265, 292
 - extremal, 297
- wall relation, 293
- weighted homogeneous polynomial, 53
- weighted projective space, 53, 112, 174, 186
- Weil divisor, 157
 - torus-invariant, *see* torus-invariant, Weil divisor

- Zariski closure, 4
- Zariski tangent space, 101
- Zariski tangent space, 6
- Zariski topology, 4, 50, 97