We begin with a comment related to the example of a separable differential equation that we discussed last class.

Example. After separating variables on the differential equation

$$\frac{dy}{dt} = -2ty^2,$$

we obtained the family of solutions $y(t) = \frac{1}{t^2 + k}$ where k is an arbitrary constant.

For the initial condition $y(0) = \frac{1}{2}$ we have $k = 2$, and the solution is $y(t) = \frac{1}{t^2 + 2}$ with a domain of $-\infty < t < \infty$.

For the initial condition $y(0) = -\frac{1}{2}$ we have $k = -2$, and the solution is $y(t) = \frac{1}{t^2 - 2}$ with a domain of $-\sqrt{2} < t < \sqrt{2}$.

We turn to `FirstOrderExamples` to get a sense of the graphs of these solutions:

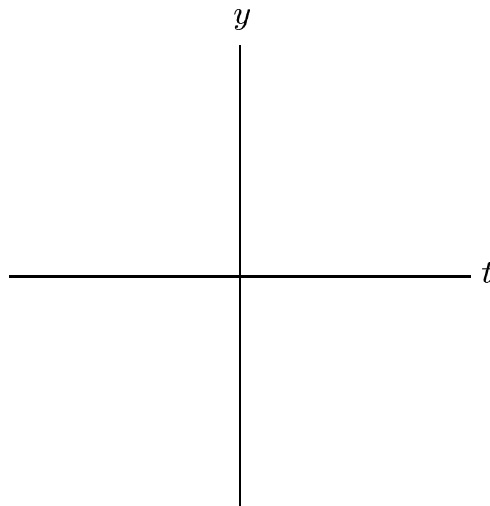

What's the general solution to $\frac{dy}{dt} = -2ty^2$? (Think before you answer.)

Slope fields

A **slope field** in the ty -plane is a picture of a first-order differential equation

$$\frac{dy}{dt} = f(t, y).$$

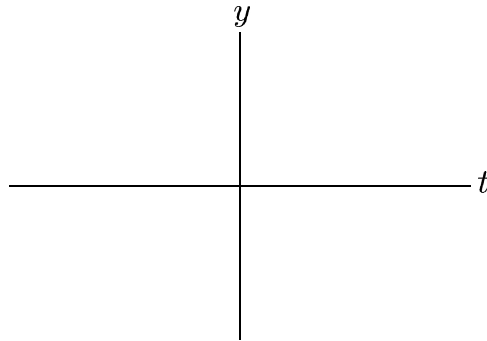

The graph of a solution must be everywhere tangent to the slope field.

Example. Consider the differential equation

$$\frac{dy}{dt} = -2ty^2$$

on which we separated variables.

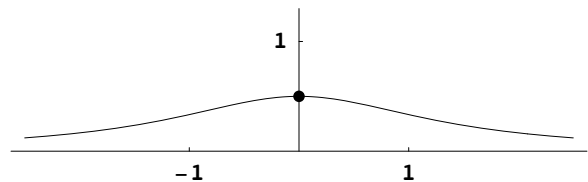

Example. Consider the differential equation

$$\frac{dy}{dt} = y - t.$$

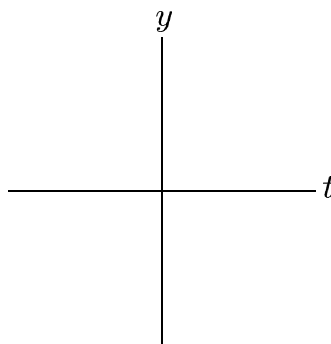

Using the computer to plot the slope field, we get

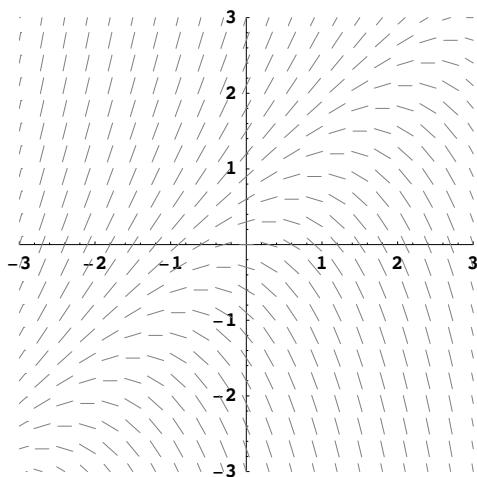

The TargetPractice tool is a fun way to see how the slope field relates to the solutions of the differential equation.

Important special cases:

1. $\frac{dy}{dt} = f(t)$

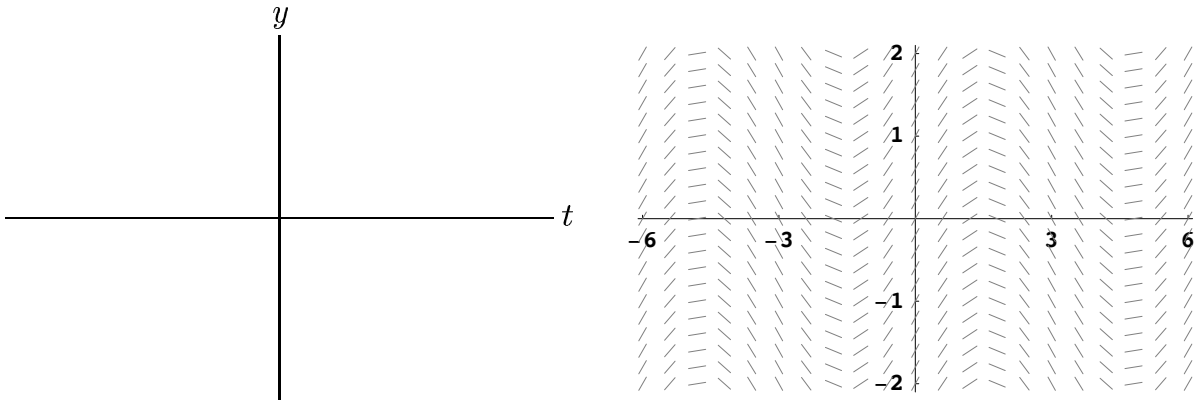

2. $\frac{dy}{dt} = f(y)$ (autonomous)

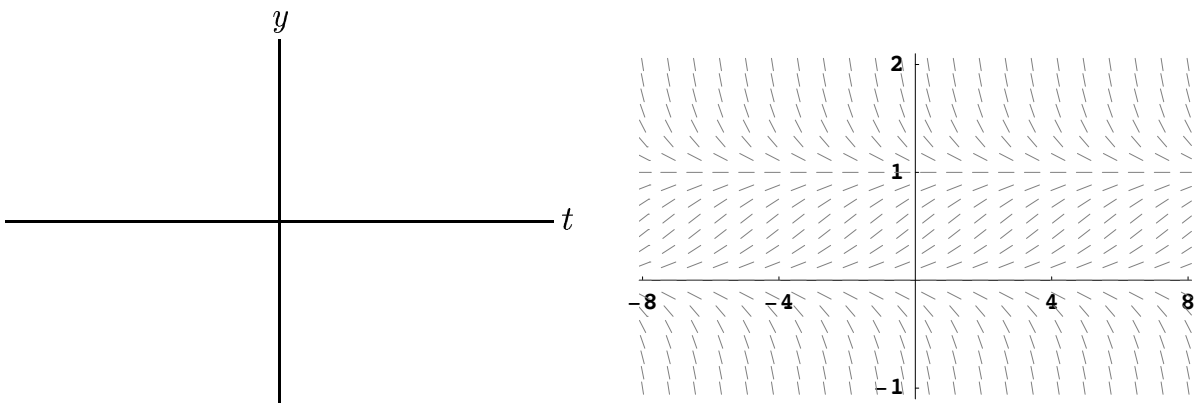

Consider the following 8 first-order equations:

- | | | | |
|------------------------------|---------------------------------|----------------------------|----------------------------|
| 1. $\frac{dy}{dt} = t - 1$ | 2. $\frac{dy}{dt} = t + 1$ | 3. $\frac{dy}{dt} = y + 1$ | 4. $\frac{dy}{dt} = 1 - y$ |
| 5. $\frac{dy}{dt} = y^2 + y$ | 6. $\frac{dy}{dt} = y(y^2 - 1)$ | 7. $\frac{dy}{dt} = y - t$ | 8. $\frac{dy}{dt} = y + t$ |

Four of the associated slope fields are shown below. Pair the slope fields with their associated equations. Provide a brief justification for your choice.

Slope Field A

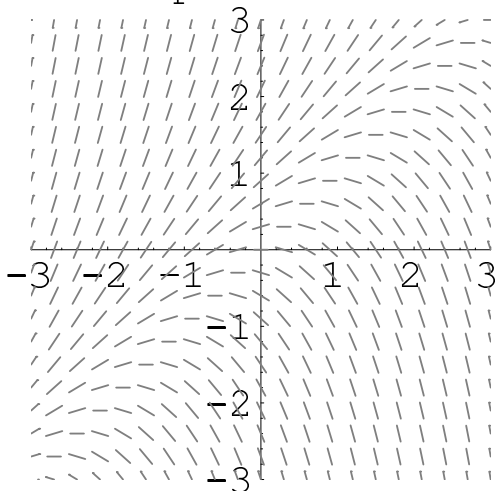

Slope Field B

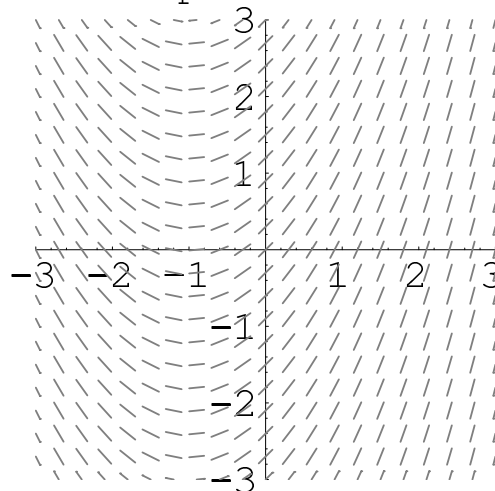

Slope Field C

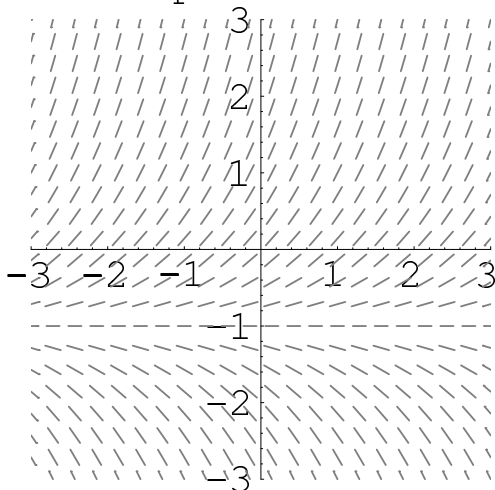

Slope Field D

